

# Modes of Heat Transfer

Theory at a Glance (For IES, GATE, PSU)

## Heat Transfer by Conduction

**Kinetic Energy of a molecule is the sum of**

- A. Translational Energy
- B. Rotational Energy
- And C. Vibrational Energy

**Increase in Internal Energy means**

- A. Increase in Kinetic Energy
- or B. Increase in Potential Energy
- or C. Increase in both Kinetic Energy and Potential Energy.

## Fourier's Law of Heat Conduction

$$Q = -kA \frac{dt}{dx}$$

The temperature gradient  $\left(\frac{dt}{dx}\right)$  is always negative along positive  $x$  direction and, therefore, the value as  $Q$  becomes + ve.

**Essential Features of Fourier's law:**

1. It is applicable to all matter (may be solid, liquid or gas).
2. It is a vector expression indicating that heat flow rate is in the direction of decreasing temperature and is normal to an isotherm.
3. It is based on experimental evidence and cannot be derived from first principle.

## Thermal Conductivity of Materials

Sl. NO.	Materials	Thermal conductivity, (k)
1	Silver	10 W/mk
2	Copper	85 W/mk
3	Aluminium	25 W/mk
4	Steel	40 W/mk
5	Saw dust	0.07 W/mk

<b>6</b>	Glass wool	0.03 W/mk
<b>7</b>	Freon	0.0083 W/mk
<b>Solid:</b>	A. Pure metals, (k) = 10 to 400 W/mk B. Alloys, (k) = 10 to 120 W/mk C. Insulator, (k) = 0.023 to 2.9 W/mk	
<b>Liquid:</b>	k = 0.2 to 0.5 W/mk	
<b>Gas:</b>	k = 0.006 to 0.5 W/mk	

**Thermal conductivity and temperature:**

$$k = k_0 (1 + \beta t)$$

- |   |                   |
|---|-------------------|
| (i) Metals, $k \downarrow$ if $t \uparrow$ except. $Al, U$<br>(ii) Liquid $k \downarrow$ if $t \uparrow$ except. $H_2O$ | i.e. $\beta, -ve$ |
| (iii) Gas $k \uparrow$ if $t \uparrow$<br>(iv) Non-metal and insulating material $k \uparrow$ if $t \uparrow$           | i.e. $\beta, +ve$ |

**Questions:** Discuss the effects of various parameters on the thermal conductivity of solids.

**Answer:** The following are the effects of various parameters on the thermal conductivity of solids.

- 1. Chemical composition:** Pure metals have very high thermal conductivity. Impurities or alloying elements reduce the thermal conductivity considerably [Thermal conductivity of pure copper is 385 W/m°C, and that for pure nickel is 93 W/m°C. But monel metal (an alloy of 30% Ni and 70% Cu) has k of 24 W/m°C. Again for copper containing traces of Arsenic the value of k is reduced to 142 W/m°C].
- 2. Mechanical forming:** Forging, drawing and bending or heat treatment of metals causes considerable variation in thermal conductivity. For example, the thermal conductivity of hardened steel is lower than that of annealed state.
- 3. Temperature rise:** The value of k for most metals decreases with temperature rise since at elevated temperatures the thermal vibrations of the lattice become higher that retard the motion of free electrons.
- 4. Non-metallic solids:** Non-metallic solids have **k much lower** than that for metals. For many of the building materials (concrete, stone, brick, glass

wool, cork etc.) the thermal conductivity may vary from sample to sample due Fire brick to variations in structure, composition, density and porosity.

5. **Presence of air:** The thermal conductivity is **reduced** due to the presence of air filled pores or cavities.
6. **Dampness:** Thermal conductivity of a damp material is **considerably higher** than that of dry material.
7. **Density:** Thermal conductivity of insulating powder, asbestos etc. increases with density Growth. Thermal conductivity of snow is also proportional to its density.

## Thermal Conductivity of Liquids

$$k = 3\sigma \frac{V_s}{\lambda^2}$$

Where  $\sigma =$  Boltzmann constant per molecule  $\left(\frac{R}{A_v}\right)$

(Don't confused with Stefan Boltzmann Constant)

$V_s =$  Sonic velocity of molecule

$\lambda =$  Distance between two adjacent molecule.

$R =$  Universal gas constant

$A_v =$  Avogadro's number

## Thermal conductivity of gas

$$k = \frac{1}{6} n \bar{v}_s f \sigma \lambda$$

Where  $n =$  Number of molecule/unit volume

$\bar{v}_s =$  Arithmetic mean velocity

$f =$  Number of DOF

$\lambda =$  Molecular mean free path

For **liquid** thermal conductivity lies in the range of 0.08 to 0.6 W/m-k

For **gases** thermal conductivity lies in the range of 0.005 to 0.05 W/m-k

The conductivity of the fluid related to dynamic viscosity ( $\mu$ )

$$k = \left[1 + \frac{4.5}{2n}\right] \mu C_v ;$$

where,  $n =$  number of atoms in a molecule

## Sequence of thermal conductivity

**Pure metals > alloy > non-metallic crystal and amorphous > liquid > gases**

**Wiedemann and Franz Law (based on experimental results)**

“The ratio of the thermal and electrical conductivities is the same for all metals at the same temperature; and that the ratio is directly proportional to the absolute temperature of the metal.”

$$\therefore \frac{k}{\nu} \propto T \quad \text{or} \quad \frac{k}{\nu T} = C$$

Where

$k$  = Thermal conductivity at T(K)

$\nu$  = Electrical conductivity at T(K)

$C$  = Lorenz number =  $2.45 \times 10^{-8} \text{ } \omega\Omega / k^2$

This law conveys that: the metals which are good conductors of electricity are also good conductors of heat. Except **mica**.

### Thermal Resistance: ( $R_{th}$ )

#### Ohm's Law: Flow of Electricity

$$V = IR_{\text{elect}}$$

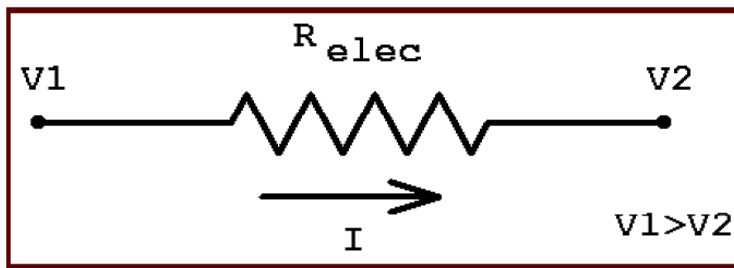

$$\text{Voltage Drop} = \text{Current flow} \times \text{Resistance}$$

#### Thermal Analogy to Ohm's Law:

$$\Delta T = qR_{th}$$

$$\text{Temperature Drop} = \text{Heat Flow} \times \text{Resistance}$$

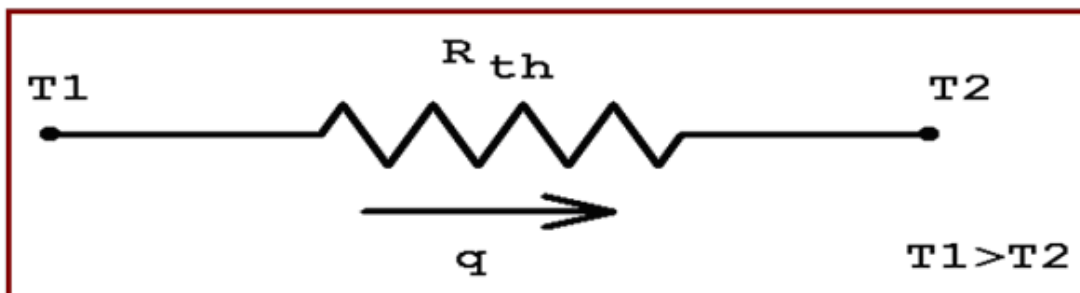

#### A. Conduction Thermal Resistance:

(i)	Slab	$(R_{th}) = \frac{L}{kA}$
(ii)	Hollow cylinder	$(R_{th}) = \frac{\ln(r_2 / r_1)}{2\pi kL}$

(iii)	Hollow sphere	$(R_{th}) = \frac{r_2 - r_1}{4\pi k r_1 r_2}$
-------	---------------	---

B. Convective Thermal Resistance:  $(R_{th}) = \frac{1}{hA}$

C. Radiation Thermal Resistance:  $(R_{th}) = \frac{1}{F\sigma A(T_1 + T_2)(T_1^2 + T_2^2)}$

### 1D Heat Conduction through a Plane Wall

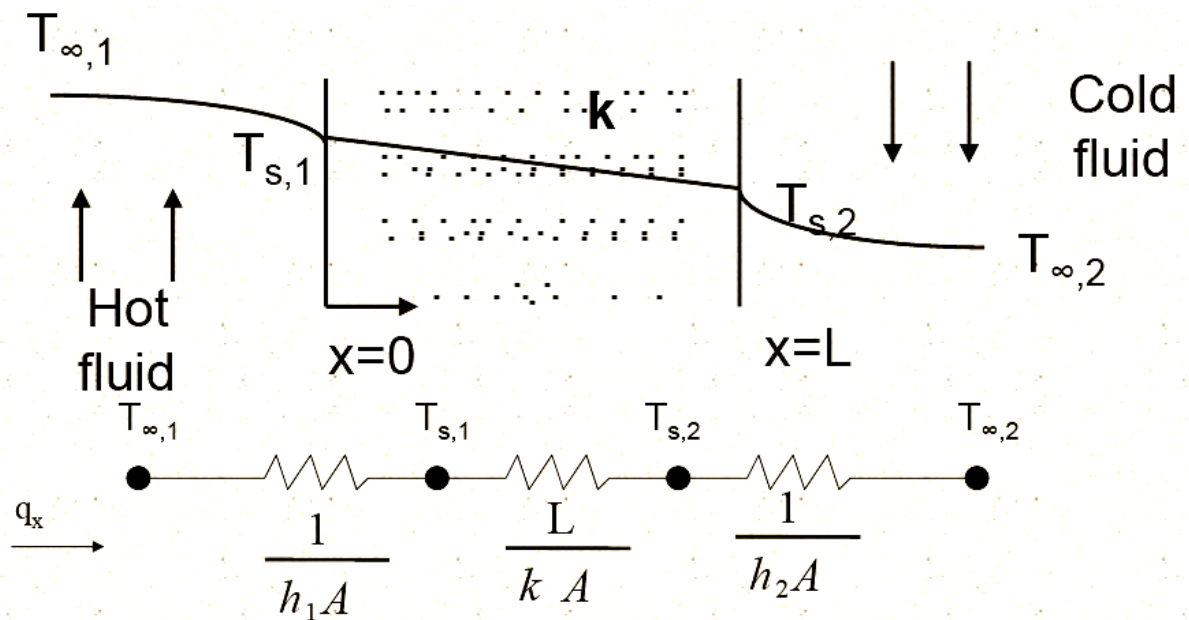

$$\sum R_t = \frac{1}{h_1 A} + \frac{L}{k A} + \frac{1}{h_2 A} \text{ (Thermal resistance)}$$

1D Conduction (Radial conduction in a composite cylinder)

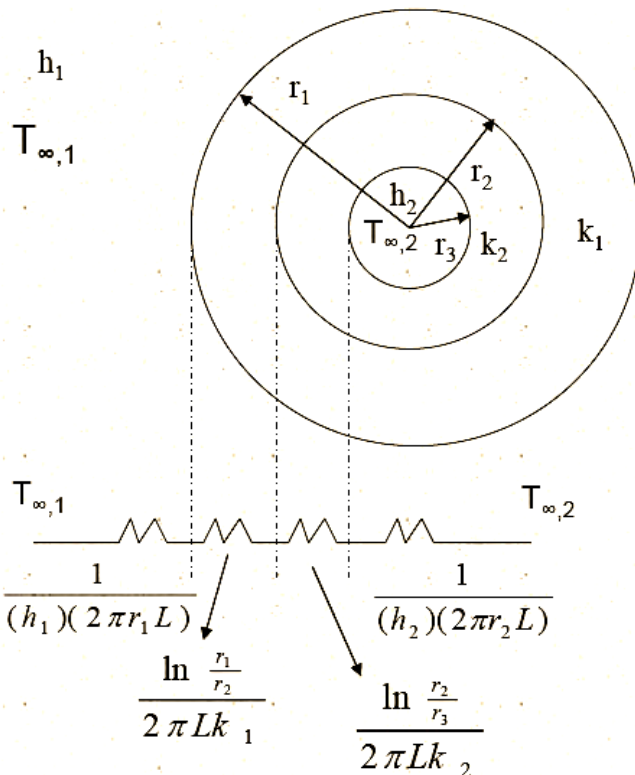

$$q_r = \frac{T_{\infty,2} - T_{\infty,1}}{\sum R_t}$$

1D Conduction in Sphere

Inside Solid:

$$\frac{1}{r^2} \frac{d}{dr} \left( kr^2 \frac{dT}{dr} \right) = 0$$

$$\rightarrow T(r) = T_{s,1} - \{T_{s,1} - T_{s,2}\} \left[ \frac{1 - (r_1/r)}{1 - (r_1/r_2)} \right]$$

$$\rightarrow qr = -kA \frac{dT}{dr} = \frac{4\pi k (T_{s,1} - T_{s,2})}{(1/r_1 - 1/r_2)}$$

$$\rightarrow R_{t,cond} = \frac{1/r_1 - 1/r_2}{4\pi k}$$

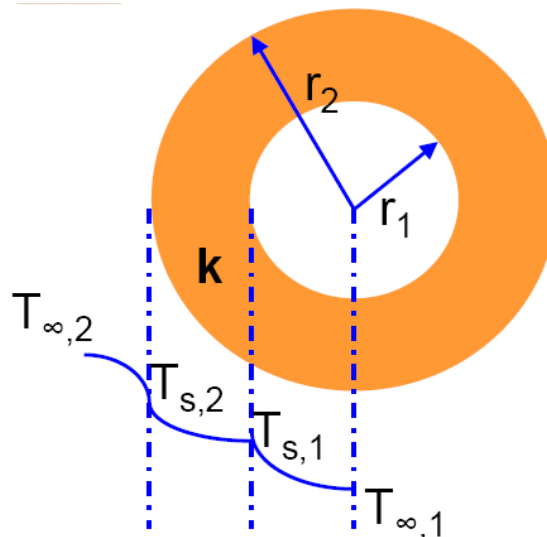

Isotropic & Anisotropic material

If the directional characteristics of a material are **equal/same**, it is called an 'Isotropic material' and if **unequal/different** 'Anisotropic material'.

**Example:** Which of the following is anisotropic, i.e. exhibits change in thermal conductivity due to directional preferences?

(a) Wood

(b) Glass wool

(c) Concrete

(d) Masonry brick

**Answer. (a)**

$$\text{Thermal diffusivity } (\alpha) = \frac{\text{Thermal conductivity } (k)}{\text{Thermal capacity } (\rho c)}$$

$$\text{i.e. } \alpha = \frac{k}{\rho c} \quad \text{unit } \text{m}^2/\text{s}$$

The larger the value of  $\alpha$ , the faster will be the heat diffuse through the material and its temperature will change with time.

- *Thermal diffusivity is an important characteristic quantity for unsteady condition situation.*

OBJECTIVE QUESTIONS (GATE, IES, IAS)

Previous 20-Years GATE Questions

Fourier's Law of Heat Conduction

GATE-1. For a given heat flow and for the same thickness, the temperature drop across the material will be maximum for [GATE-1996]  
 (a) Copper (b) Steel (c) Glass-wool (d) Refractory brick

GATE-2. Steady two-dimensional heat conduction takes place in the body shown in the figure below. The normal temperature gradients over surfaces  $P$  and  $Q$  can be considered to be uniform. The temperature gradient  $\frac{\partial T}{\partial x}$  at surface  $Q$  is equal to  $10 \text{ K/m}$ . Surfaces  $P$  and  $Q$  are maintained at constant temperatures as shown in the figure, while the remaining part of the boundary is insulated. The body has a constant thermal conductivity of  $0.1 \text{ W/m.K}$ . The values of  $\frac{\partial T}{\partial x}$  and  $\frac{\partial T}{\partial y}$  at surface  $P$  are:

- (a)  $\frac{\partial T}{\partial x} = 20 \text{ K/m}, \frac{\partial T}{\partial y} = 0 \text{ K/m}$
- (b)  $\frac{\partial T}{\partial x} = 0 \text{ K/m}, \frac{\partial T}{\partial y} = 10 \text{ K/m}$
- (c)  $\frac{\partial T}{\partial x} = 10 \text{ K/m}, \frac{\partial T}{\partial y} = 10 \text{ K/m}$
- (d)  $\frac{\partial T}{\partial x} = 0 \text{ K/m}, \frac{\partial T}{\partial y} = 20 \text{ K/m}$

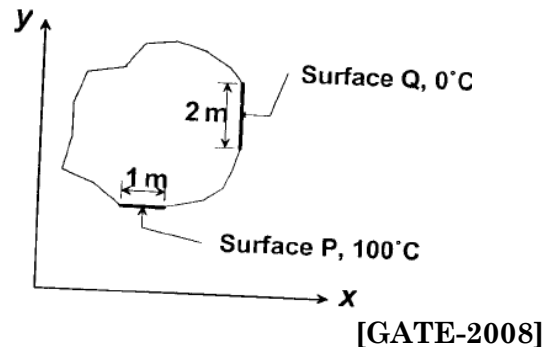

GATE-3. A steel ball of mass 1 kg and specific heat  $0.4 \text{ kJ/kg}$  is at a temperature of  $60^\circ\text{C}$ . It is dropped into 1 kg water at  $20^\circ\text{C}$ . The final steady state temperature of water is: [GATE-1998]  
 (a)  $23.5^\circ\text{C}$  (b)  $300^\circ\text{C}$  (c)  $35^\circ\text{C}$  (d)  $40^\circ\text{C}$

Thermal Conductivity of Materials

GATE-4. In descending order of magnitude, the thermal conductivity of [GATE-2001]  
 a. Pure iron,  
 b. Liquid water,  
 c. Saturated water vapour, and  
 d. Pure aluminium can be arranged as  
 (a) a b c d (b) b c a d (c) d a b c (d) d c b a



Previous 20-Years IES Questions

**Heat Transfer by Conduction**

- IES-1. A copper block and an air mass block having similar dimensions are subjected to symmetrical heat transfer from one face of each block. The other face of the block will be reaching to the same temperature at a rate: [IES-2006]
- (a) Faster in air block
  - (b) Faster in copper block
  - (c) Equal in air as well as copper block
  - (d) Cannot be predicted with the given information

**Fourier's Law of Heat Conduction**

- IES-2. Consider the following statements: [IES-1998]

The Fourier heat conduction equation  $Q = -kA \frac{dT}{dx}$  presumes

1. Steady-state conditions
2. Constant value of thermal conductivity.
3. Uniform temperatures at the wall surfaces
4. One-dimensional heat flow.

Of these statements:

- (a) 1, 2 and 3 are correct
- (b) 1, 2 and 4 are correct
- (c) 2, 3 and 4 are correct
- (d) 1, 3 and 4 are correct

- IES-3. A plane wall is 25 cm thick with an area of 1 m<sup>2</sup>, and has a thermal conductivity of 0.5 W/mK. If a temperature difference of 60°C is imposed across it, what is the heat flow? [IES-2005]
- (a) 120W
  - (b) 140W
  - (c) 160W
  - (d) 180W

- IES-4. A large concrete slab 1 m thick has one dimensional temperature distribution: [IES-2009]

$$T = 4 - 10x + 20x^2 + 10x^3$$

Where  $T$  is temperature and  $x$  is distance from one face towards other face of wall. If the slab material has thermal diffusivity of  $2 \times 10^{-3}$  m<sup>2</sup>/hr, what is the rate of change of temperature at the other face of the wall?

- (a) 0.1°C/h
- (b) 0.2°C/h
- (c) 0.3°C/h
- (d) 0.4°C/h

- IES-5. Thermal diffusivity of a substance is: [IES-2006]

- (a) Inversely proportional to thermal conductivity
- (b) Directly proportional to thermal conductivity
- (c) Directly proportional to the square of thermal conductivity
- (d) Inversely proportional to the square of thermal conductivity

- IES-6. Which one of the following expresses the thermal diffusivity of a substance in terms of thermal conductivity ( $k$ ), mass density ( $\rho$ ) and specific heat ( $c$ )? [IES-2006]

- (a)  $k^2 \rho c$
- (b)  $1/\rho kc$
- (c)  $k/\rho c$
- (d)  $\rho c/k^2$

- IES-7. Match List-I and List-II and select the correct answer using the codes given below the lists: [IES-2001]

$h_m$  - mass transfer coefficient,  
 $D$  - molecular diffusion coefficient,  
 $L$  - characteristic length dimension,  
 $k$  - thermal conductivity,  
 $\rho$  - density,  
 $C_p$  - specific heat at constant pressure,  $\mu$ - dynamic viscosity)

<b>List-I</b>	<b>List-II</b>
A. Schmidt number	1. $\frac{k}{(\rho C_p D)}$
B. Thermal diffusivity	2. $\frac{h_m L}{D}$
C. Lewis number	3. $\frac{\mu}{\rho D}$
D. Sherwood number	4. $\frac{k}{\rho C_p}$

<b>Codes:</b>	<b>A</b>	<b>B</b>	<b>C</b>	<b>D</b>		<b>A</b>	<b>B</b>	<b>C</b>	<b>D</b>
(a)	4	3	2	1	(b)	4	3	1	2
(c)	3	4	2	1	(d)	3	4	1	2

**IES-8. Match List-I with List-II and select the correct answer using the codes given below the lists: [IES-1996]**

<b>List-I</b>	<b>List-II</b>
A. Momentum transfer	1. Thermal diffusivity
B. Mass transfer	2. Kinematic viscosity
C. Heat transfer	3. Diffusion coefficient

<b>Codes:</b>	<b>A</b>	<b>B</b>	<b>C</b>		<b>A</b>	<b>B</b>	<b>C</b>
(a)	2	3	1	(b)	1	3	2
(c)	3	2	1	(d)	1	2	3

**IES-9. Assertion (A): Thermal diffusivity is a dimensionless quantity. Reason (R): In M-L-T-Q system the dimensions of thermal diffusivity are  $[L^2T^{-1}]$  [IES-1992]**

- (a) Both A and R are individually true and R is the correct explanation of A
- (b) Both A and R are individually true but R is **not** the correct explanation of A
- (c) A is true but R is false
- (d) A is false but R is true

**IES-10. A furnace is made of a red brick wall of thickness 0.5 m and conductivity 0.7 W/mK. For the same heat loss and temperature drop, this can be replaced by a layer of diatomite earth of conductivity 0.14 W/mK and thickness [IES-1993]**

- (a) 0.05 m
- (b) 0.1 m
- (c) 0.2 m
- (d) 0.5 m

**IES-11. Temperature profiles for four cases are shown in the following figures and are labelled A, B, C and D.**

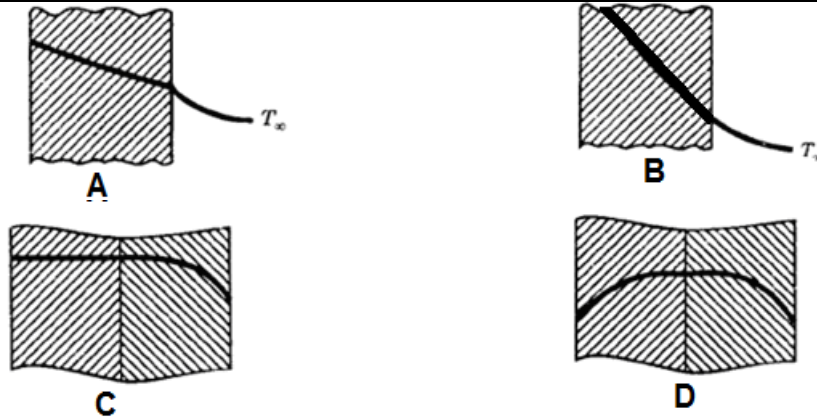

Match the above figures with

1. High conductivity fluid
2. Low conductivity fluid
3. Insulating body
4. Guard heater

[IES-1998]

Select the correct answer using the codes given below:

Codes:	<b>A</b>	<b>B</b>	<b>C</b>	<b>D</b>	<b>A</b>	<b>B</b>	<b>C</b>	<b>D</b>
(a)	1	2	3	4	(b)	2	1	3
(c)	1	2	4	3	(d)	2	1	4

## Thermal Conductivity of Materials

IES-12. Match the following:

[IES-1992]

List-I

- A. Normal boiling point of oxygen
- B. Normal boiling point of sulphur
- C. Normal melting point of Antimony
- D. Normal melting point of Gold

List-II

1. 1063°C
2. 630.5°C
3. 444°C
4. -182.97°C

Codes:	<b>A</b>	<b>B</b>	<b>C</b>	<b>D</b>	<b>A</b>	<b>B</b>	<b>C</b>	<b>D</b>
(a)	4	2	3	1	(b)	4	3	1
(c)	4	2	3	1	(d)	4	3	2

IES-13. Assertion (A): The leakage heat transfer from the outside surface of a steel pipe carrying hot gases is reduced to a greater extent on providing refractory brick lining on the inside of the pipe as compared to that with brick lining on the outside. [IES-2000]

Reason (R): The refractory brick lining on the inside of the pipe offers a higher thermal resistance.

- (a) Both A and R are individually true and R is the correct explanation of A
- (b) Both A and R are individually true but R is **not** the correct explanation of A
- (c) A is true but R is false
- (d) A is false but R is true

IES-14. Assertion (A): Hydrogen cooling is used for high capacity electrical generators. [IES-1992]

Reason (R): Hydrogen is light and has high thermal conductivity as compared to air.

- (a) Both A and R are individually true and R is the correct explanation of A
- (b) Both A and R are individually true but R is **not** the correct explanation of A
- (c) A is true but R is false
- (d) A is false but R is true

- IES-15.** In MLT  $\theta$  system ( $T$  being time and  $\theta$  temperature), what is the dimension of thermal conductivity? [IES-2009]  
 (a)  $ML^{-1}T^{-1}\theta^{-3}$  (b)  $MLT^{-1}\theta^{-1}$  (c)  $ML\theta^{-1}T^{-3}$  (d)  $ML\theta^{-1}T^{-2}$
- IES-16.** Assertion (A): Cork is a good insulator. [IES-2009]  
 Reason (R): Good insulators are highly porous.  
 (a) Both A and R are individually true and R is the correct explanation of A  
 (b) Both A and R individually true but R is not the correct explanation of A  
 (c) A is true but R is false  
 (d) A is false but R is true
- IES-17.** In which one of the following materials, is the heat energy propagation minimum due to conduction heat transfer? [IES-2008]  
 (a) Lead (b) Copper (c) Water (d) Air
- IES-18.** Assertion (A): Non-metals are having higher thermal conductivity than metals. [IES-2008]  
 Reason (R): Free electrons in the metals are higher than those of non metals.  
 (a) Both A and R are true and R is the correct explanation of A  
 (b) Both A and R are true but R is NOT the correct explanation of A  
 (c) A is true but R is false  
 (d) A is false but R is true

Answers with Explanation (Objective)

Previous 20-Years GATE Answers

**GATE-1. Ans. (c)**  $Q = -kA \frac{dT}{dx}$

$$\frac{Qdx}{A} = -kdT \quad \therefore kdT = \text{constant} \quad \text{or } dT \propto \frac{1}{k}$$

Which one has minimum thermal conductivity that will give maximum temperature drop.

**GATE-2. Ans. (d)** Heat entry = Heat exit

$$(2 \times B) \frac{dT}{dx} = (1 \times B) \frac{dT}{dy}$$

**GATE-3. Ans. (a)** Heat loss by hot body = Heat gain by cold body

$$m_h c_{ph} (t_h - t_f) = m_c c_{pc} (t_f - t_c)$$

$$\text{or } 1 \times 0.4 \times (60 - t_f) = 1 \times 4.2 \times (t_f - 20) \quad \text{or } t_f = 13.5^\circ\text{C}$$

**GATE-4. Ans. (c)**

Previous 20-Years IES Answers

**IES-1. Ans. (b)**

**IES-2. Ans. (d)** Thermal conductivity may constant or variable.

**IES-3. Ans. (a)**  $Q = kA \frac{dT}{dx} = 0.5 \times 1 \times \frac{60}{0.25} \text{ W} = 120 \text{ W}$

**IES-4. Ans. (b)**  $\frac{\partial T}{\partial x} = -10 + 40x + 30x^2 \quad \Rightarrow \quad \frac{\partial^2 T}{\partial x^2} = 40 + 60x$

$$\left. \frac{\partial^2 T}{\partial x^2} \right|_{x=1} = \frac{1}{\alpha} \frac{\partial T}{\partial \tau} \quad \Rightarrow \quad 40 + 60(1) = \left( \frac{1}{2 \times 10^{-3}} \right) \frac{\partial T}{\partial \tau}$$

$$\Rightarrow \frac{\partial T}{\partial \tau} = (2 \times 10^{-3})(100) = 0.2^\circ\text{C}/\text{hour}$$

**IES-5. Ans. (b)** Thermal diffusivity  $(\alpha) = \frac{k}{\rho c_p}$ ;  $\therefore \alpha \propto k$

**IES-6. Ans. (c)**  $\alpha = \frac{k}{\rho c_p}$

**IES-7. Ans. (d)**

**IES-8. Ans. (a)**

**IES-9. Ans. (d)**

**IES-10. Ans. (b)** For thick place homogeneous wall, heat loss =  $kA \frac{dt}{dx}$

$$\text{or} \left( 0.7 \times A \times \frac{dt}{0.5} \right)_{\text{red brick}} = \left( 0.14 \times A \frac{dt}{dx} \right)_{\text{diatomic}} \quad \text{or } \Delta x = 0.1m \quad [ \because dt = \text{constant} ]$$

**IES-11. Ans. (a)** Temperature slope is higher for low conducting and lower for high conducting fluid. Thus A is for 1, B for 2. Temperature profile in C is for insulator. Temperature rise is possible only for heater and as such D is for guard heater.

**IES-12. Ans. (d)**

**IES-13. Ans. (a)**

**IES-14. Ans. (a)** It reduces the cooling systems size.

**IES-15. Ans. (c)**  $Q = -KA \frac{dT}{dx}; (ML^2T^{-3}) = K(L^2) \frac{(\theta)}{(L)}$

$$\Rightarrow ML^2T^{-3} = K(L)(\theta) \qquad \Rightarrow K = \frac{ML^2T^{-3}}{L\theta} = [MLT^{-3}\theta^{-1}]$$

**IES-16. Ans. (a)**

**IES-17. Ans. (d)** Heat energy propagation minimum due to conduction heat transfer in case of Air as its thermal conductivity is high.

**IES-18. Ans. (d)** Non-metals have lower thermal conductivity and free electrons in metal higher than non metal therefore (d) is the answer.



## One Dimensional Steady State Conduction

Theory at a Glance (For IES, GATE, PSU)

### General Heat Conduction Equation in Cartesian Coordinates

Recognize that heat transfer involves an energy transfer across a system boundary. A logical place to begin studying such process is from Conservation of Energy (1<sup>st</sup> Law of – Thermodynamics) for a closed system:

$$\left. \frac{dE}{dt} \right|_{system} = \dot{Q}_{in} - \dot{W}_{out}$$

The sign convention on work is such that negative work out is positive work in:

$$\left. \frac{dE}{dt} \right|_{system} = \dot{Q}_{in} + \dot{W}_{out}$$

The work in term could describe an electric current flow across the system boundary and through a resistance inside the system. Alternatively it could describe a shaft turning across the system boundary and overcoming friction within the system. The net effect in either case would cause the internal energy of the system to rise. In heat transfer we generalize all such terms as “heat sources”.

$$\left. \frac{dE}{dt} \right|_{system} = \dot{Q}_{in} + \dot{Q}_{gen}$$

The energy of the system will in general include internal energy, (U), potential energy, ( $\frac{1}{2} \mathbf{mgz}$ ), or kinetic energy, ( $\frac{1}{2} m v^2$ ). In case of heat transfer problems, the latter two terms could often be neglected. In this case,

$$E = U = m \cdot u = m \cdot c_p \cdot (T - T_{ref}) = \rho \cdot V \cdot c_p \cdot (T - T_{ref})$$

Where  $T_{ref}$  is the reference temperature at which the energy of the system is defined as zero. When we differentiate the above expression with respect to time, the reference temperature, being constant disappears:

$$\rho \cdot c_p \cdot V \cdot \left. \frac{dT}{dt} \right|_{system} = \dot{Q}_{in} + \dot{Q}_{gen}$$

Consider the differential control element shown below. Heat is assumed to flow through the element in the positive directions as shown by the 6-heat vectors.

# One Dimensional Steady State Conduction

**S K Mondal's****Chapter 2**

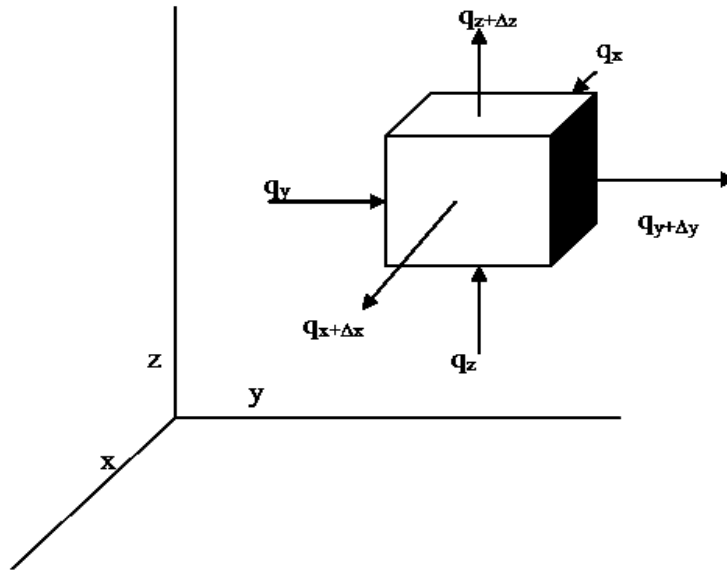

In the equation above we substitute the 6-heat inflows/outflows using the appropriate sign:

$$\rho \cdot c_p \cdot (\Delta x \cdot \Delta y \cdot \Delta z) \cdot \left. \frac{dT}{dt} \right|_{system} = q_x - q_{x+\Delta x} + q_y - q_{y+\Delta y} + q_z - q_{z+\Delta z} + \dot{Q}_{gen}$$

Substitute for each of the conduction terms using the Fourier Law:

$$\begin{aligned} \rho \cdot c_p \cdot (\Delta x \cdot \Delta y \cdot \Delta z) \cdot \left. \frac{dT}{dt} \right|_{system} &= \left\{ -\mathbf{k} \cdot (\Delta y \cdot \Delta z) \cdot \frac{\partial T}{\partial x} - \left[ -\mathbf{k} \cdot (\Delta y \cdot \Delta z) \cdot \frac{\partial T}{\partial x} + \frac{\partial}{\partial x} \left( -\mathbf{k} \cdot (\Delta y \cdot \Delta z) \cdot \frac{\partial T}{\partial x} \right) \cdot \Delta x \right] \right\} \\ &+ \left\{ -\mathbf{k} \cdot (\Delta x \cdot \Delta z) \cdot \frac{\partial T}{\partial y} - \left[ -\mathbf{k} \cdot (\Delta x \cdot \Delta z) \cdot \frac{\partial T}{\partial y} + \frac{\partial}{\partial y} \left( -\mathbf{k} \cdot (\Delta x \cdot \Delta z) \cdot \frac{\partial T}{\partial y} \right) \cdot \Delta y \right] \right\} \\ &+ \left\{ -\mathbf{k} \cdot (\Delta x \cdot \Delta y) \cdot \frac{\partial T}{\partial z} + \left[ -\mathbf{k} \cdot (\Delta x \cdot \Delta y) \cdot \frac{\partial T}{\partial z} + \frac{\partial}{\partial z} \left( -\mathbf{k} \cdot (\Delta x \cdot \Delta y) \cdot \frac{\partial T}{\partial z} \right) \cdot \Delta z \right] \right\} \\ &+ \dot{q}_g (\Delta x \cdot \Delta y \cdot \Delta z) \end{aligned}$$

Where  $\dot{q}_g$  is defined as the internal heat generation per unit volume.

The above equation reduces to:

$$\begin{aligned} \rho \cdot c_p \cdot (\Delta x \cdot \Delta y \cdot \Delta z) \cdot \left. \frac{dT}{dt} \right|_{system} &= \left\{ - \left[ \frac{\partial}{\partial x} \left( -\mathbf{k} \cdot (\Delta y \cdot \Delta z) \cdot \frac{\partial T}{\partial x} \right) \right] \cdot \Delta x \right\} \\ &+ \left\{ - \left[ \frac{\partial}{\partial y} \left( -\mathbf{k} \cdot (\Delta x \cdot \Delta z) \cdot \frac{\partial T}{\partial y} \right) \right] \cdot \Delta y \right\} \\ &+ \left\{ \left[ \frac{\partial}{\partial z} \left( -\mathbf{k} \cdot (\Delta x \cdot \Delta y) \cdot \frac{\partial T}{\partial z} \right) \right] \cdot \Delta z \right\} + \dot{q}_g \cdot (\Delta x \cdot \Delta y \cdot \Delta z) \end{aligned}$$

Dividing by the volume ( $\Delta x \cdot \Delta y \cdot \Delta z$ ),

$$\rho \cdot c_p \cdot \left. \frac{dT}{dt} \right|_{system} = - \frac{\partial}{\partial x} \left( -\mathbf{k} \cdot \frac{\partial T}{\partial x} \right) - \frac{\partial}{\partial y} \left( -\mathbf{k} \cdot \frac{\partial T}{\partial y} \right) - \frac{\partial}{\partial z} \left( -\mathbf{k} \cdot \frac{\partial T}{\partial z} \right) + \dot{q}_g$$



<h2 style="margin: 0;">One Dimensional Steady State Conduction</h2> <h1 style="margin: 0;">S K Mondal's</h1> <h2 style="margin: 0; text-align: right;">Chapter 2</h2>
---

Which is the **general conduction equation** in three dimensions. In the case where  $k$  is independent of  $x$ ,  $y$  and  $z$  then

$$\frac{\rho \cdot c_p}{k} \cdot \frac{dT}{dt} \Big|_{system} = \frac{\partial^2 T}{\partial x^2} + \frac{\partial^2 T}{\partial y^2} + \frac{\partial^2 T}{\partial z^2} + \frac{\dot{q}_g}{k}$$

**Define the thermodynamic property,  $\alpha$ , the thermal diffusivity:**

$$\alpha = \frac{k}{\rho \cdot c_p}$$

Then

$$\frac{1}{\alpha} \cdot \frac{dT}{dt} \Big|_{system} = \frac{\partial^2 T}{\partial x^2} + \frac{\partial^2 T}{\partial y^2} + \frac{\partial^2 T}{\partial z^2} + \frac{\dot{q}_g}{k}$$

or,

$$\frac{1}{\alpha} \cdot \frac{dT}{dt} \Big|_{system} = \nabla^2 T + \frac{\dot{q}_g}{k}$$

The vector form of this equation is quite compact and is the most general form. However, we often find it convenient to expand the del-squared term in specific coordinate systems:

### General Heat Conduction equation:

$$\frac{\partial}{\partial x} \left( k_x \frac{\partial T}{\partial x} \right) + \frac{\partial}{\partial y} \left( k_y \frac{\partial T}{\partial y} \right) + \frac{\partial}{\partial z} \left( k_z \frac{\partial T}{\partial z} \right) + \dot{q}_g = \rho c \frac{\partial T}{\partial \tau} \quad \text{i.e. } \nabla \cdot (k \nabla T) + \dot{q}_g = \rho c \frac{\partial T}{\partial \tau}$$

For: – Non-homogeneous material.  
 Self-heat generating.  
 Unsteady three- dimensional heat flow.

### Fourier's equation:

$$\frac{\partial^2 T}{\partial x^2} + \frac{\partial^2 T}{\partial y^2} + \frac{\partial^2 T}{\partial z^2} = \frac{1}{\alpha} \frac{\partial T}{\partial \tau}$$

or,  $\nabla^2 T = \frac{1}{\alpha} \cdot \frac{\partial T}{\partial \tau}$

**Material:** Homogeneous, isotropic  
**State:** Unsteady state  
**Generation:** Without internal heat generation.

### Poisson's equation:

$$\frac{\partial^2 T}{\partial x^2} + \frac{\partial^2 T}{\partial y^2} + \frac{\partial^2 T}{\partial z^2} + \frac{\dot{q}_g}{k} = 0$$

or

$$\nabla^2 T + \frac{\dot{q}_g}{k} = 0$$

Material: Homo, isotopic.  
 State: Steady.

Generation: With heat generation.

**Laplace equation:**

$$\frac{\partial^2 T}{\partial x^2} + \frac{\partial^2 T}{\partial y^2} + \frac{\partial^2 T}{\partial z^2} = 0$$

or

$$\nabla^2 T = 0$$

Material: Homogeneous, isotopic.

State: Steady.

Generation: Without heat generation.

**General Heat Conduction Equation in Cylindrical Coordinates**

$$\left[ \frac{\partial^2 T}{\partial r^2} + \frac{1}{r} \frac{\partial T}{\partial r} + \frac{1}{r^2} \frac{\partial^2 T}{\partial \phi^2} + \frac{\partial^2 T}{\partial z^2} \right] + \frac{\dot{q}_g}{k} = \frac{1}{\alpha} \frac{\partial T}{\partial \tau}$$

For steady, one - D, without heat generation.

$$\frac{\partial^2 T}{\partial r^2} + \frac{1}{r} \frac{\partial T}{\partial r} = 0 \quad \text{i.e.} \quad \frac{d}{dr} \left( r \frac{dT}{dr} \right) = 0$$

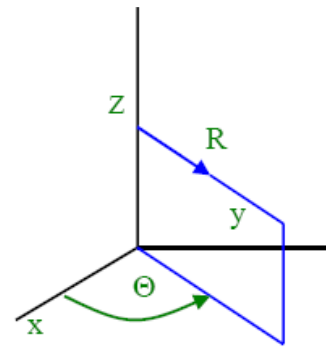

**General Heat Conduction Equation in Spherical Coordinates**

$$\frac{1}{r^2} \frac{\partial}{\partial r} \left( r^2 \cdot \frac{\partial T}{\partial r} \right) + \frac{1}{r^2 \sin \theta} \cdot \frac{\partial}{\partial \theta} \left( \sin \theta \frac{\partial T}{\partial \theta} \right) + \frac{1}{r^2 \sin^2 \theta} \cdot \frac{\partial^2 T}{\partial \phi^2} + \frac{\dot{q}_g}{k} = \frac{1}{\alpha} \cdot \frac{\partial T}{\partial \tau}$$

For one - D, steady, without heat generation

$$\frac{d}{dr} \left( r^2 \frac{dT}{dr} \right) = 0$$

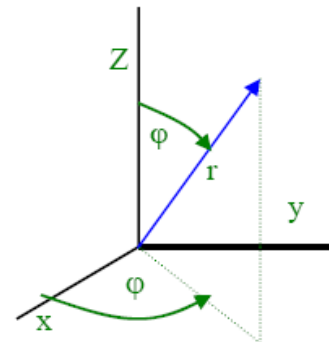

- **Steady State:** steady state solution implies that the system condition is not changing with time. Thus  $\partial T / \partial \tau = 0$ .
- **One dimensional:** If heat is flowing in only one coordinate direction, then it follows  
That there is no temperature gradient in the other two directions. Thus the two partials associated with these directions are equal to zero.
- **Two dimensional:** If heat is flowing in only two coordinate directions, then it follows  
That there is no temperature gradient in the third direction. Thus the partial derivative associated with this third direction is equal to zero.

# One Dimensional Steady State Conduction

**S K Mondal's****Chapter 2**

- **No Sources:** If there are no heat sources within the system then the term,  $\dot{q}_g = 0$ .

**Note:** For temperature distribution only, use conduction equation

Otherwise: Use  $Q = -kA \frac{dT}{dx}$

Every time  $Q = -kA \frac{dT}{dx}$  will give least complication to the calculation.

### Heat Diffusion Equation for a One Dimensional System

Consider the system shown above. The top, bottom, front and back of the cube are insulated. So that heat can be conducted through the cube only in the  $x$ -direction. The internal heat generation per unit volume is  $\dot{q}_g$  ( $\text{W/m}^3$ ).

Consider the heat flow through an arbitrary differential element of the cube.

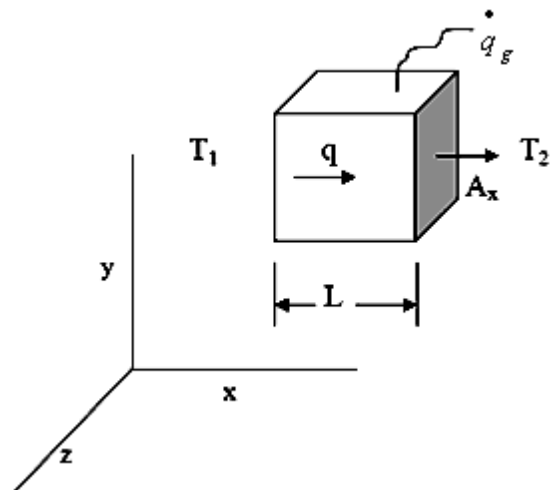

From the 1<sup>st</sup> Law we write for the element:

$$(\dot{E}_{in} - \dot{E}_{out}) + \dot{E}_{gen} = \dot{E}_{st}$$

$$q_x - q_{x+\Delta x} + A_x (\Delta x) \dot{q}_g = \frac{\partial E}{\partial t}$$

$$q_x = -kA_x \frac{\partial T}{\partial x}$$

$$q_{x+\Delta x} = q_x + \frac{\partial q_x}{\partial x} \Delta x$$

$$-kA_x \frac{\partial T}{\partial x} + kA_x \frac{\partial T}{\partial x} + A_x \frac{\partial}{\partial x} \left( k \frac{\partial T}{\partial x} \right) \Delta x + A_x \Delta x \dot{q}_g = \rho A_x c \Delta x \frac{\partial T}{\partial t}$$

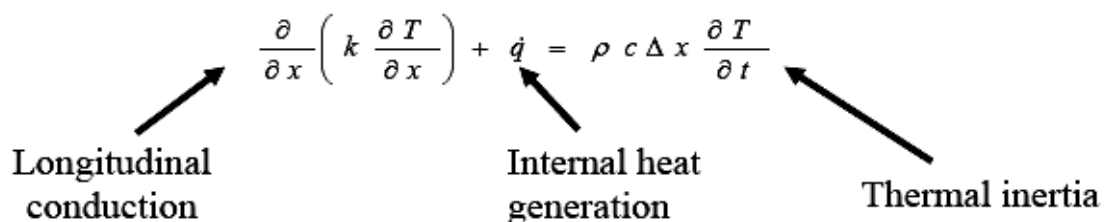
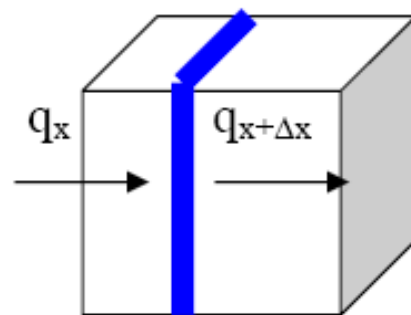

$$\frac{\partial^2 T}{\partial x^2} + \frac{\dot{q}_g}{k} = \frac{\rho c}{k} \frac{\partial T}{\partial t} = \frac{1}{\alpha} \frac{\partial T}{\partial t} \quad (\text{When } k \text{ is constant})$$

- For T to rise, LHS must be positive (heat input is positive)
- For a fixed heat input, T rises faster for higher  $\alpha$
- In this special case, heat flow is 1D. If sides were not insulated, heat flow could be 2D, 3D.

## Heat Conduction through a Plane Wall

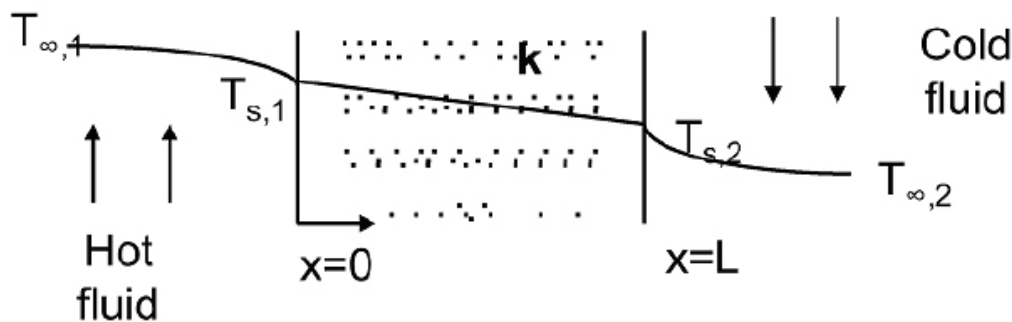

The differential equation governing heat diffusion is:  $\frac{d}{dx} \left( k \frac{dT}{dx} \right) = 0$

With constant  $k$ , the above equation may be integrated twice to obtain the general solution:

$$T(x) = C_1 x + C_2$$

Where  $C_1$  and  $C_2$  are constants of integration. To obtain the constants of integration, we apply the boundary conditions at  $x = 0$  and  $x = L$ , in which case

$$T(0) = T_{s,1} \quad \text{And} \quad T(L) = T_{s,2}$$

Once the constants of integration are substituted into the general equation, the temperature distribution is obtained:

$$T(x) = (T_{s,2} - T_{s,1}) \frac{x}{L} + T_{s,1}$$

The heat flow rate across the wall is given by:

$$q_x = -kA \frac{dT}{dx} = \frac{kA}{L} (T_{s,1} - T_{s,2}) = \frac{T_{s,1} - T_{s,2}}{L / kA}$$

### Thermal resistance (electrical analogy):

Physical systems are said to be analogous if that obey the same mathematical equation. The above relations can be put into the form of Ohm's law:

$$V = IR_{elec}$$

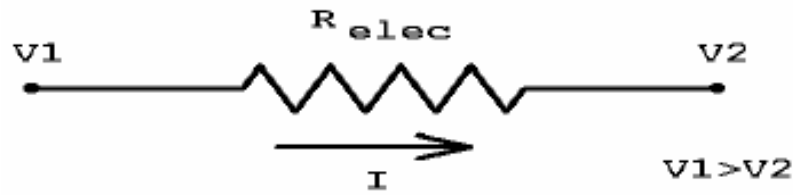

Using this terminology it is common to speak of a thermal resistance:

$$\Delta T = qR_{th}$$

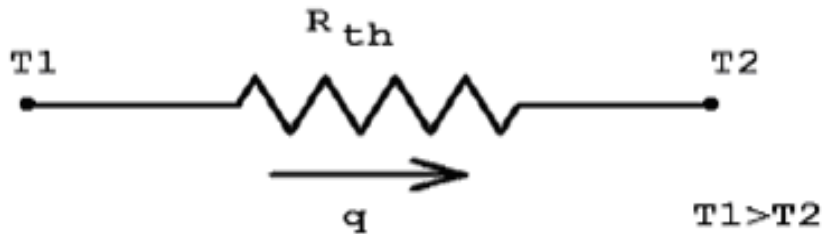

A thermal resistance may also be associated with heat transfer by convection at a surface. From Newton's law of cooling,

$$q = hA(T_s - T_\infty)$$

The thermal resistance for convection is then

$$R_{t,conv.} = \frac{T_s - T_\infty}{q} = \frac{1}{hA}$$

Applying thermal resistance concept to the plane wall, the equivalent thermal circuit for the plane wall with convection boundary conditions is shown in the figure below:

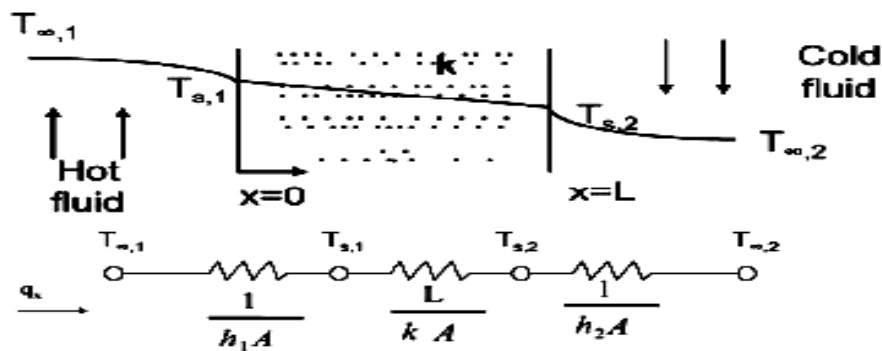

The heat transfer rate may be determined from separate consideration of each element in the network. Since  $q_x$  is constant throughout the network, it follows that

$$q_x = \frac{T_{\infty,1} - T_{s,1}}{1/h_1 A} = \frac{T_{s,1} - T_{s,2}}{L/kA} = \frac{T_{s,2} - T_{\infty,2}}{1/h_2 A}$$

In terms of the overall temperature difference  $T_{\infty,1} - T_{\infty,2}$ , and the total thermal resistance  $R_{tot}$ , The heat transfer rate may also be expressed as

$$q_x = \frac{T_{\infty,1} - T_{\infty,2}}{R_{tot}}$$

Since the resistances are in series, it follows that

$$R_{tot} = \sum R_t = \frac{1}{h_1 A} + \frac{L}{kA} + \frac{1}{h_2 A}$$

### Uniform thermal conductivity

$$T = T_1 - \frac{T_1 - T_2}{L} \times x \Rightarrow \frac{T - T_1}{T_2 - T_1} = \frac{x}{L}$$

$$Q = \frac{T_1 - T_2}{(L/kA)} = \frac{T_1 - T_2}{(R_{th})_{cond.}}$$

Variable thermal conductivity,  $k = k_o (1 + \beta T)$

Use  $Q = -kA \frac{dT}{dx}$  and integrate for t and Q both

$$\therefore Q = k_m A \frac{T_1 - T_2}{L}$$

$$\text{and } T = -\frac{1}{\beta} + \left[ \left( T_1 + \frac{1}{\beta} \right)^2 - \frac{2Qx}{\beta k_o A} \right]^{1/2}$$

$$\text{Where } k_m = k_o \left[ 1 + \beta \frac{(T_1 + T_2)}{2} \right] = k_o (1 + \beta T_m)$$

If  $k = k_o f(t)$  Then,  $k_m = \frac{k_o}{(T_2 - T_1)} \int_{T_1}^{T_2} f(T) dt$

### Heat Conduction through a Composite Wall

Consider three blocks, A, B and C, as shown. They are insulated on top, bottom, front and Back. Since the energy will flow first through block A and then through blocks B and C, we Say that these blocks are thermally in a series arrangement.

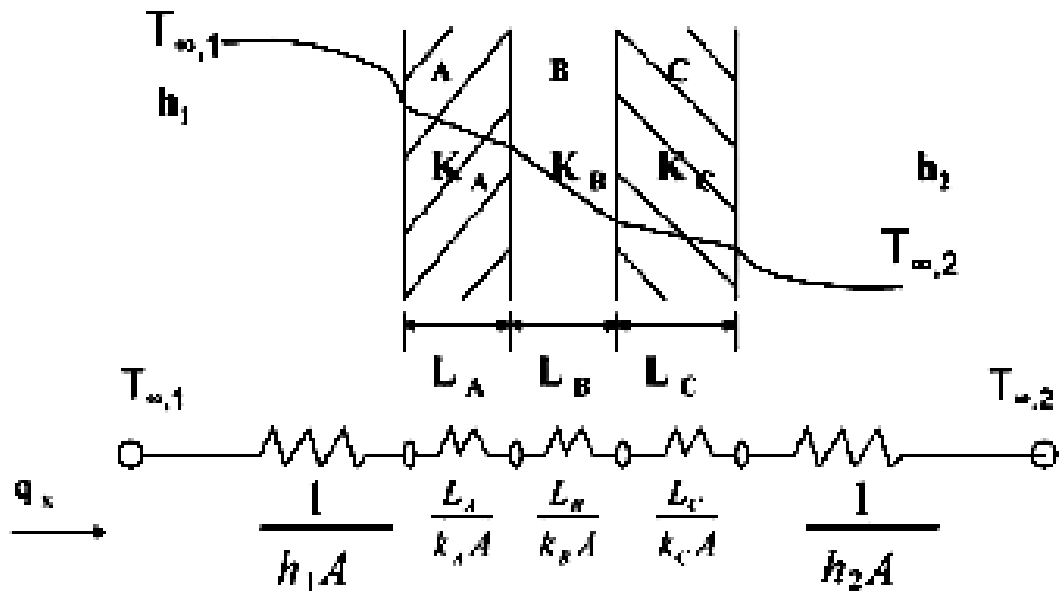

The steady state heat flow rate through the walls is given by:

$$q_x = \frac{T_{\infty,1} - T_{\infty,2}}{\sum R_t} = \frac{T_{\infty,1} - T_{\infty,2}}{\frac{1}{h_1 A} + \frac{L_A}{k_A A} + \frac{L_B}{k_B A} + \frac{1}{h_2 A}} = UA\Delta T$$

Where  $U = \frac{1}{R_{tot} A}$  is the overall heat transfer coefficient. In the above case, U is expressed as

$$U = \frac{1}{\frac{1}{h_1} + \frac{L_A}{k_A} + \frac{L_B}{k_B} + \frac{L_C}{k_C} + \frac{1}{h_2}}$$

Series-parallel arrangement:

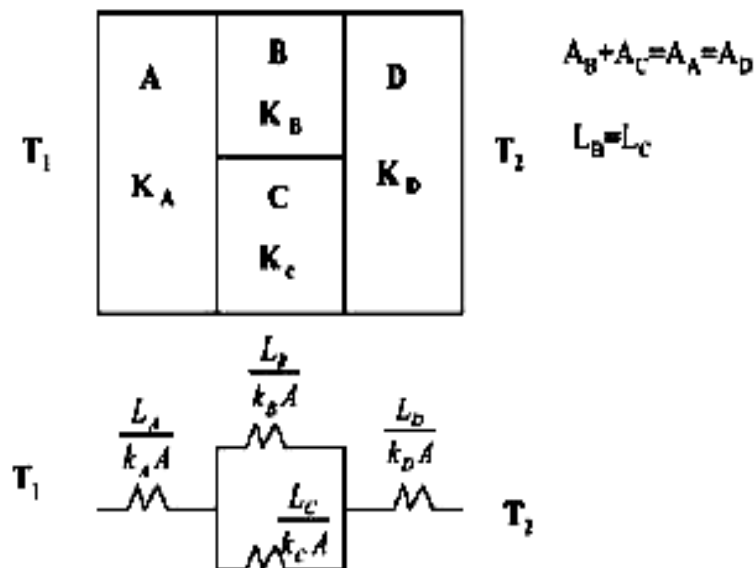

The following assumptions are made with regard to the above thermal resistance model:

- 1) Face between B and C is insulated.
- 2) Uniform temperature at any face normal to X.

### Equivalent Thermal Resistance

The common mistake student do is they take length of equivalent conductor as L but it must be 2L. Then equate the thermal resistance of them.

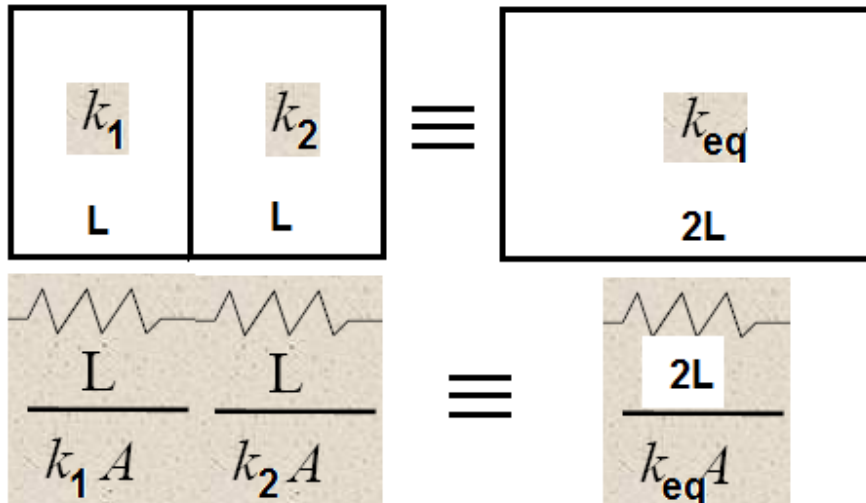

### The Overall Heat Transfer Coefficient

Composite Walls:

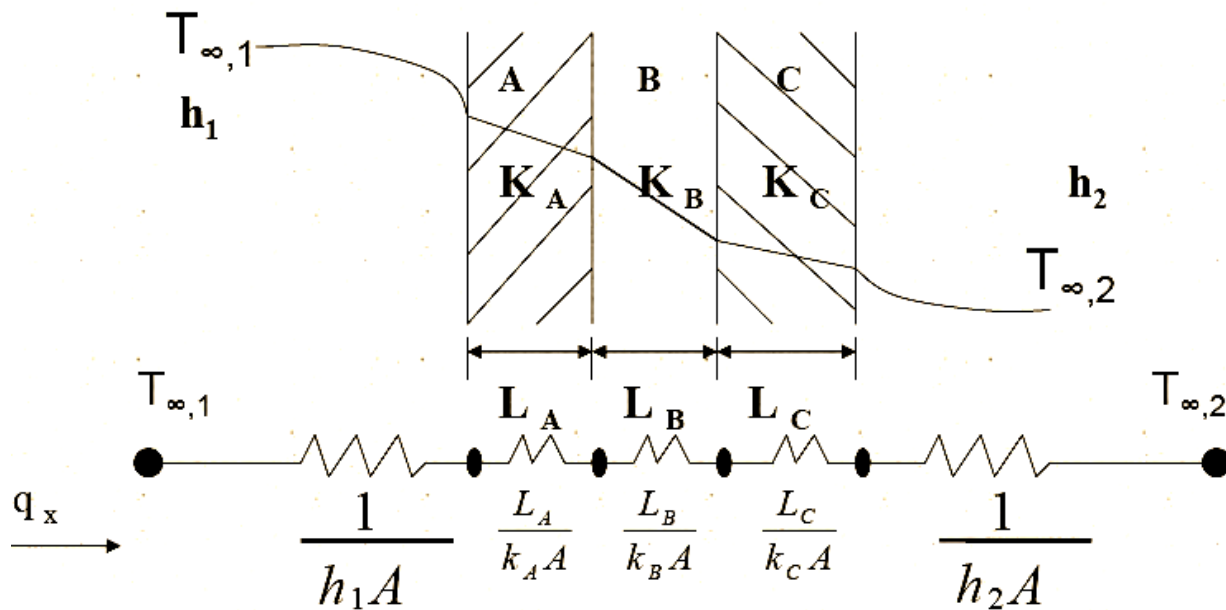

$$q_x = \frac{T_{\infty,1} - T_{\infty,2}}{\sum R_t} = \frac{T_{\infty,1} - T_{\infty,2}}{\frac{1}{h_1 A} + \frac{L_A}{k_A A} + \frac{L_B}{k_B A} + \frac{L_C}{k_C A} + \frac{1}{h_2 A}} = UA \Delta T$$



### Overall Heat Transfer Coefficient

$$U = \frac{1}{R_{\text{total}} A} = \frac{1}{\frac{1}{h_1} + \sum \frac{L}{k} + \frac{1}{h_2}}$$

$$U = \frac{1}{\frac{1}{h_1} + \frac{L_A}{k_A} + \frac{L_B}{k_B} + \frac{L_C}{k_C} + \frac{1}{h_2}}$$

### Heat Conduction through a Hollow Cylinder

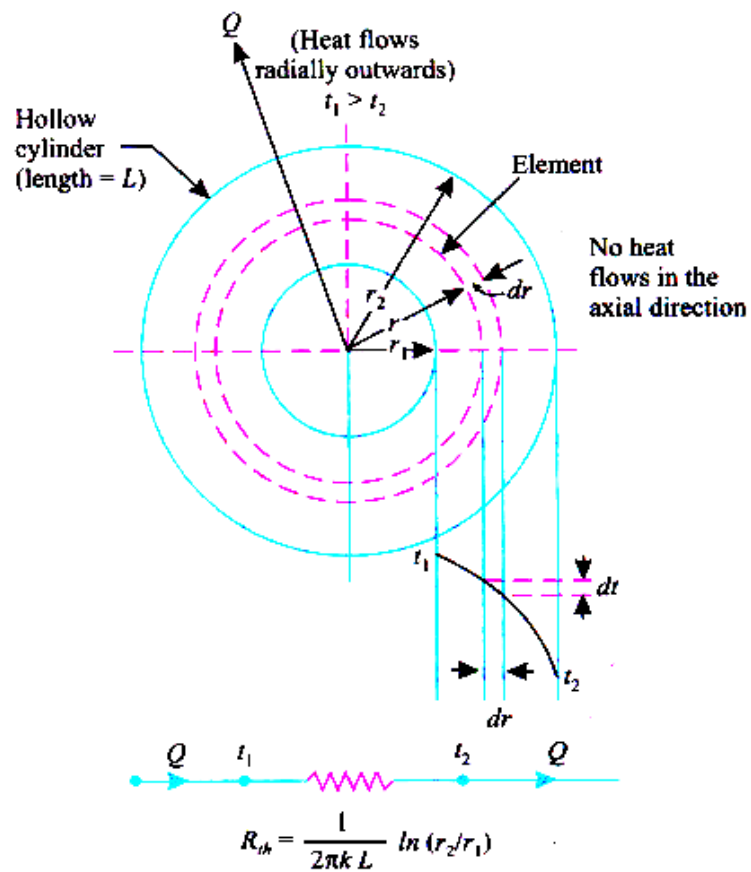

**Uniform conductivity**

For temperature distribution,

$$\frac{d}{dr} \left( r \cdot \frac{dt}{dr} \right) = 0$$

$$\therefore \frac{t - t_1}{t_2 - t_1} = \frac{\ln(r / r_1)}{\ln(r_2 / r_1)}$$

For Q, use  $Q = -k(2\pi rL) \frac{dt}{dr}$

$$\therefore Q = \frac{t_1 - t_2}{\frac{\ln(r_2 / r_1)}{2\pi kL}}$$

**Variable thermal conductivity,  $k = k_o (1 + \beta t)$**

Use  $Q = -k A \frac{dt}{dr}$   
 $= -k_o (1 + \beta t) 2\pi rL \frac{dt}{dr}$

then  $Q = \frac{2\pi k_o L \left[ 1 + \frac{\beta}{2} (t_1 + t_2) \right] (t_1 - t_2)}{\ln(r_2 / r_1)} = \frac{t_1 - t_2}{\frac{\ln(r_2 / r_1)}{2\pi k_m L}}$

and

$$t = -\frac{1}{\beta} \pm \frac{1}{\beta} \left[ (1 + \beta t_1)^2 - \frac{\ln(r / r_1)}{\ln(r_2 / r_1)} \{ (1 + \beta t_1)^2 - (1 + \beta t_2)^2 \} \right]^{1/2}$$

$$= -\frac{1}{\beta} + \left[ \left( t_1 + \frac{1}{\beta} \right)^2 - \frac{Q}{\beta k_o} \cdot \frac{\ln(r / r_1)}{\pi L} \right]^{1/2}$$

**Logarithmic Mean Area for the Hollow Cylinder**

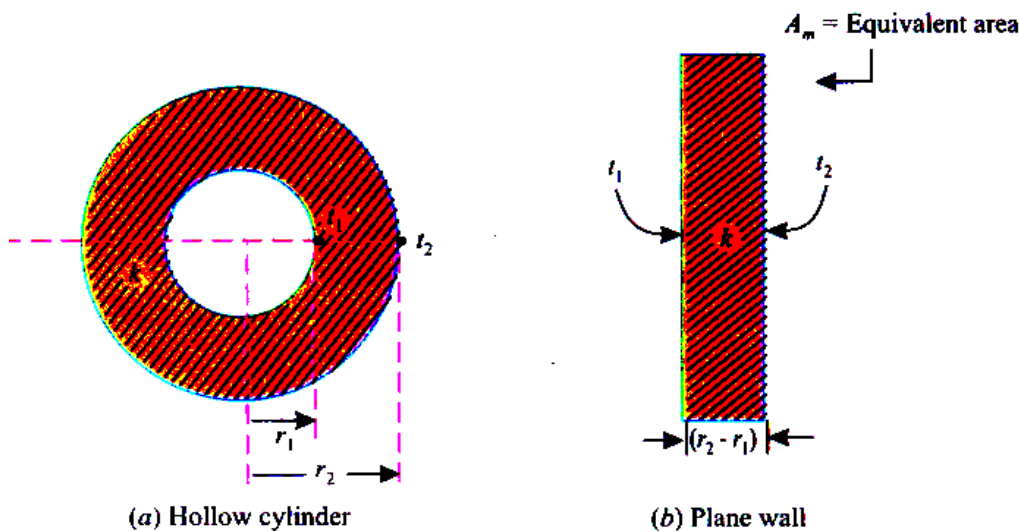

Invariably it is considered convenient to have an expression for the heat flow through a hollow cylinder of the same form as that for a plane wall. Then thickness will be equal to  $(r_2 - r_1)$  and the area A will be an equivalent area  $A_m$  shown in the diagram. Now, expressions for heat flow through the hollow cylinder and plane wall will be as follows.

$$Q = \frac{(t_1 - t_2)}{\frac{\ln(r_2 / r_1)}{2\pi kL}}$$

Heat flows through cylinder

**One Dimensional Steady State Conduction**  
**S K Mondal's** **Chapter 2**

$$Q = \frac{(t_1 - t_2)}{\frac{(r_2 - r_1)}{k A_m}} \quad \text{Heat flow through plane wall}$$

$A_m$  is so chosen that heat flow through cylinder and plane wall be equal for the same thermal potential.

$$\frac{(t_1 - t_2)}{\frac{\ln(r_2 / r_1)}{2\pi k L}} = \frac{(t_1 - t_2)}{\frac{(r_2 - r_1)}{k A_m}}$$

or. 
$$\frac{\ln(r_2 / r_1)}{2\pi k L} = \frac{(r_2 - r_1)}{k A_m}$$

or 
$$A_m = \frac{2\pi L(r_2 - r_1)}{\ln(r_2 / r_1)} = \frac{2\pi L r_2 - 2\pi L r_1}{\ln(2\pi L r_2 / 2\pi L r_1)}$$

or 
$$A_m = \frac{A_2 - A_1}{\ln\left(\frac{A_2}{A_1}\right)}$$

Where  $A_1$  and  $A_2$  are inside and outside surface areas of the cylinder.

### Heat Conduction through a Composite Cylinder

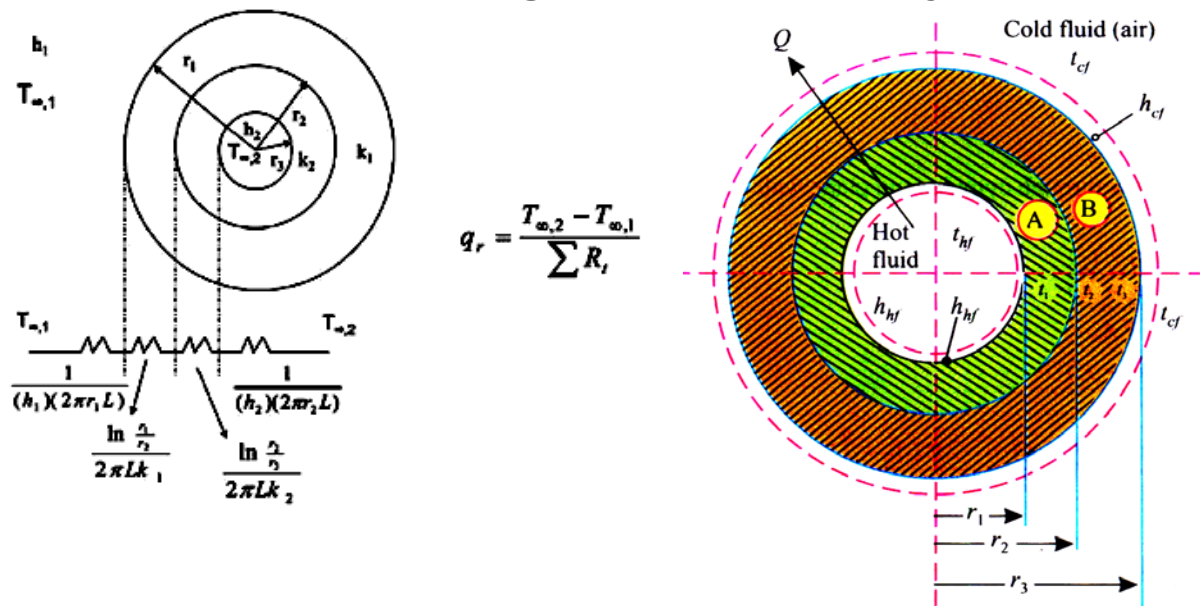

Heat Conduction through a Composite Cylinder

$$Q = \frac{2\pi L(t_{hf} - t_{cf})}{\frac{1}{h_{hf}r_1} + \sum_1^n \frac{\ln(r_{n+1}/r_n)}{k_n} + \frac{1}{h_{cf}r_{n+1}}}$$

**Thermal Resistance for an Eccentric Hollow Tube**

$$R_{th} = \frac{1}{2\pi kL} \times \ln \left[ \frac{\left\{ (r_2 + r_1)^2 - e^2 \right\}^{\frac{1}{2}} + \left\{ (r_2 - r_1)^2 - e^2 \right\}^{\frac{1}{2}}}{\left\{ (r_2 + r_1)^2 - e^2 \right\}^{\frac{1}{2}} - \left\{ (r_2 - r_1)^2 - e^2 \right\}^{\frac{1}{2}}} \right]$$

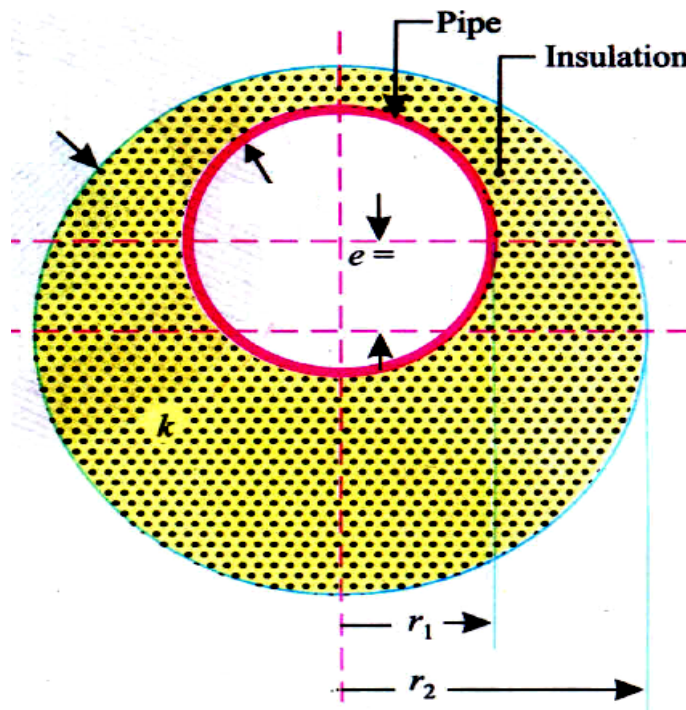

**Conduction through Circular Conical Rod**

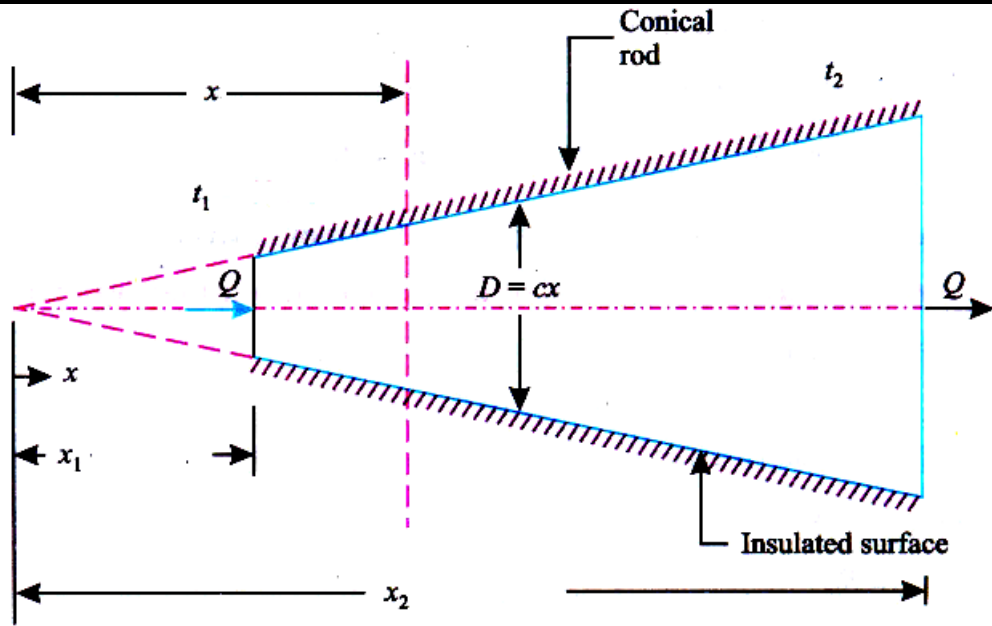

Use  $Q = -kA \frac{dt}{dx} = -k \frac{\pi}{4} c^2 x^2 \frac{dt}{dx}$

$$\therefore 4Q \int_{x_1}^{x_2} \frac{dx}{x^2} = -\pi k c^2 \int_{t_1}^{t_2} dt$$

### Heat Conduction through a Hollow Sphere

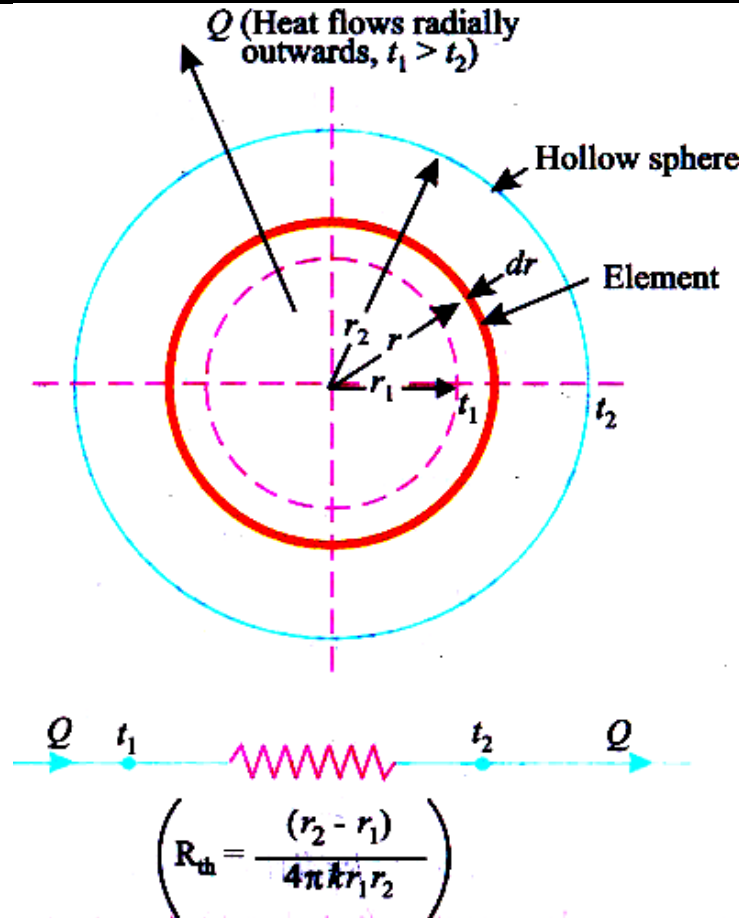

**Uniform Conductivity**

For temperature Distribution

use,  $\frac{d}{dr} \left( r^2 \frac{dt}{dr} \right) = 0$

$$\frac{t - t_1}{t_2 - t_1} = \frac{r_2}{r} \times \frac{[r - r_1]}{[r_2 - r_1]} = \frac{\left( \frac{1}{r} - \frac{1}{r_1} \right)}{\left( \frac{1}{r_2} - \frac{1}{r_1} \right)}$$

For Q, Use  $Q = -KA \frac{dt}{dr} = -k 4\pi r^2 \frac{dt}{dr}$

$$\therefore Q = \frac{t_1 - t_2}{\frac{r_2 - r_1}{4\pi k r_1 r_2}} \quad \therefore R_{th} = \frac{r_2 - r_1}{4\pi k r_1 r_2}$$

**For variable conductivity:**

For both Q, and t use  $Q = -k(4\pi r^2) \frac{dt}{dr}$   
and

$$Q = \frac{t_1 - t_2}{\frac{r_2 - r_1}{4\pi k_m r_1 r_2}}, \quad \left( K_m = \frac{+k_0}{t_2 - t_1} \int_{t_1}^{t_2} f(t) dt \right)$$

**Logarithmic Mean Area for the Hollow Sphere**

For slab

For cylinder

For sphere

**One Dimensional Steady State Conduction**  
**S K Mondal's** **Chapter 2**

$$Q = \frac{t_1 - t_2}{\left(\frac{L}{kA}\right)}$$

$$Q = \frac{t_1 - t_2}{\frac{\ln(r_2 / r_1)}{2\pi kL}} \equiv \frac{t_1 - t_2}{\frac{r_2 - r_1}{kA_m}}$$

$$\Rightarrow A_m = \frac{A_2 - A_1}{\ln(A_2 / A_1)}$$

$$\Rightarrow r_m = \frac{r_2 - r_1}{\ln(r_2 / r_1)}$$

$$Q = \frac{t_1 - t_2}{\frac{r_2 - r_1}{4\pi k r_1 r_2}} = \frac{t_1 - t_2}{\frac{r_2 - r_1}{kA_m}}$$

$$\Rightarrow A_m = \sqrt{A_2 A_1}$$

$$\Rightarrow r_m = \sqrt{r_2 r_1}$$

**Heat Condition**

**through a Composite Sphere**

$$Q = \frac{4\pi(t_{hf} - t_{cf})}{\frac{1}{h_{hf} r_1^2} + \sum_1^n \frac{r_{n+1} - r_n}{k_n r_n r_{n+1}} + \frac{1}{h_{cf} r_{n+1}^2}}$$

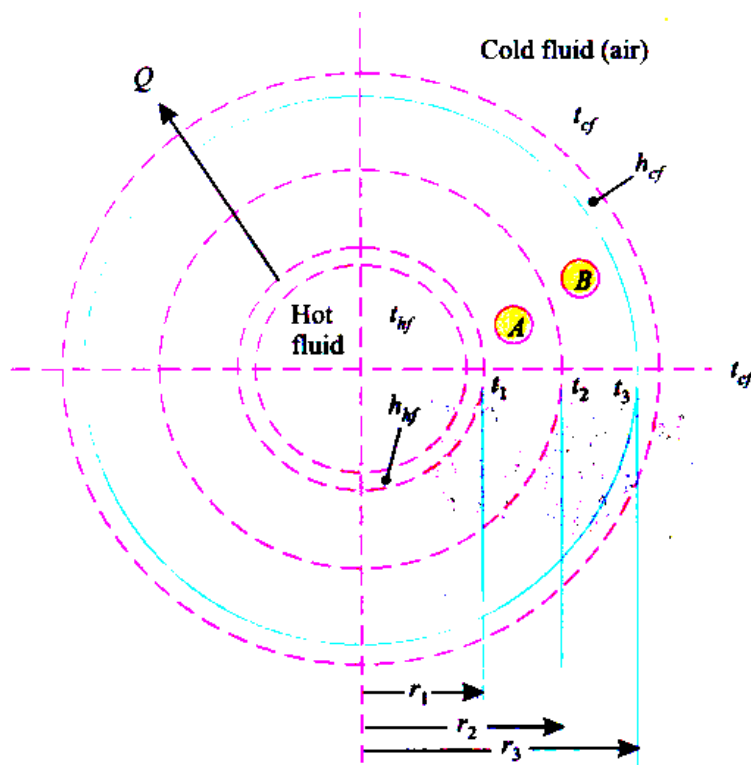

**HEAT FLOW RATE (Remember)**

a) Slab,  $Q = \frac{T_1 - T_2}{\frac{L}{kA}}$

Composite slab,  $Q = \frac{T_g - T_a}{\frac{1}{h_0 A} + \frac{1}{h_i A} + \sum \frac{L}{kA}}$

**b) Cylinder,** 
$$Q = \frac{2\pi L(T_1 - T_2)}{\left\{ \frac{\ln\left(\frac{r_2}{r_1}\right)}{k} \right\}}$$

**Composite cylinder,** 
$$Q = \frac{2\pi L(T_g - T_a)}{\frac{1}{h_i r_1} + \frac{1}{h_o r_{n+1}} + \sum \frac{\ln\left(\frac{r_{n+1}}{r_n}\right)}{k_n}};$$

$$A_m = \frac{A_2 - A_1}{\ln\left(\frac{A_2}{A_1}\right)}$$

**c) Sphere,** 
$$Q = \frac{4\pi(T_1 - T_2)}{\left\{ \frac{r_2 - r_1}{kr_1 r_2} \right\}}$$

**Composite sphere,** 
$$Q = \frac{4\pi(T_g - T_a)}{\frac{1}{h_i r_1^2} + \frac{1}{h_o r_{n+1}^2} + \sum \frac{r_{n+1} - r_n}{k_n r_{n+1} r_n}};$$

$$A_m = \sqrt{A_1 A_2}$$



**OBJECTIVE QUESTIONS (GATE, IES, IAS)**

**Previous 20-Years GATE Questions**

**General Heat Conduction Equation in Cartesian Coordinates**

GATE-1. In a case of one dimensional heat conduction in a medium with constant properties,  $T$  is the temperature at position  $x$ , at time  $t$ . Then  $\frac{\partial T}{\partial t}$  is proportional to: [GATE-2005]

- (a)  $\frac{T}{x}$                       (b)  $\frac{\partial T}{\partial x}$                       (c)  $\frac{\partial^2 T}{\partial x \partial t}$                       (d)  $\frac{\partial^2 T}{\partial x^2}$

**General Heat Conduction Equation in Spherical Coordinates**

GATE-2. One dimensional unsteady state heat transfer equation for a sphere with heat generation at the rate of 'q' can be written as [GATE-2004]

- (a)  $\frac{1}{r} \frac{\partial}{\partial r} \left( r \frac{\partial T}{\partial r} \right) + \frac{q}{k} = \frac{1}{\alpha} \frac{\partial T}{\partial t}$                       (b)  $\frac{1}{r^2} \frac{\partial}{\partial r} \left( r^2 \frac{\partial T}{\partial r} \right) + \frac{q}{k} = \frac{1}{\alpha} \frac{\partial T}{\partial t}$   
(c)  $\frac{\partial^2 T}{\partial r^2} + \frac{q}{k} = \frac{1}{\alpha} \frac{\partial T}{\partial t}$                       (d)  $\frac{\partial^2}{\partial r^2} + (rT) + \frac{q}{k} = \frac{1}{\alpha} \frac{\partial T}{\partial t}$

**Heat Conduction through a Plane Wall**

GATE-3. A building has to be maintained at 21°C (dry bulb) and 14.5°C. The outside temperature is -23°C (dry bulb) and the internal and external surface heat transfer coefficients are 8 W/m<sup>2</sup>K and 23 W/m<sup>2</sup>K respectively. If the building wall has a thermal conductivity of 1.2 W/mK, the minimum thickness (in m) of the wall required to prevent condensation is: [GATE-2007]

- (a) 0.471                      (b) 0.407                      (c) 0.321                      (d) 0.125

GATE-4. For the three-dimensional object shown in the figure below, five faces are insulated. The sixth face (PQRS), which is not insulated, interacts thermally with the ambient, with a convective heat transfer coefficient of 10 W/m<sup>2</sup>.K. The ambient temperature is 30°C. Heat is uniformly generated inside the object at the rate of 100 W/m<sup>3</sup>. Assuming the face PQRS to be at uniform temperature, its steady state temperature is:

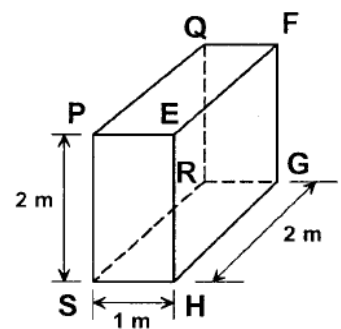

- (a) 10°C                      (b) 20°C                      (c) 30°C                      (d) 40°C [GATE-2008]

Heat Conduction through a Composite Wall

GATE-5. Consider steady-state heat conduction across the thickness in a plane composite wall (as shown in the figure) exposed to convection conditions on both sides.

Given:  $h_i = 20 \text{ W/m}^2\text{K}$ ;  $h_o = 50 \text{ W/m}^2\text{K}$ ;  $T_{\infty,i} = 20^\circ\text{C}$ ;  $T_{\infty,o} = -2^\circ\text{C}$ ;  $k_1 = 20 \text{ W/mK}$ ;  $k_2 = 50 \text{ W/mK}$ ;  $L_1 = 0.30 \text{ m}$  and  $L_2 = 0.15 \text{ m}$ . Assuming negligible contact resistance between the wall surfaces, the interface temperature,  $T$  (in  $^\circ\text{C}$ ), of the two walls will be:

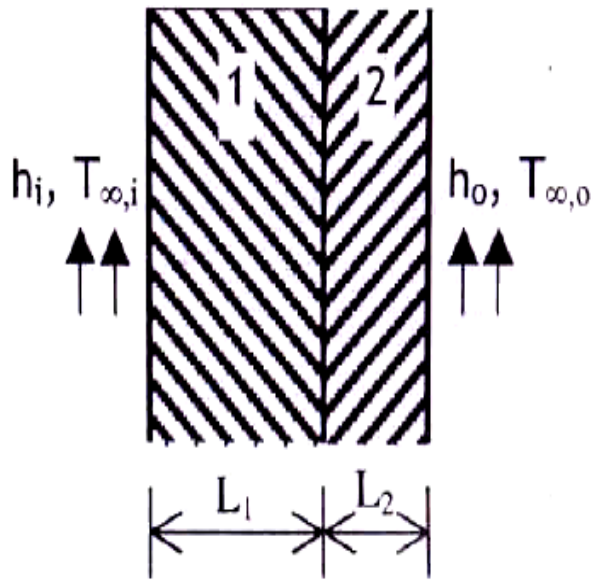

[GATE-2009]

- (a) - 0.50                      (b) 2.75                      (c) 3.75                      (d) 4.50

GATE-6. In a composite slab, the temperature at the interface ( $T_{inter}$ ) between two materials is equal to the average of the temperatures at the two ends. Assuming steady one-dimensional heat conduction, which of the following statements is true about the respective thermal conductivities?

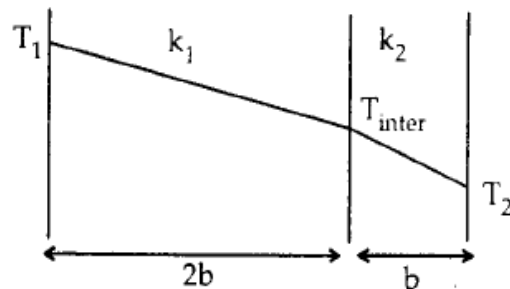

[GATE-2006]

- (a)  $2k_1 = k_2$                       (b)  $k_1 = k_2$                       (c)  $2k_1 = 3k_2$                       (d)  $k_1 = 2k_2$

GATE-7. Heat flows through a composite slab, as shown below. The depth of the slab is 1 m. The  $k$  values are in  $\text{W/mK}$ . the overall thermal resistance in  $\text{K/W}$  is:

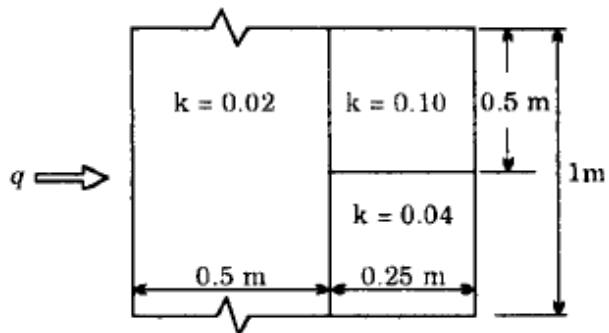

[GATE-2005]

- (a) 17.                      (b) 21.9  
(c) 28.6                      (d) 39.2

**GATE-8.** The temperature variation under steady heat conduction across a composite slab of two materials with thermal conductivities  $K_1$  and  $K_2$  is shown in figure. Then, which one of the following statements holds?

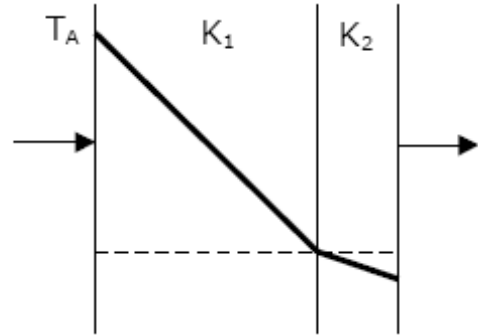

- (a)  $K_1 > K_2$                       (b)  $K_1 = K_2$   
 (c)  $K_1 = 0$                           (d)  $K_1 < K_2$

[GATE-1998]

### Heat Conduction through a Composite Cylinder

**GATE-9.** A stainless steel tube ( $k_s = 19 \text{ W/mK}$ ) of 2 cm ID and 5 cm OD is insulated with 3 cm thick asbestos ( $k_a = 0.2 \text{ W/mK}$ ). If the temperature difference between the innermost and outermost surfaces is  $600^\circ\text{C}$ , the heat transfer rate per unit length is: [GATE-2004]

- (a) 0.94 W/m                      (b) 9.44 W/m                      (c) 944.72 W/m                      (d) 9447.21 W/m

**GATE-10.** Two insulating materials of thermal conductivity  $K$  and  $2K$  are available for lagging a pipe carrying a hot fluid. If the radial thickness of each material is the same. [GATE-1994]

- (a) Material with higher thermal conductivity should be used for the inner layer and one with lower thermal conductivity for the outer.  
 (b) Material with lower thermal conductivity should be used for the inner layer and one with higher thermal conductivity for the outer.  
 (c) It is immaterial in which sequence the insulating materials are used.  
 (d) It is not possible to judge unless numerical values of dimensions are given.

## Previous 20-Years IES Questions

### Heat Conduction through a Plane Wall

**IES-1.** A wall of thickness 0.6 m has width has a normal area  $1.5 \text{ m}^2$  and is made up of material of thermal conductivity  $0.4 \text{ W/mK}$ . The temperatures on the two sides are  $800^\circ\text{C}$ . What is the thermal resistance of the wall? [IES-2006; 2007]

- (a) 1 W/K                      (b) 1.8 W/K                      (c) 1 K/W                      (d) 1.8 K/W

**IES-2.** Two walls of same thickness and cross sectional area have thermal conductivities in the ratio 1 : 2. If same temperature difference is maintained across the two faces of both the walls, what is the ratio of heat flow  $Q_1/Q_2$ ? [IES-2008]

- (a)  $\frac{1}{2}$                       (b) 1                      (c) 2                      (d) 4

**IES-3.** A composite wall of a furnace has 2 layers of equal thickness having thermal conductivities in the ratio of 3 : 2. What is the ratio of the temperature drop across the two layers? [IES-2008]

- (a) 2:3                      (b) 3: 2                      (c) 1: 2                      (d)  $\log_e 2: \log_e 3$

**IES-4.**

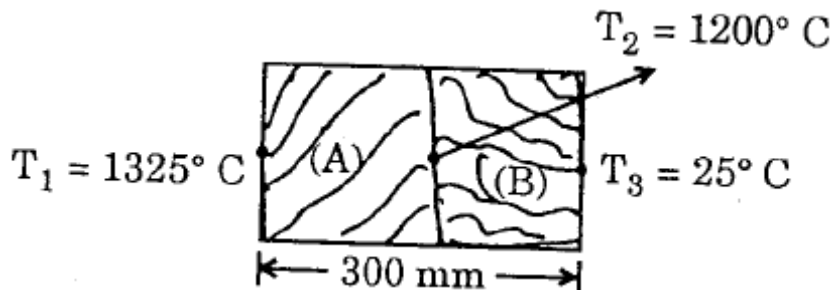

A wall as shown above is made up of two layers (A) and (B). The temperatures are also shown in the sketch. The ratio of thermal conductivity of two layers is  $\frac{k_A}{k_B} = 2$ . [IES-2008]

What is the ratio of thickness of two layers?

- (a) 0.105                      (b) 0.213                      (c) 0.555                      (d) 0.840

**IES-5.** Heat is conducted through a 10 cm thick wall at the rate of 30 W/m<sup>2</sup> when the temperature difference across the wall is 10°C. What is the thermal conductivity of the wall? [IES-2005]

- (a) 0.03 W/mK              (b) 0.3 W/mK              (c) 3.0 W/mK              (d) 30.0 W/mK

**IES-6.** A 0.5 m thick plane wall has its two surfaces kept at 300°C and 200°C. Thermal conductivity of the wall varies linearly with temperature and its values at 300°C and 200°C are 25 W/mK and 15W/mK respectively. Then the steady heat flux through the wall is: [IES-2002]

- (a) 8 kW/m<sup>2</sup>                      (b) 5 kW/m<sup>2</sup>                      (c) 4kW/m<sup>2</sup>                      (d) 3 kW/m<sup>2</sup>

**IES-7.** 6.0 kJ of conduction heat transfer has to take place in 10 minutes from one end to other end of a metallic cylinder of 10 cm<sup>2</sup> cross-sectional area, length 1 meter and thermal conductivity as 100 W/mK. What is the temperature difference between the two ends of the cylindrical bar? [IES-2005]

- (a) 80°C                      (b) 100°C                      (c) 120°C                      (d) 160°C

**IES-8.** A steel plate of thermal conductivity 50 W/m-K and thickness 10 cm passes a heat flux by conduction of 25 kW/m<sup>2</sup>. If the temperature of the hot surface of the plate is 100°C, then what is the temperature of the cooler side of the plate? [IES-2009]

- (a) 30°C                      (b) 40°C                      (c) 50°C                      (d) 60°C

**One Dimensional Steady State Conduction**  
**S K Mondal's** **Chapter 2**

IES-9. In a large plate, the steady temperature distribution is as shown in the given figure. If no heat is generated in the plate, the thermal conductivity 'k' will vary as ( $T$  is temperature and  $\alpha$  is a constant)

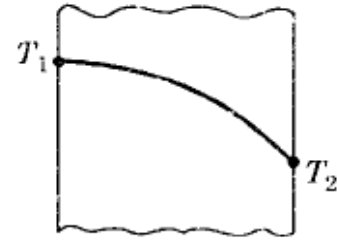

[IES-1997]

- (a)  $k_0(1 + \alpha T)$       (b)  $k_0(1 - \alpha T)$       (c)  $1 + \alpha T$       (d)  $1 - \alpha T$

IES-10. The temperature distribution, at a certain instant of time in a concrete slab during curing is given by  $T = 3x^2 + 3x + 16$ , where  $x$  is in cm and  $T$  is in K. The rate of change of temperature with time is given by (assume diffusivity to be  $0.0003 \text{ cm}^2/\text{s}$ ).

[IES-1994]

- (a)  $+ 0.0009 \text{ K/s}$     (b)  $+ 0.0048 \text{ K/s}$     (c)  $- 0.0012 \text{ K/s}$     (d)  $- 0.0018 \text{ K/s}$

### Heat Conduction through a Composite Wall

IES-11. A composite wall having three layers of thickness 0.3 m, 0.2 m and 0.1 m and of thermal conductivities 0.6, 0.4 and 0.1 W/mK, respectively, is having surface area  $1 \text{ m}^2$ . If the inner and outer temperatures of the composite wall are 1840 K and 340 K, respectively, what is the rate of heat transfer?

[IES-2007]

- (a) 150 W      (b) 1500 W      (c) 75 W      (d) 750 W

IES-12. A composite wall of a furnace has 3 layers of equal thickness having thermal conductivities in the ratio of 1:2:4. What will be the temperature drop ratio across the three respective layers?

[IES-2009]

- (a) 1:2:4      (b) 4:2:1      (c) 1:1:1      (d)  $\log 4 : \log 2 : \log 1$

IES-13. What is the heat lost per hour across a wall 4 m high, 10 m long and 115 mm thick, if the inside wall temperature is  $30^\circ\text{C}$  and outside ambient temperature is  $10^\circ\text{C}$ ? Conductivity of brick wall is  $1.15 \text{ W/mK}$ , heat transfer coefficient for inside wall is  $2.5 \text{ W/m}^2\text{K}$  and that for outside wall is  $4 \text{ W/m}^2\text{K}$ .

[IES-2009]

- (a) 3635 kJ      (b) 3750 kJ      (c) 3840 kJ      (d) 3920 kJ

IES-14. A furnace wall is constructed as shown in the given figure. The heat transfer coefficient across the outer casing will be:

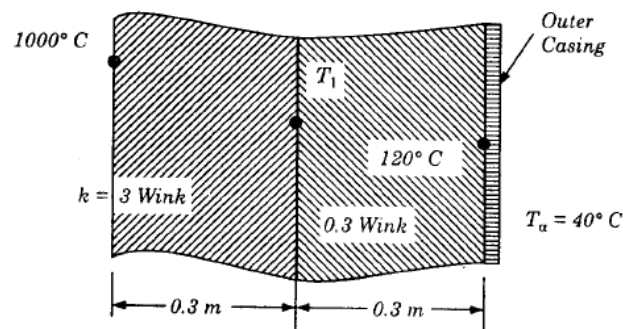

[IES-1999]

- (a)  $80 \text{ W/m}^2\text{K}$   
 (b)  $40 \text{ W/m}^2\text{K}$   
 (c)  $20 \text{ W/m}^2\text{K}$   
 (d)  $10 \text{ W/m}^2\text{K}$

IES-15. A composite wall is made of two layers of thickness  $\sigma_1$  and  $\sigma_2$  having thermal conductivities  $K$  and  $2K$  and equal surface areas normal to the direction of heat flow. The outer surfaces of the composite wall are at

# One Dimensional Steady State Conduction

## S K Mondal's

## Chapter 2

100°C and 200°C respectively. The heat transfer takes place only by conduction and the required surface temperature at the junction is 150°C [IES-2004]

What will be the ratio of their thicknesses,  $\sigma_1 : \sigma_2$ ?

- (a) 1 : 1                      (b) 2 : 1                      (c) 1 : 2                      (d) 2 : 3

IES-16. A composite plane wall is made up of two different materials of the same thickness and having thermal conductivities of  $k_1$  and  $k_2$  respectively. The equivalent thermal conductivity of the slab is:

[IES-1992; 1993; 1997; 2000]

- (a)  $k_1 + k_2$                       (b)  $k_1 k_2$                       (c)  $\frac{k_1 + k_2}{k_1 k_2}$                       (d)  $\frac{2k_1 k_2}{k_1 + k_2}$

IES-17. The equivalent thermal conductivity of the wall as shown in the figure is:

- (a)  $\frac{K_1 + K_2}{2}$                       (b)  $\frac{K_1 K_2}{K_1 + K_2}$   
 (c)  $\frac{2K_1 K_2}{K_1 + K_2}$                       (d)  $\sqrt{K_1 K_2}$

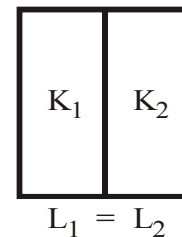

[IES-2010]

IES-18. A composite slab has two layers of different materials having internal conductivities  $k_1$  and  $k_2$ . If each layer has the same thickness, then what is the equivalent thermal conductivity of the slab? [IES-2009]

- (a)  $\frac{k_1 k_2}{(k_1 + k_2)}$                       (b)  $\frac{k_1 k_2}{2(k_1 + k_2)}$                       (c)  $\frac{2k_1}{(k_1 + k_2)}$                       (d)  $\frac{2k_1 k_2}{(k_1 + k_2)}$

IES-19. A furnace wall is constructed as shown in the figure. The interface temperature  $T_i$  will be:

- (a) 560°C                      (b) 200°C  
 (c) 920°C                      (d) 1120°C

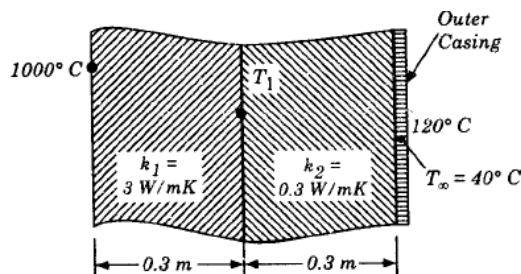

[IES-1998]

## The Overall Heat Transfer Co-efficient

IES-20. A flat plate has thickness 5 cm, thermal conductivity 1 W/(mK), convective heat transfer coefficients on its two flat faces of 10 W/(m<sup>2</sup>K) and 20 W/(m<sup>2</sup>K). The overall heat transfer co-efficient for such a flat plate is: [IES-2001]

- (a) 5 W/(m<sup>2</sup>K)                      (b) 6.33 W/(m<sup>2</sup>K)                      (c) 20 W/(m<sup>2</sup>K)                      (d) 30 W/(m<sup>2</sup>K)

IES-21. The overall heat transfer coefficient  $U$  for a plane composite wall of  $n$  layers is given by (the thickness of the  $i^{th}$  layer is  $t_i$ , thermal conductivity of the  $i^{th}$  layer is  $k_i$ , convective heat transfer co-efficient is  $h$ ) [IES-2000]

- (a)  $\frac{1}{\frac{1}{h_1} + \sum_{i=1}^n \frac{t_i}{k_i} + \frac{1}{h_n}}$                       (b)  $h_1 + \sum_{i=1}^n \frac{t_i}{k_i} + h_n$                       (c)  $\frac{1}{h_1 + \sum_{i=1}^n \frac{t_i}{k_i} + h_n}$                       (d)  $\frac{1}{h_1} + \sum_{i=1}^n \frac{t_i}{k_i} + \frac{1}{h_n}$

IES-22. A steel plate of thickness 5 cm and thermal conductivity 20 W/mK is subjected to a uniform heat flux of 800 W/m<sup>2</sup> on one surface 'A' and transfers heat by convection with a heat transfer coefficient of 80 W/m<sup>2</sup>K from the other surface 'B' into ambient air T<sub>a</sub> of 25°C. The temperature of the surface 'B' transferring heat by convection is:

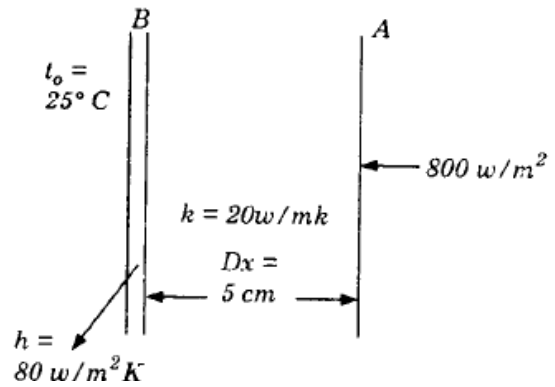

[IES-1999]

- (a) 25°C                      (b) 35°C                      (c) 45°C                      (d) 55°C

### Logarithmic Mean Area for the Hollow Cylinder

IES-23. The heat flow equation through a cylinder of inner radius “r<sub>1</sub>” and outer radius “r<sub>2</sub>” is desired in the same form as that for heat flow through a plane wall. The equivalent area A<sub>m</sub> is given by: [IES-1999]

- (a)  $\frac{A_1 + A_2}{\log_e \left( \frac{A_2}{A_1} \right)}$       (b)  $\frac{A_1 + A_2}{2 \log_e \left( \frac{A_2}{A_1} \right)}$       (c)  $\frac{A_2 - A_1}{2 \log_e \left( \frac{A_2}{A_1} \right)}$       (d)  $\frac{A_2 - A_1}{\log_e \left( \frac{A_2}{A_1} \right)}$

IES-24. The outer surface of a long cylinder is maintained at constant temperature. The cylinder does not have any heat source. [IES-2000]  
 The temperature in the cylinder will:

- (a) Increase linearly with radius                      (b) Decrease linearly with radius  
 (c) Be independent of radius                              (d) Vary logarithmically with radius

### Heat Conduction through a Composite Cylinder

IES-25. The heat flow through a composite cylinder is given by the equation: (symbols have the usual meaning) [IES-1995]

- (a)  $Q = \frac{(T_1 - T_{n+1})2\pi L}{\sum_{n=1}^{n=n} \frac{1}{K_n} \log_e \left( \frac{r_{n+1}}{r_n} \right)}$       (b)  $Q = \frac{4\pi(T_1 - T_{n+1})}{\sum_{n=1}^{n=n} \left[ \frac{r_{n+1} - r_n}{K_n r_n r_{n+1}} \right]}$   
 (c)  $Q = \frac{T_1 - T_{n+1}}{\frac{1}{A} \sum_{n=1}^{n=n} \left( \frac{L_n}{K_n} \right)}$       (d)  $Q = \frac{T_1 - T_2}{\log_e \left( \frac{r_2}{r_1} \right) \cdot 2\pi KL}$

### Heat Conduction through a Hollow Sphere

IES-26. For conduction through a spherical wall with constant thermal conductivity and with inner side temperature greater than outer wall temperature, (one dimensional heat transfer), what is the type of temperature distribution? [IES-2007]

- (a) Linear                      (b) Parabolic                      (c) Hyperbolic                      (d) None of the above

**IES-27.** What is the expression for the thermal conduction resistance to heat transfer through a hollow sphere of inner radius  $r_1$  and outer radius  $r_2$ , and thermal conductivity  $k$ ? [IES-2007]

- (a)  $\frac{(r_2 - r_1)r_1 r_2}{4\pi k}$       (b)  $\frac{4\pi k(r_2 - r_1)}{r_1 r_2}$       (c)  $\frac{r_2 - r_1}{4\pi k r_1 r_2}$       (d) None of the above

**IES-28.** A solid sphere and a hollow sphere of the same material and size are heated to the same temperature and allowed to cool in the same surroundings. If the temperature difference between the body and that of the surroundings is  $T$ , then [IES-1992]

- (a) Both spheres will cool at the same rate for small values of  $T$   
 (b) Both spheres will cool at the same reactor small values of  $T$   
 (c) The hollow sphere will cool at a faster rate for all the values of  $T$   
 (d) The solid sphere will cool a faster rate for all the values of  $T$

### Logarithmic Mean Area for the Hollow Sphere

**IES-29.** What will be the geometric radius of heat transfer for a hollow sphere of inner and outer radii  $r_1$  and  $r_2$ ? [IES-2004]

- (a)  $\sqrt{r_1 r_2}$       (b)  $r_2 r_1$       (c)  $r_2 / r_1$       (d)  $(r_2 - r_1)$

### Heat Condition through a Composite Sphere

**IES-30.** A composite hollow sphere with steady internal heating is made of 2 layers of materials of equal thickness with thermal conductivities in the ratio of 1 : 2 for inner to outer layers. Ratio of inside to outside diameter is 0.8. What is ratio of temperature drop across the inner and outer layers? [IES-2005]

- (a) 0.4      (b) 1.6      (c)  $2 \ln(0.8)$       (d) 2.5

**IES-31.** Match List-I (Governing Equations of Heat Transfer) with List-II (Specific Cases of Heat Transfer) and select the correct answer using the code given below: [IES-2005]

- | List-I  | List-II                       |
|---|-------------------------------|
| A. $\frac{d^2 T}{dr^2} + \frac{2}{r} \frac{dT}{dr} = 0$                                 | 1. Pin fin 1-D case           |
| B. $\frac{\partial^2 T}{\partial x^2} = \frac{1}{\alpha} \frac{\partial T}{\partial t}$ | 2. 1-D conduction in cylinder |
| C. $\frac{d^2 T}{dr^2} + \frac{1}{r} \frac{dT}{dr} = 0$                                 | 3. 1-D conduction in sphere   |
| D. $\frac{d^2 \theta}{dx^2} - m^2 \theta = 0$   | 4. Plane slab                 |

(Symbols have their usual meaning)

Codes:	A	B	C	D	A	B	C	D	
(a)	2	4	3	1	(b)	3	1	2	4
(c)	2	1	3	4	(d)	3	4	2	1



### **Logarithmic Mean Area for the Hollow Sphere**

- IAS-1. A hollow sphere has inner and outer surface areas of  $2 \text{ m}^2$  and  $8 \text{ m}^2$  respectively. For a given temperature difference across the surfaces, the heat flow is to be calculated considering the material of the sphere as a plane wall of the same thickness. What is the equivalent mean area normal to the direction of heat flow? [IAS-2007]
- (a)  $6 \text{ m}^2$                       (b)  $5 \text{ m}^2$                       (c)  $4 \text{ m}^2$                       (d) None of the above

**Answers with Explanation (Objective)**

**Previous 20-Years GATE Answers**

**GATE-1. Ans. (d)** One dimensional, Unsteady state, without internal heat generation

$$\frac{\partial^2 T}{\partial x^2} = \frac{1}{\alpha} \frac{\partial T}{\partial t}$$

**GATE-2. Ans. (b)**

**GATE-3. Ans. (b)**

**GATE-4. Ans. (d)**

**GATE-5. Ans. (c)**  $Q = \frac{20 + 2}{\frac{1}{20} + \frac{0.30}{20} + \frac{0.15}{50} + \frac{1}{50}} = 250$

or  $250 = \frac{20 - T}{\frac{1}{20} + \frac{0.30}{20}}$  or  $T = 3.75^\circ\text{C}$

**GATE-6. Ans. (d)**  $T_{inter} = \frac{T_1 + T_2}{2}$

Heat flow must be same (Q)  $= -k_1 A \left( \frac{T_1 - \frac{T_1 + T_2}{2}}{2b} \right) = -k_2 \left( \frac{\frac{T_1 + T_2}{2} - T_2}{b} \right)$

or  $k_1 = 2k_2$

**GATE-7. Ans. (c)** Electrical circuit

Use this formula

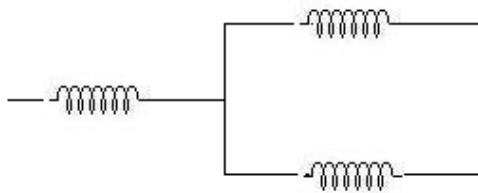

$$R_{eq} = \frac{L_1}{K_1 A_1} + \frac{1}{\frac{1}{\frac{L_2}{K_2 A_2}} + \frac{1}{\frac{L_3}{K_3 A_3}}}$$

**GATE-8. Ans. (d)** Lower the thermal conductivity greater will be the slope of the temperature distribution curve (The curve shown here is temperature distribution curve).

**GATE-9. Ans. (c)**  $Q = \frac{2\pi L(t_i - t_f)}{\frac{\ln\left(\frac{r_2}{r_1}\right)}{K_A} + \frac{\ln\left(\frac{r_3}{r_2}\right)}{K_B}} = \frac{2\pi \times 1 \times (600)}{\frac{\ln\left(\frac{0.025}{0.01}\right)}{19} + \frac{\ln\left(\frac{0.055}{0.025}\right)}{0.2}} = 944.72 \text{ W/m}$

**GATE-10. Ans. (b)**

# One Dimensional Steady State Conduction

## S K Mondal's Chapter 2

### Previous 20-Years IES Answers

IES-1. Ans. (c)  $R = \frac{L}{KA} = \frac{0.6}{0.4 \times 1.5} = 1 \text{ K/W}$

IES-2. Ans. (a)  $\frac{Q_1}{Q_2} = \frac{K_1 A \frac{dT}{dx}}{K_2 A \frac{dT}{dx}}$

IES-3. Ans. (a)  $\frac{K_1 A (\Delta T_1)}{dx} = \frac{K_2 A (\Delta T_2)}{dx}$   
 $\Rightarrow K_1 (\Delta T_1) = K_2 (\Delta T_2) \Rightarrow \frac{\Delta T_1}{\Delta T_2} = \frac{K_2}{K_1} = \frac{2}{3}$

IES-4. Ans. (b)  $\frac{k_A (1325 - 1200)}{x_A} = \frac{k_B (1200 - 25)}{x_B}$   
 $\Rightarrow \frac{x_A}{x_B} = \frac{2 \times 125}{1175} = 0.2127 \approx 0.213$

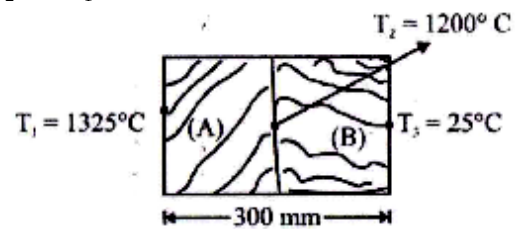

IES-5. Ans. (b)  $\dot{q} = K \frac{dT}{dx}$  or  $k = \left(\frac{dT}{dx}\right) = \left(\frac{10}{0.1}\right) = 0.3 \text{ W/mK}$

IES-6. Ans. (c)  $K_{average} = \frac{25 + 15}{2} = 20$  [As it is varying linearly]

IES-7. Ans. (b)  $\therefore \dot{Q} = kA \frac{dT}{dx}$   
 or  $\frac{6000}{10 \times 60} = 100 \times \left(\frac{10}{10000}\right) \times \frac{dT}{1}$   
 or  $dT = 100^\circ\text{C}$

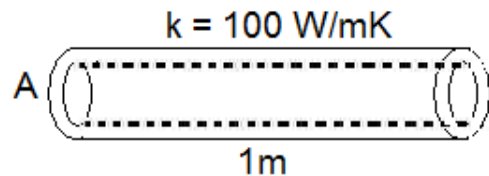

IES-8. Ans. (b)  $Q = -KA \frac{dT}{dx} \Rightarrow \frac{Q}{A} = -K \frac{dT}{dx}$   
 $\Rightarrow 25 \times 10^3 = 50 \times \frac{(100 - T_2)}{(0.1)} \Rightarrow T_2 = 50^\circ\text{C}$

IES-9. Ans. (a) For the shape of temperature profile.  
 $K = k_o(1 + \alpha T)$

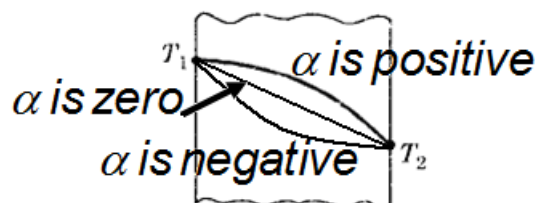

IES-10. Ans. (d) Use  $\frac{d^2T}{dx^2} = \frac{1}{\alpha} \frac{dT}{dx}$  relation.

Temperature distribution is  $T = 3x^2 + 3x + 16$ ,  $\frac{dT}{dx} = 6x + 3^\circ\text{K/cm}^2$

IES-11. Ans. (d)  $Q = \frac{t_f - t_i}{\sum \frac{L}{KA}} = \frac{1840 - 340}{\frac{0.3}{0.6 \times 1} + \frac{0.2}{0.4 \times 1} + \frac{0.1}{0.1 \times 1}} = 750 \text{ W}$

IES-12. Ans. (b)  $K_1 \Delta T_1 = K_2 \Delta T_2 = K_3 \Delta T_3 = Q$

$$\Rightarrow \Delta T_1 : \Delta T_2 : \Delta T_3 = \frac{Q}{K_1} : \frac{Q}{K_2} : \frac{Q}{K_3} = \frac{1}{1} : \frac{1}{2} : \frac{1}{4} = 4 : 2 : 1$$

**IES-13. Ans. (c)** Heat Loss / sec =  $\frac{(T_1 - T_2)}{\frac{1}{h_1 A} + \frac{x}{K_1 A} + \frac{1}{h_2 A}} = \frac{(30 - 10)}{\frac{1}{40} \left( \frac{0.115}{1.15} + \frac{1}{2.5} + \frac{1}{4} \right)}$

$$= \frac{40 \times 20}{(0.1 + 0.4 + 0.25)} = 1066.66 \text{ kJ/sec} = \frac{3840.000}{1000} \text{ kJ/hour} = 3840 \text{ kJ/hour}$$

**IES-14. Ans. (d)** For two insulating layers,

$$\frac{Q}{A} = \frac{t_1 - t_2}{\frac{\Delta x_1}{k_1} + \frac{\Delta x_2}{k_2}} = \frac{1000 - 120}{\frac{0.3}{3} + \frac{0.3}{0.3}} = \frac{880}{1.1} = 800$$

For outer casing,  $\frac{Q}{A} = \frac{120 - 40}{1/h}$ , or  $800 \times \frac{1}{h}$ , and  $h = \frac{800}{80} = 10 \text{ W/m}^2\text{K}$

**IES-15. Ans. (c)**  $Q_{AB} = Q_{BC}$

$$\text{or } -k_1 A \left( \frac{200 - 150}{\delta_1} \right) = -2k_2 A \left( \frac{150 - 100}{\delta_2} \right)$$

$$\text{or } \frac{\delta_1}{\delta_2} = \frac{50}{2 \times 50} = \frac{1}{2}$$

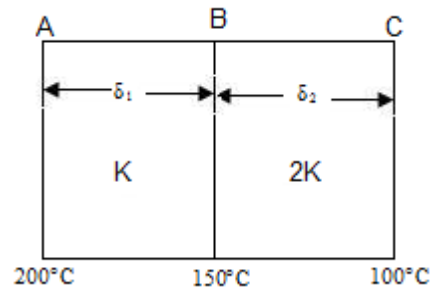

**IES-16. Ans. (d)** The common mistake student do is they take length of equivalent conductor as  $L$  but it must be  $2L$ . Then equate the thermal resistance of them.

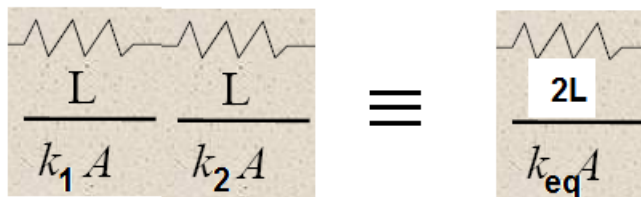
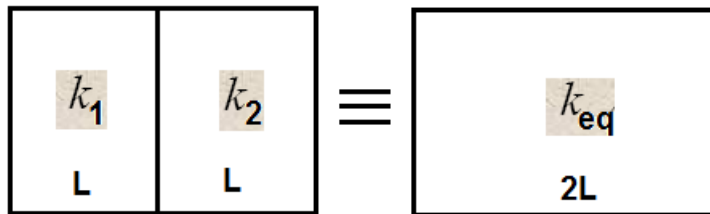

**IES-17. Ans. (c)**  $\frac{1}{K_{eq}} = \frac{1}{2} \left( \frac{1}{K_1} + \frac{1}{K_2} \right)$

$$K_{eq} = \frac{2K_1 K_2}{K_1 + K_2}$$

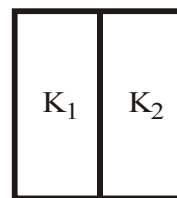

$$L_1 = L_2$$

**IES-18. Ans. (d)** Same questions [IES-1997] and [IES-2000]

**IES-19. Ans. (c)** For two insulating layers,  $\frac{Q}{A} = \frac{t_1 - t_2}{\frac{\Delta x_1}{k_1} + \frac{\Delta x_2}{k_2}} = \frac{1000 - 120}{\frac{0.3}{3} + \frac{0.3}{0.3}} = 800$

Considering first layer,  $\frac{Q}{A} = \frac{1000 - T_i}{\frac{0.3}{3}} = 800$ , or  $T_i = 1000 - 80 = 920^\circ\text{C}$

**One Dimensional Steady State Conduction**  
**S K Mondal's** **Chapter 2**

IES-20. Ans. (a)

IES-21. Ans. (a)

IES-22. Ans. (b)  $800 = \frac{t_B - t_o}{1/h} = \frac{t_B - 25}{1/80}$

IES-23. Ans. (d)

IES-24. Ans. (d)

IES-25. Ans. (a)

IES-26. Ans. (c) Temp distribution would be  $\frac{t - t_1}{t_2 - t_1} = \frac{\frac{1}{r} - \frac{1}{r_1}}{\frac{1}{r_2} - \frac{1}{r_1}}$

IES-27. Ans. (c) Resistance  $(R) = \frac{r_2 - r_1}{4\pi k(r_1 r_2)} \therefore Q = \frac{\Delta t}{R} = \frac{4\pi k(t_1 - t_2)}{\left(\frac{r_2 - r_1}{r_1 r_2}\right)}$

IES-28. Ans. (c)

IES-29. Ans. (a)

IES-30. Ans. (d)  $r_i = 0.8 r_o$  and  $r = r_i + t = r_2 - t$

$$\begin{aligned} \Rightarrow 2r &= r_i + r_o \Rightarrow r = \frac{r_i + r_o}{2} \\ \Rightarrow r &= \frac{r_i + 1.25r_i}{2} = 1.125r_i \\ \Rightarrow r &= \frac{0.8r_o + r_o}{2} = 0.9r_o \Rightarrow \frac{r_o}{r} = \frac{1}{0.9} \\ \therefore Q &= \frac{t_i - t}{\frac{r - r_i}{4\pi k r r_i}} = \frac{t - t_o}{\frac{r_o - r}{4\pi (2k) r r_o}} \end{aligned}$$

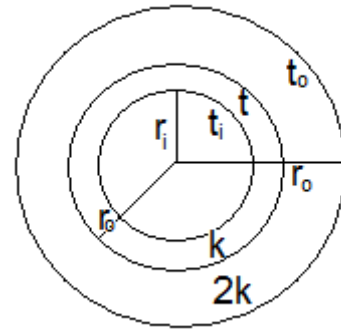

IES-31. Ans. (d)

**Previous 20-Years IAS Answers**

IAS-1. Ans. (c)  $A_m = \sqrt{A_1 A_2} = \sqrt{2 \times 8} = 4 \text{ m}^2$



### 3. Critical Thickness of Insulation

#### Theory at a Glance (For IES, GATE, PSU)

#### Critical Thickness of Insulation

[IES-05]

- Note: When the total thermal resistance is made of conductive thermal resistance ( $R_{\text{cond.}}$ ) and convective thermal resistance ( $R_{\text{conv.}}$ ), the addition of insulation in some cases, May reduces the convective thermal resistance due to increase in surface area, as in the case of cylinder and sphere, and the total thermal resistance may actually decreases resulting in increased heat flow.

Critical thickness: the thickness up to which heat flow increases and after which heat flow decreases is termed as critical thickness.

$$\text{Critical thickness} = (r_c - r_1)$$

**For Cylinder:**

$$r_c = \frac{k}{h}$$

**For Sphere:**

$$r_c = \frac{2k}{h}$$

Common Error: In the examination hall student's often get confused about  $\frac{h}{k}$  or  $\frac{k}{h}$

A little consideration can remove this problem, Unit of  $\frac{k}{h}$  is  $\frac{W / mK}{W / m^2K} = m$

• For cylinder –

$$Q = \frac{2\pi L(t_1 - t_{air})}{\frac{\ln(r_2/r_1)}{k} + \frac{1}{hr_2}}$$

$$\text{For } Q_{\max} \Rightarrow \frac{\ln(r_2/r_1)}{k} + \frac{1}{hr_2}$$

is minimum

$$\therefore \frac{d}{dr_2} \left[ \frac{\ln(r_2/r_1)}{k} + \frac{1}{hr_2} \right] = 0$$

$$\therefore \frac{1}{k} \times \frac{1}{r_2} + \frac{1}{h} \times \left( -\frac{1}{r_2^2} \right) = 0 \quad \therefore r_2 = \frac{k}{h}$$

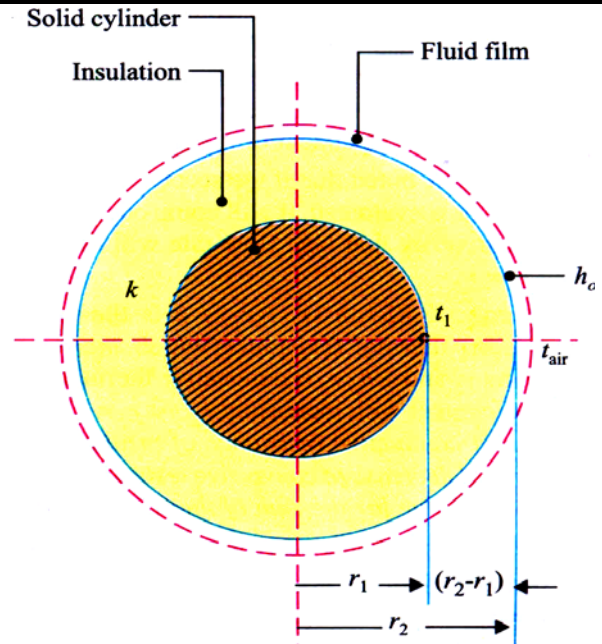

Critical Thickness of Insulation for Cylinder

• For Sphere,  $Q = \frac{4\pi(t_1 - t_{air})}{\frac{r_2 - r_1}{kr_1 r_2} + \frac{1}{hr_2^2}}$

$$\therefore \frac{d}{dr_2} \left( \frac{r_2 - r_1}{kr_1 r_2} + \frac{1}{hr_2^2} \right) = 0 \text{ gives}$$

$$r_2 = \frac{2k}{h}$$

- (i) For cylindrical bodies with  $r_1 < r_c$ , the heat transfer increase by adding insulation till  $r_2 = r_1$  as shown in Figure below (a). If insulation thickness is further increased, the rate of heat loss will decrease from this peak value, but until a certain amount of insulation denoted by  $r_2'$  at  $b$  is added, the heat loss rate is still greater for the solid cylinder. This happens when  $r_1$  is small and  $r_c$  is large, viz., the thermal conductivity of the insulation  $k$  is high (poor insulation material) and  $h_o$  is low. **A practical application would be the insulation of electric cables which should be a good insulator for current but poor for heat.**
- (ii) For cylindrical bodies with  $r_1 > r_c$ , the heat transfer decrease by adding insulation (Figure below) this happens when  $r_1$  is large and  $r_2$  is small, viz., a good insulation material is used with low  $k$  and  $h_o$  is high. In *stream and refrigeration pipes* heat insulation is the main objective. For insulation to be properly effective in restricting heat transmission, the *outer radius must be greater than or equal to the critical radius.*

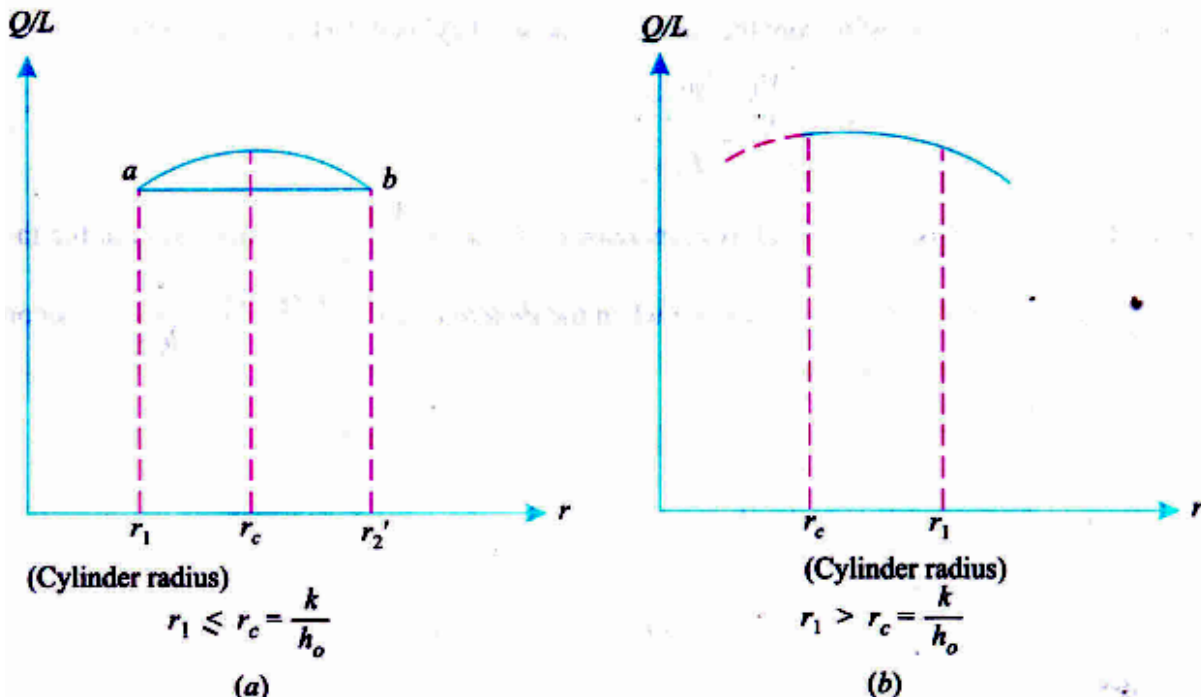

Minimum  $q$  at  $r_o = (k/h) = r_{cr}$  (critical radius)

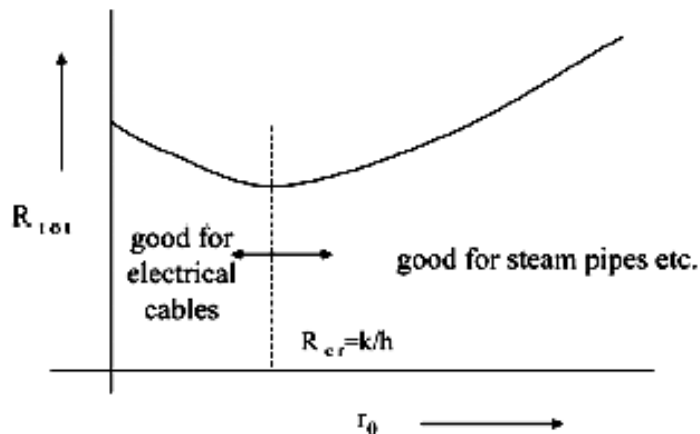

**For two layer insulation**

Inner layer will be made by **lower conductivity** materials. And outer layer will be made by **higher conductive** materials.

- A. **For electrical insulation:** i.e. for electric cable main object is heat dissipation; Not heat insulation, Insulation will be effective if  $r_c > r_1$ . In this case if we add insulation it will increase heat transfer rate.
- B. **For thermal insulation:** i.e. for thermal insulation main object is to reduction of heat transfer; Insulation will be effective if  $r_c \ll r_1$ . In this case if we add insulation it will reduce heat transfer rate.
- C. Plane wall critical thickness of insulation is **zero**. If we add insulation it will reduce heat loss.



Heat Conduction with Internal Heat Generation

Volumetric heat generation,  $(\dot{q}_g) = \text{W/m}^3$

Unit of  $\dot{q}_g$  is  $\text{W/m}^3$  but in some problem we will find that unit is  $\text{W/m}^2$ . In this case they assume that the thickness of the material is one metre. If the thickness is  $L$  meter then volumetric heat generation is  $(\dot{q}_g) \text{ W/m}^3$  but total heat generation is  $\dot{q}_g L \text{ W/m}^2$  surface area.

Plane Wall with Uniform Heat Generation

Equation: For a small strip of  $dx$  (shown in figure below)

$$Q_x + Q_g = Q_{(x+dx)}$$

$$\therefore Q_x + Q_g = Q_x + \frac{d}{dx}(Q_x) dx$$

$$\therefore Q_g = \frac{d}{dx}(Q_x) dx$$

$$\therefore \dot{q}_g A dx = \frac{d}{dx}(Q_x) dx$$

That given

$$\frac{d^2t}{dx^2} + \frac{\dot{q}_g}{k} = 0 \quad \text{---(i)}$$

For any problem integrate this Equation and use boundary condition

$$\frac{dt}{dx} + \frac{\dot{q}_g}{k} x = c_1 \quad \text{---(ii)}$$

$$\text{or } t + \frac{\dot{q}_g x^2}{2k} = c_1 x + c_2 \quad \text{---(iii)}$$

Use boundary condition and find  $C_1$  &  $C_2$  than proceed.

$$\text{For } Q_x = -kA \left( \frac{dt}{dx} \right)_{at x}$$

$$\therefore Q_0 = -kA \left( \frac{dt}{dx} \right)_{x=0},$$

$$Q_L = -kA \left( \frac{dt}{dx} \right)_{x=L}$$

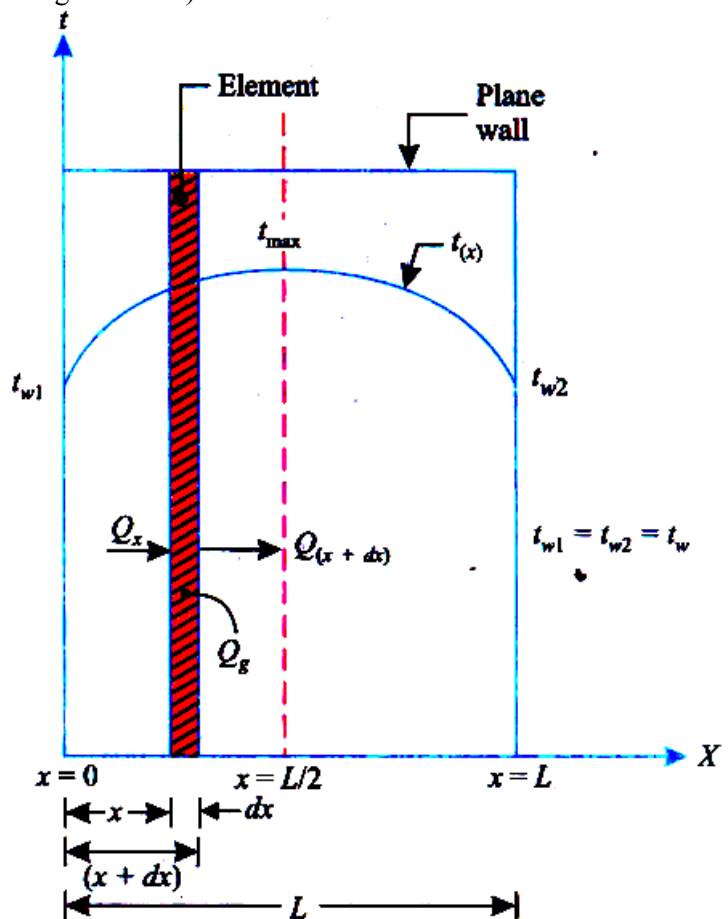

Heat Conduction with Internal Heat Generation

For objective :

Maximum temperature,  $t_{\max} = \frac{\dot{q}_g L^2}{8k} + t_{\text{wall}}$  (If both wall temperature,  $t_{\text{wall}}$ )

### Current Carrying Electrical Conductor

$$Q_g = \dot{q}_g AL = I^2 R = I^2 \frac{\rho L}{A}$$

$$J = \frac{I}{A} = \text{current density (amp./m}^2\text{)}$$

$$\therefore \dot{q}_g = \frac{I^2}{A^2} \times \rho = J^2 \cdot \rho$$

Where,

$I$  = Current flowing in the conductor,

$R$  = Electrical resistance,

$\rho$  = Specific resistance of resistivity,

$L$  = Length of the conductor, and

$A$  = Area of cross-section of the conductor.

### If One Surface Insulated

Then  $\left(\frac{dt}{dx}\right)_{x=0}$  will be = 0

i.e. use end conditions

(i)  $\left(\frac{dt}{dx}\right)_{x=0} = 0$

(ii) At  $x = L, t = t_L$

Maximum temperature will occur at  $x = 0$ ,

But start from that first Equation,

$$\frac{d^2 t}{dx^2} + \frac{\dot{q}_g}{k} = 0$$

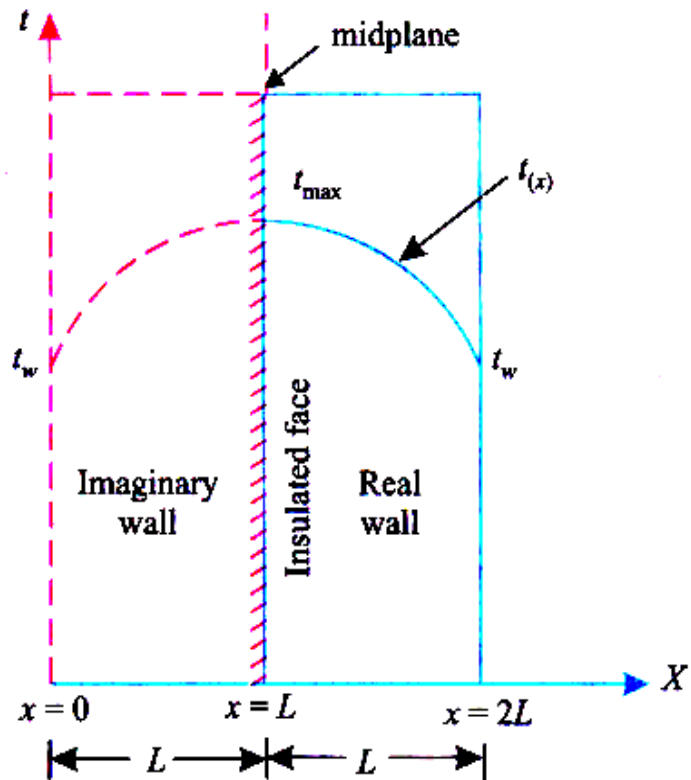

If one surface insulated

**Maximum Temperature (Remember)**

$$t_{\max} = \frac{\dot{q}_g L^2}{8k} + t_w \quad \text{For plate both wall temperature}(t_w); \text{ at centre of plate, } x = \frac{L}{2}$$

$$t_{\max} = \frac{\dot{q}_g R^2}{4k} + t_w \quad \text{For cylinder, at centre, } (r = 0)$$

$$t_{\max} = \frac{\dot{q}_g R^2}{6k} + t_w \quad \text{For sphere, at centre, } (r = 0)$$

**Starting Formula (Remember)**

$$\frac{d^2 t}{dx^2} + \frac{\dot{q}_g}{k} = 0 \quad \text{For Plate}$$

$$\frac{d}{dr} \left( r \frac{dt}{dr} \right) + \frac{\dot{q}_g}{k} \cdot r = 0 \quad \text{For cylinder}$$

$$\frac{d}{dr} \left( r^2 \frac{dt}{dr} \right) + \frac{\dot{q}_g}{k} \cdot r^2 = 0 \quad \text{For Sphere}$$

**Temperature Distribution – with Heat Generation**

(a) For both sphere and cylinder

$$\frac{t - t_w}{t_{\max} - t_w} = \left[ 1 - \left( \frac{r}{R} \right)^2 \right]$$

(b) Without heat generation

(i) For **plane**,  $\frac{t - t_1}{t_2 - t_1} = \frac{x}{L}$

(ii) For **cylinder**,  $\frac{t - t_1}{t_2 - t_1} = \frac{\ln(r/r_1)}{\ln(r_2/r_1)}$

(iii) For **sphere**,  $\frac{t - t_1}{t_2 - t_1} = \frac{\frac{1}{r} - \frac{1}{r_1}}{\frac{1}{r_2} - \frac{1}{r_1}}$

**Dielectric Heating**

Dielectric heating is a method of quickly heating insulating materials packed between the plates (of an electric condenser) to which a high frequency, high voltage alternating current is applied.

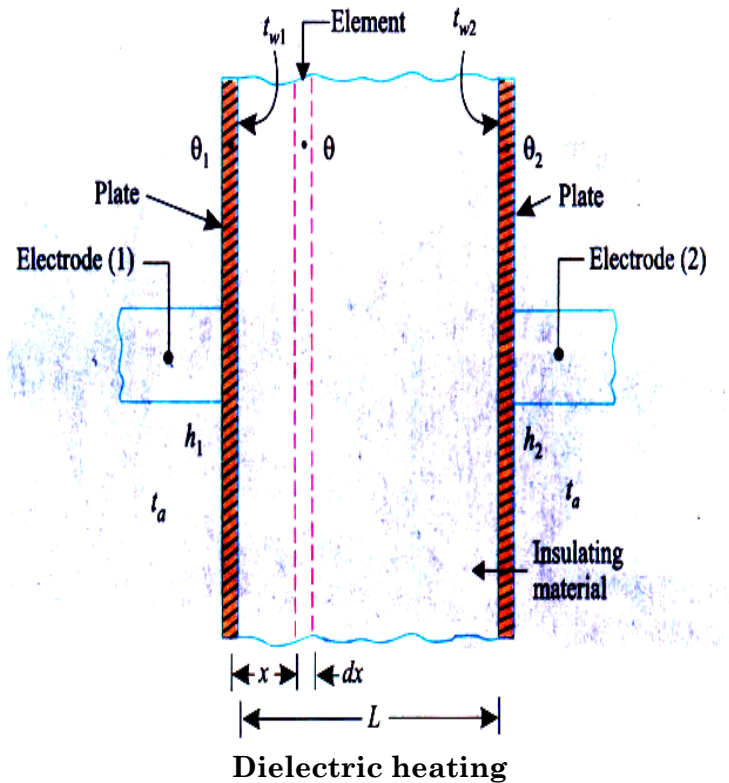

Where  $\theta_1 = (t_{w1} - t_a)$  temperature of electrode (1) above surroundings.  $\theta_2 = (t_{w2} - t_a)$  temperature of electrode (2) above surroundings.

If we use  $\theta$  form then it will be easy to find out solution. That so why we are using the following equation in  $\theta$  form

$$\frac{d^2\theta}{dx^2} + \frac{\dot{q}_g}{k} = 0$$

$$\therefore \theta + \frac{\dot{q}_g}{k} \cdot \frac{x^2}{2} = c_1x + c_2$$

Using boundary condition  $x = 0, \theta = \theta_1; -kA \left( \frac{d\theta}{dx} \right)_{x=0} = h_1A(t_{w1} - t_a)$

$$\theta = \theta_1 + \frac{h_1\theta_1}{k} - \frac{\dot{q}_g}{k} \cdot \frac{x^2}{2}$$

$$\therefore \theta_2 = \theta_1 + \frac{h_1\theta_1}{k} - \frac{\dot{q}_g}{k} \cdot \frac{L^2}{2} \dots (i) [\because \text{at } x = L, \theta = \theta_2]$$

(but don't use it as a boundary condition)

And Heat generated within insulating material = Surface heat loss from both electrode:

Cylinder with Uniform Heat Generation

For Solid cylinder one boundary condition

$$\left(\frac{dt}{dr}\right)_{r=0} = 0$$

(as maximum temperature)

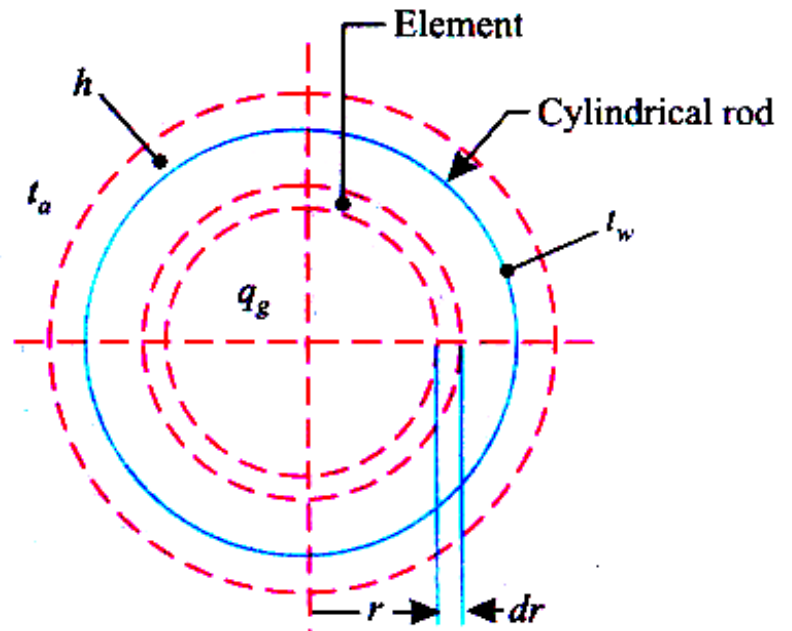

Solid Cylinder with Heat generation

For Hollow Cylinder with Insulation

$$\left(\frac{dt}{dr}\right)_{r=r_1} = 0$$

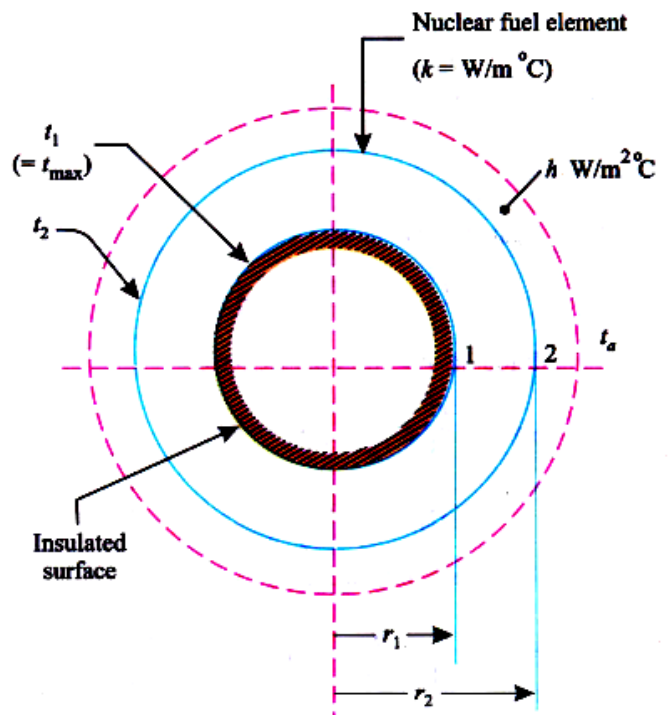

### Heat Transfer through Piston Crown

Here heat generating,  $(\dot{q}_g) = \text{W/m}^2$   
 (Note unit)

$$Q_r = -k 2\pi r b \frac{dt}{dr}, \quad Q_g = \dot{q}_g \times 2\pi r dr$$

$$\therefore Q_g = \frac{d}{dr}(Q_r) dr$$

$$\text{that gives, } \frac{d}{dr}\left(r \frac{dt}{dr}\right) + \frac{\dot{q}_g}{kb} \cdot r = 0$$

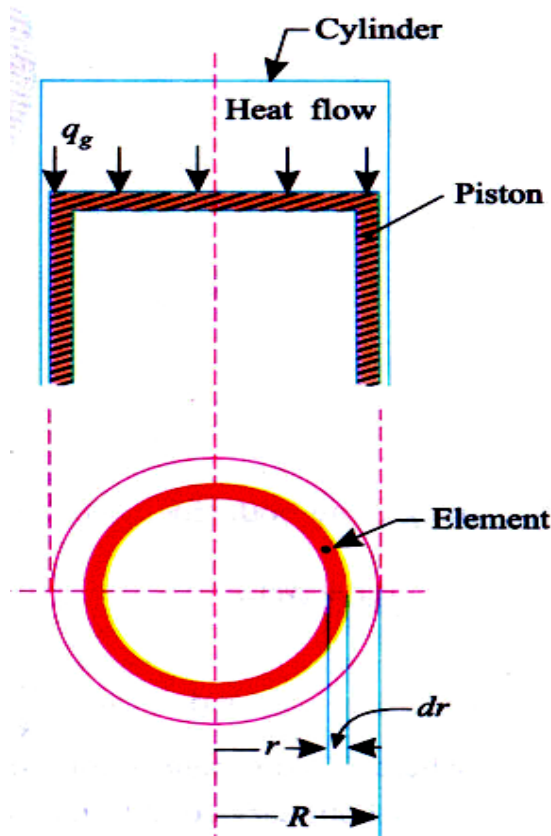

Heat transfer through piston crown

### Heat conduction with Heat Generation in the Nuclear Cylindrical Fuel Rod

Here heat generation rate  $\dot{q}_g(r)$

$$\dot{q}_g = \dot{q}_0 \left[ 1 - \left( \frac{r}{R_{fr}} \right)^2 \right]$$

$$\text{then use, } \frac{d}{dr}\left(r \frac{dt}{dr}\right) + \frac{\dot{q}_g}{k} \cdot r = 0$$

Where,  $\dot{q}_g$  = Heat generation rate at radius  $r$ .  
 $\dot{q}_0$  = Heat generation rate at the centre of the rod ( $r = 0$ ). And  
 $R_{fr}$  = Outer radius of the fuel rod.

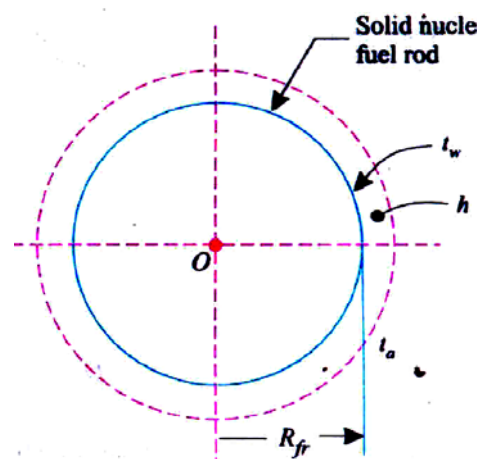

Nuclear Cylinder Fuel Rod

Nuclear Cylinder Fuel Rod with 'Cladding' i.e. Rod covered with protective materials known as 'Cladding'.

## OBJECTIVE QUESTIONS (GATE, IES, IAS)

## Previous 20-Years GATE Questions

**Critical Thickness of Insulation**

- GATE-1.** A steel steam pipe 10 cm inner diameter and 11 cm outer diameter is covered with insulation having the thermal conductivity of 1 W/mK. If the convective heat transfer coefficient between the surface of insulation and the surrounding air is 8 W / m<sup>2</sup>K, then critical radius of insulation is: [GATE-2000]  
 (a) 10 cm                      (b) 11 cm                      (c) 12.5 cm                      (d) 15 cm
- GATE-2.** It is proposed to coat a 1 mm diameter wire with enamel paint ( $k = 0.1$  W/mK) to increase heat transfer with air. If the air side heat transfer coefficient is 100 W/m<sup>2</sup>K, then optimum thickness of enamel paint should be: [GATE-1999]  
 (a) 0.25 mm                      (b) 0.5 mm                      (c) 1 mm                      (d) 2 mm
- GATE-3.** For a current wire of 20 mm diameter exposed to air ( $h = 20$  W/m<sup>2</sup>K), maximum heat dissipation occurs when thickness of insulation ( $k = 0.5$  W/mK) is: [GATE-1993; 1996]  
 (a) 20 mm                      (b) 25 mm                      (c) 20 mm                      (d) 10 mm

**Heat Conduction with Heat Generation in the Nuclear Cylindrical Fuel Rod**

- GATE-4.** Two rods, one of length  $L$  and the other of length  $2L$  are made of the same material and have the same diameter. The two ends of the longer rod are maintained at 100°C. One end of the shorter rod is maintained at 100°C while the other end is insulated. Both the rods are exposed to the same environment at 40°C. The temperature at the insulated end of the shorter rod is measured to be 55°C. The temperature at the mid-point of the longer rod would be: [GATE-1992]  
 (a) 40°C                      (b) 50°C                      (c) 55°C                      (d) 100°C

## Previous 20-Years IES Questions

**Critical Thickness of Insulation**

- IES-1.** Upto the critical radius of insulation: [IES-1993; 2005]  
 (a) Added insulation increases heat loss  
 (b) Added insulation decreases heat loss  
 (c) Convection heat loss is less than conduction heat loss  
 (d) Heat flux decreases
- IES-2.** Upto the critical radius of insulation [IES-2010]  
 (a) Convection heat loss will be less than conduction heat loss  
 (b) Heat flux will decrease

- (c) Added insulation will increase heat loss
- (d) Added insulation will decrease heat loss

**IES-3.** The value of thermal conductivity of thermal insulation applied to a hollow spherical vessel containing very hot material is  $0.5 \text{ W/mK}$ . The convective heat transfer coefficient at the outer surface of insulation is  $10 \text{ W/m}^2\text{K}$ .

What is the critical radius of the sphere? [IES-2008]

- (a)  $0.1 \text{ m}$
- (b)  $0.2 \text{ m}$
- (c)  $1.0 \text{ m}$
- (d)  $2.0 \text{ m}$

**IES-4.** A hollow pipe of  $1 \text{ cm}$  outer diameter is to be insulated by thick cylindrical insulation having thermal conductivity  $1 \text{ W/mK}$ . The surface heat transfer coefficient on the insulation surface is  $5 \text{ W/m}^2\text{K}$ . What is the minimum effective thickness of insulation for causing the reduction in heat leakage from the insulated pipe? [IES-2004]

- (a)  $10 \text{ cm}$
- (b)  $15 \text{ cm}$
- (c)  $19.5 \text{ cm}$
- (d)  $20 \text{ cm}$

**IES-5.** A metal rod of  $2 \text{ cm}$  diameter has a conductivity of  $40 \text{ W/mK}$ , which is to be insulated with an insulating material of conductivity of  $0.1 \text{ W/m K}$ . If the convective heat transfer coefficient with the ambient atmosphere is  $5 \text{ W/m}^2\text{K}$ , the critical thickness of insulation will be: [IES-2001; 2003]

- (a)  $1 \text{ cm}$
- (b)  $2 \text{ cm}$
- (c)  $7 \text{ cm}$
- (d)  $8 \text{ cm}$

**IES-6.** A copper wire of radius  $0.5 \text{ mm}$  is insulated with a sheathing of thickness  $1 \text{ mm}$  having a thermal conductivity of  $0.5 \text{ W/m - K}$ . The outside surface convective heat transfer coefficient is  $10 \text{ W/m}^2 - \text{K}$ . If the thickness of insulation sheathing is raised by  $10 \text{ mm}$ , then the electrical current-carrying capacity of the wire will: [IES-2000]

- (a) Increase
- (b) Decrease
- (c) Remain the same
- (d) Vary depending upon the electrical conductivity of the wire

**IES-7.** In current carrying conductors, if the radius of the conductor is less than the critical radius, then addition of electrical insulation is desirable, as [IES-1995]

- (a) It reduces the heat loss from the conductor and thereby enables the conductor to carry a higher current.
- (b) It increases the heat loss from the conductor and thereby enables the conductor to carry a higher current.
- (c) It increases the thermal resistance of the insulation and thereby enables the conductor to carry a higher current.
- (d) It reduces the thermal resistance of the insulation and thereby enables the conductor to carry a higher current.

**IES-8.** It is desired to increase the heat dissipation rate over the surface of an electronic device of spherical shape of  $5 \text{ mm}$  radius exposed to convection with  $h = 10 \text{ W/m}^2\text{K}$  by encasing it in a spherical sheath of conductivity  $0.04 \text{ W/mK}$ , For maximum heat flow, the diameter of the sheath should be: [IES-1996]

- (a)  $18 \text{ mm}$
- (b)  $16 \text{ mm}$
- (c)  $12 \text{ mm}$
- (d)  $8 \text{ mm}$

**IES-9.** What is the critical radius of insulation for a sphere equal to? [IES-2008]  
 $k = \text{thermal conductivity in W/m-K}$



$h$  = heat transfer coefficient in  $W/m^2K$

- (a)  $2kh$                       (b)  $2k/h$                       (c)  $k/h$                       (d)  $\sqrt{2kh}$

**IES-10. Assertion (A): Addition of insulation to the inside surface of a pipe always reduces heat transfer rate and critical radius concept has no significance. [IES-1995]**

**Reason (R): If insulation is added to the inside surface, both surface resistance and internal resistance increase.**

- (a) Both A and R are individually true and R is the correct explanation of A  
 (b) Both A and R are individually true but R is **not** the correct explanation of A  
 (c) A is true but R is false  
 (d) A is false but R is true

**IES-11. Match List-I (Parameter) with List-II (Definition) and select the correct answer using the codes given below the lists: [IES-1995]**

**List-I**

- A. Time constant of a thermometer of radius  $r_o$   
 B. Biot number for a sphere of radius  $r_o$   
 C. Critical thickness of insulation for a wire of radius  $r_o$   
 D. Nusselt number for a sphere of radius  $r_o$

**List-II**

1.  $hr_o/k_{fluid}$   
 2.  $k/h$   
 3.  $hr_o/k_{solid}$   
 4.  $h_o\pi r_o l / \rho c V$

**Nomenclature:**  $h$ : Film heat transfer coefficient,  $k_{solid}$ : Thermal conductivity of solid,  $k_{fluid}$ : Thermal conductivity of fluid,  $\rho$ : Density,  $c$ : Specific heat,  $V$ : Volume,  $l$ : Length.

- |               |          |          |          |          |          |          |          |          |
|---------------|----------|----------|----------|----------|----------|----------|----------|----------|
| <b>Codes:</b> | <b>A</b> | <b>B</b> | <b>C</b> | <b>D</b> | <b>A</b> | <b>B</b> | <b>C</b> | <b>D</b> |
| (a)           | 4        | 3        | 2        | 1        | (b)      | 1        | 2        | 3        |
| (c)           | 2        | 3        | 4        | 1        | (d)      | 4        | 1        | 2        |

**IES-12. An electric cable of aluminium conductor ( $k = 240 W/mK$ ) is to be insulated with rubber ( $k = 0.15 W/mK$ ). The cable is to be located in air ( $h = 6W/m^2$ ). The critical thickness of insulation will be: [IES-1992]**

- (a) 25mm                      (b) 40 mm                      (c) 160 mm                      (d) 800 mm

**IES-13. Consider the following statements: [IES-1996]**

1. Under certain conditions, an increase in thickness of insulation may increase the heat loss from a heated pipe.
2. The heat loss from an insulated pipe reaches a maximum when the outside radius of insulation is equal to the ratio of thermal conductivity to the surface coefficient.
3. Small diameter tubes are invariably insulated.
4. Economic insulation is based on minimum heat loss from pipe.

**Of these statements**

- (a) 1 and 3 are correct                      (b) 2 and 4 are correct  
 (c) 1 and 2 are correct                      (d) 3 and 4 are correct.

**IES-14. A steam pipe is to be lined with two layers of insulating materials of different thermal conductivities. For minimum heat transfer**

- (a) The better insulation must be put inside                      [IES-1992; 1994; 1997]  
 (b) The better insulation must be put outside  
 (c) One could place either insulation on either side  
 (d) One should take into account the steam temperature before deciding as to which insulation is put where.

**Heat Conduction with Internal Heat Generation**

IES-15. Water jacketed copper rod “ $D$ ” m in diameter is used to carry the current. The water, which flows continuously maintains the rod temperature at  $T_i^{\circ}C$  during normal operation at “ $I$ ” amps. The electrical resistance of the rod is known to be “ $R$ ”  $\Omega/m$ . If the coolant water ceased to be available and the heat removal diminished greatly, the rod would eventually melt. What is the time required for melting to occur if the melting point of the rod material is  $T_{mp}$ ? [IES-1995]  
 [ $C_p$  = specific heat,  $\rho$  = density of the rod material and  $L$  is the length of the rod]

(a)  $\frac{\rho(\pi D^2 / 4)C_p (T_{mp} - T_i)}{I^2 R}$       (b)  $\frac{(T_{mp} - T_i)}{\rho I^2 R}$       (c)  $\frac{\rho(T_{mp} - T_i)}{I^2}$       (d)  $\frac{C_p (T_{mp} - T_i)}{I^2 R}$

**Plane Wall with Uniform Heat Generation**

IES-16. A plane wall of thickness  $2L$  has a uniform volumetric heat source  $q^*$  ( $W/m^3$ ). It is exposed to local ambient temperature  $T_{\infty}$  at both the ends ( $x = \pm L$ ). The surface temperature  $T_s$  of the wall under steady-state condition (where  $h$  and  $k$  have their usual meanings) is given by:

[IES-2001]

(a)  $T_s = T_{\infty} + \frac{q^* L}{h}$       (b)  $T_s = T_{\infty} + \frac{q^* L^2}{2k}$       (c)  $T_s = T_{\infty} + \frac{q^* L^2}{h}$       (d)  $T_s = T_{\infty} + \frac{q^* L^3}{2k}$

IES-17. The temperature variation in a large plate, as shown in the given figure, would correspond to which of the following condition (s)?

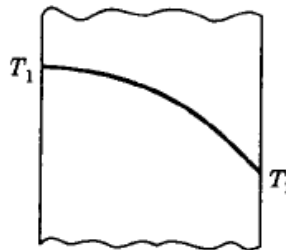

1. Unsteady heat
2. Steady-state with variation of  $k$
3. Steady-state with heat generation

Select the correct answer using the codes given below: [IES-1998]

Codes: (a) 2 alone      (b) 1 and 2      (c) 1 and 3      (d) 1, 2 and 3

IES-18. In a long cylindrical rod of radius  $R$  and a surface heat flux of  $q_0$  the uniform internal heat generation rate is: [IES-1998]

(a)  $\frac{2q_0}{R}$       (b)  $2q_0$       (c)  $\frac{q_0}{R}$       (d)  $\frac{q_0}{R^2}$

Previous 20-Years IAS Questions

**Critical Thickness of Insulation**

IAS-1. In order to substantially reduce leakage of heat from atmosphere into cold refrigerant flowing in small diameter copper tubes in a refrigerant system, the radial thickness of insulation, cylindrically wrapped around the tubes, must be: [IAS-2007]

- (a) Higher than critical radius of insulation

- (b) Slightly lower than critical radius of insulation
- (c) Equal to the critical radius of insulation
- (d) Considerably higher than critical radius of insulation

**IAS-2. A copper pipe carrying refrigerant at  $-200\text{ C}$  is covered by cylindrical insulation of thermal conductivity  $0.5\text{ W/m K}$ . The surface heat transfer coefficient over the insulation is  $50\text{ W/m}^2\text{ K}$ . The critical thickness of the insulation would be:**

**[IAS-2001]**

- (a) 0.01 m                      (b) 0.02 m                      (c) 0.1 m                      (d) 0.15 m

**Answers with Explanation (Objective)**

**Previous 20-Years GATE Answers**

**GATE-1. Ans. (c)** Critical radius of insulation ( $r_c$ ) =  $\frac{k}{h} = \frac{1}{8} \text{ m} = 12.5 \text{ cm}$

**GATE-2. Ans. (b)** Critical radius of insulation ( $r_c$ ) =  $\frac{k}{h} = \frac{0.1}{100} \text{ m} = 1 \text{ mm}$

$\therefore$  Critical thickness of enamel point =  $r_c - r_i = 1 - \frac{1}{2} = 0.5 \text{ mm}$

**GATE-3. Ans. (b)** Maximum heat dissipation occurs when thickness of insulation is critical.

Critical radius of insulation ( $r_c$ ) =  $\frac{k}{h} = \frac{0.5}{20} \text{ m} = 25 \text{ mm}$

Therefore thickness of insulation =  $r_c - r_i = 25 - \frac{20}{2} = 15 \text{ mm}$

**GATE-4. Ans. (c)**

**Previous 20-Years IES Answers**

**IES-1. Ans. (a)**

**IES-2. Ans. (c)** The thickness upto which heat flow increases and after which heat flow decreases is termed as Critical thickness. In case of cylinders and spheres it is called 'Critical radius'.

**IES-3. Ans. (a)** Minimum  $q$  at  $r_o = (k/h) = r_{cr}$  (critical radius)

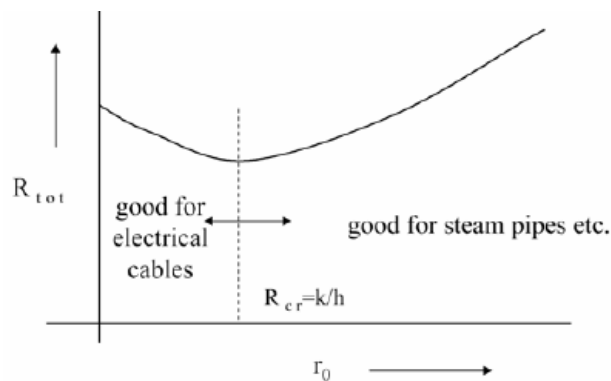

**IES-4. Ans. (c)** Critical radius of insulation ( $r_c$ ) =  $\frac{k}{h} = \frac{1}{5} = 0.2 \text{ m} = 20 \text{ cm}$

$\therefore$  Critical thickness of insulation ( $\Delta r$ )<sub>C</sub> =  $r_c - r_i = 20 - 0.5 = 19.5 \text{ cm}$

**IES-5. Ans. (a)** Critical radius of insulation ( $r_c$ ) =  $\frac{K}{h} = \frac{0.1}{5} = 0.02 \text{ m} = 2 \text{ cm}$

Critical thickness of insulation ( $t$ ) =  $r_c - r_i = 2 - 1 = 1 \text{ cm}$

**IES-6. Ans. (a)**

**IES-7. Ans. (b)**

**IES-8. Ans. (b)** The critical radius of insulation for ensuring maximum heat transfer by

conduction ( $r$ ) =  $\frac{2k}{h} = \frac{2 \times 0.04}{10} \text{ m} = 8 \text{ mm}$ . Therefore diameter should be 16 mm.

**IES-9. Ans. (b)** Critical radius of insulation for sphere is  $\frac{2k}{h}$  and for cylinder is  $k/h$

**IES-10. Ans. (a)** A and R are correct. R is right reason for A.

**IES-11. Ans. (a)**

**IES-12. Ans. (a)**

**IES-13. Ans. (c)**

**IES-14. Ans. (a)** For minimum heat transfer, the better insulation must be put inside.

**IES-15. Ans. (a)**

**IES-16. Ans. (a)**

**IES-17. Ans. (a)**

**IES-18. Ans. (a)**

### Previous 20-Years IAS Answers

**IAS-1. Ans. (d)** At critical radius of insulation heat leakage is maximum if we add more insulation then heat leakage will reduce.

**IAS-2. Ans. (a)** Critical radius of insulation  $(r_c) = \frac{k}{h} = \frac{0.5}{50} \text{ m} = 0.01 \text{ m}$

4.

# Heat Transfer from Extended Surfaces (Fins)

## Theory at a Glance (For IES, GATE, PSU)

**Convection:** Heat transfer between a solid surface and a moving fluid is governed by the Newton's cooling law:  $q = hA (T_s - T_\infty)$  Therefore, to increase the convective heat transfer, One can.

- Increase the temperature difference  $(T_s - T_\infty)$  between the surface and the fluid.
- Increase the convection coefficient  $h$ . This can be accomplished by increasing the fluid flow over the surface since  $h$  is a function of the flow velocity and the higher the velocity,
- The higher the  $h$ . Example: a cooling fan.
- Increase the contact surface area  $A$ . Example: a heat sink with fins.

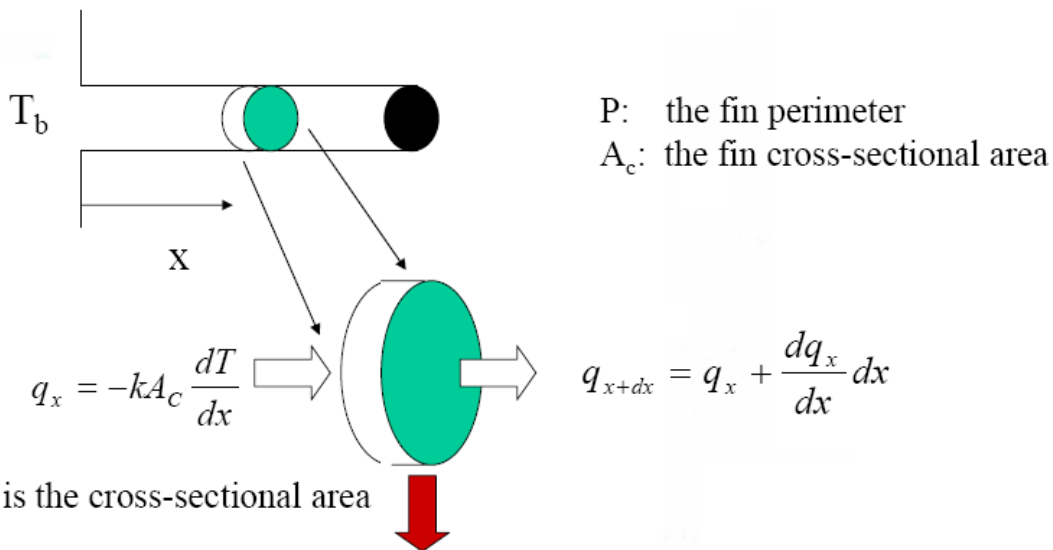

$$q_x = -kA_c \frac{dT}{dx}$$

$$q_{x+dx} = q_x + \frac{dq_x}{dx} dx$$

$A_c$  is the cross-sectional area

$$dq_{conv} = h(dA_s)(T - T_\infty), \text{ where } dA_s \text{ is the surface area of the element}$$

$$dq_{conv} = h(dA_s)(T - T_\infty), \text{ Where } dA_s \text{ is the surface area of the element}$$

$$\frac{d^2T}{dx^2} - \frac{hP}{kA_c}(T - T_\infty) = 0, \text{ A second - order, ordinary differential equation}$$

Define a new variable  $\theta(x) = T(x) - T_\infty$ , so that

$$\frac{d^2\theta}{dx^2} - m^2\theta = 0, \text{ Where } m^2 = \frac{hP}{kA_c} \quad \text{or} \quad (D^2 - m^2)\theta = 0$$

Characteristics equation with two real roots:  $+m$  &  $-m$

The general solution is of the form

$$\theta(x) = C_1 e^{mx} + C_2 e^{-mx}$$

# Heat Transfer from Extended Surfaces (Fins)

**S K Mondal's****Chapter 4**

To evaluate the two constants  $C_1$  and  $C_2$ , we need to specify two boundary conditions:  
 The first one is obvious: the base temperature is known as  $T(0) = T_b$   
 The second condition will depend on the end condition of the tip.

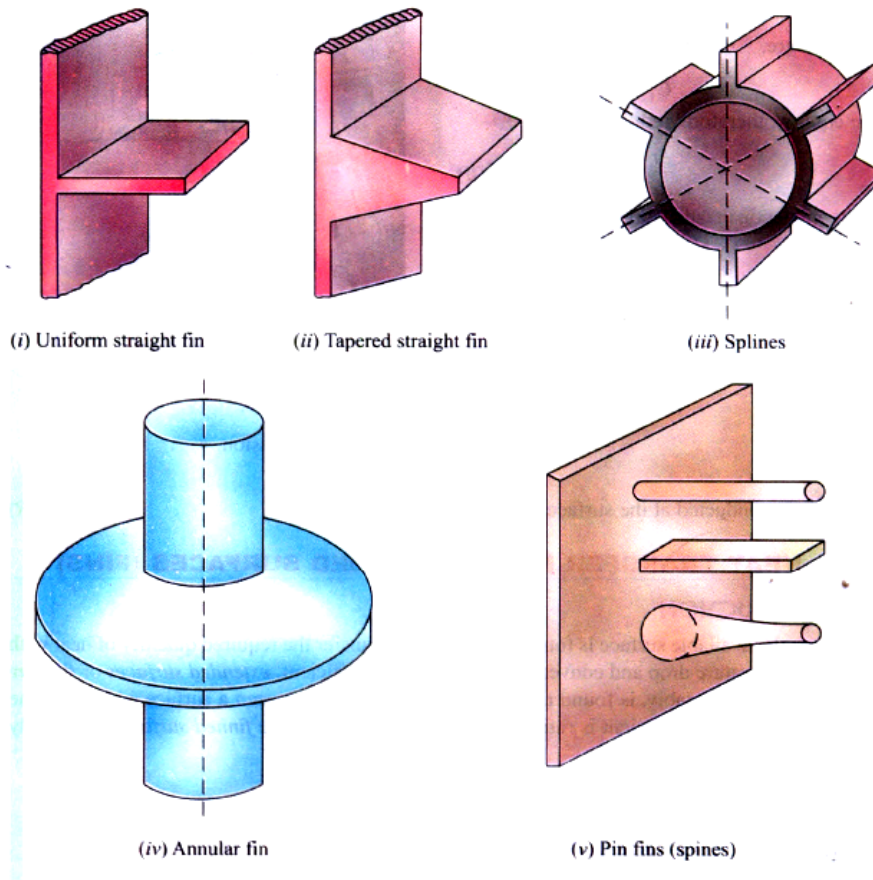

**Common type of configuration of FINS**

## Heat Flow through “Rectangular Fin”

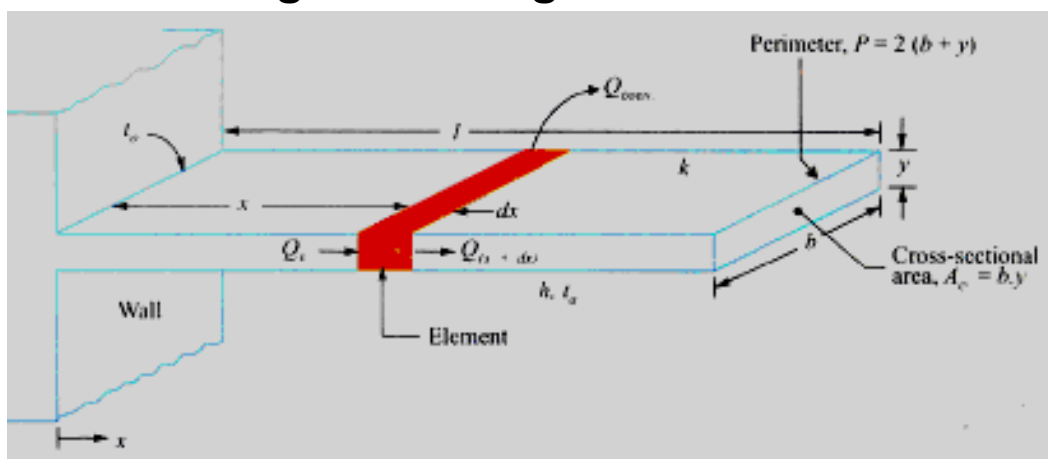

### Heat Flow through a Rectangular Fin

- Let,  $l$  = Length of the fin (perpendicular to surface from which heat is to be removed).
- $b$  = Width of the fin (parallel to the surface from which heat is to be removed).
- $y$  = Thickness of the fin.
- $p$  = Perimeter of the fin  $= 2(b + y)$ .
- $A_c$  = Area of cross-section  $(b.y)$

$t_o$  = Temperature at the base of the fin. And

$t_a$  = Temperature of the ambient/surrounding fluid.

$k$  = Thermal conductivity (constant). And

$h$  = Heat transfer coefficient (convective).

$$Q_x = -kA_c \left( \frac{dT}{dx} \right)$$

$$Q_{x+dx} = -Q_x + \frac{\partial}{\partial x} [Q_x] dx$$

$$Q_{cov} = h(P \cdot dx)(t - t_a)$$

$$kA_c \left[ \frac{d^2T}{dx^2} \right] dx - h(Pdx)(t - t_a) = 0$$

$$\frac{d^2T}{dx^2} - \frac{hP}{kA_c} (t - t_a) = 0$$

Temperature excess,  $\theta = t - t_a$

$$\frac{d\theta}{dx} = \frac{dt}{dx}$$

$$\frac{d^2\theta}{dx^2} - m^2\theta = 0 \quad \text{or} \quad m = \sqrt{\frac{hP}{kA_c}}$$

### Heat Dissipation from an Infinitely Long Fin ( $\ell \rightarrow \infty$ ):

$$\frac{d^2\theta}{dx^2} - m^2\theta = 0$$

at  $x = 0$ ,  $t = t_o$  i.e.  $\theta = \theta_o$

at  $x = \infty$ ,  $t = t_a$  i.e.  $\theta = 0$

$$\theta = C_1 e^{mx} + C_2 e^{-mx}$$

$$\theta_o = C_1 + C_2$$

$$0 = C_1 \cdot e^{m(\infty)} + C_2 \cdot e^{-\infty m} \therefore C_1 = 0$$

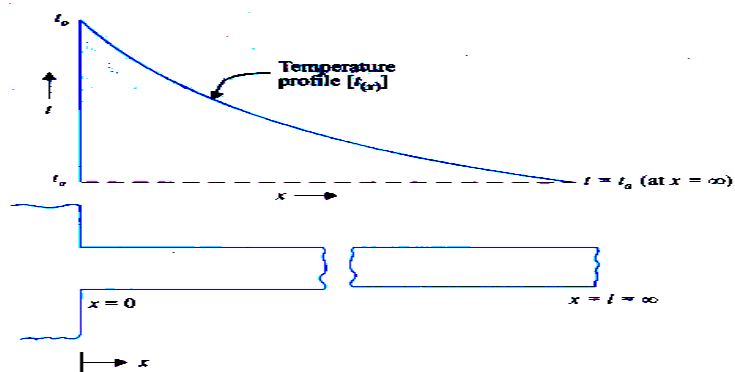



**Temperature Distribution**

$$\theta = \theta_0 e^{-mx}$$

or  $\frac{\theta}{\theta_0} = e^{-mx}$

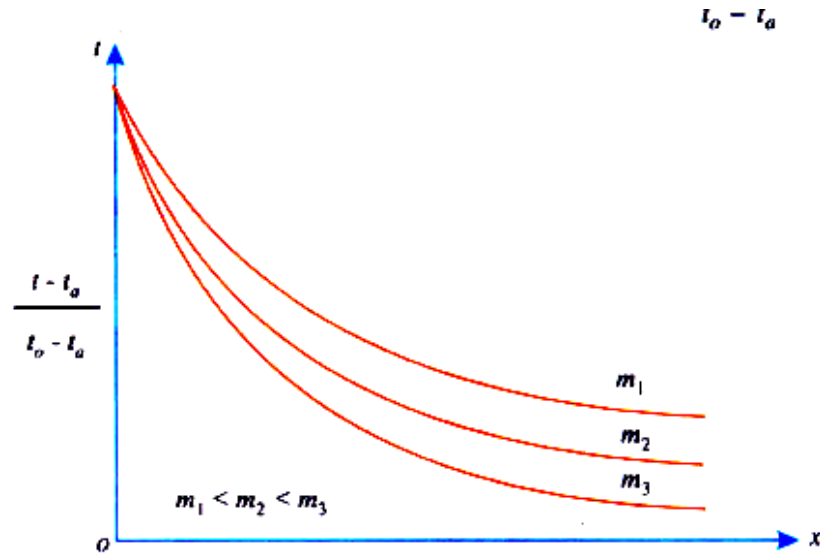

**Temperature Distribution**

- (a) By considering the heat flow across the root or base by conduction.
- (b) By considering the heat which is transmitted by convection from the surface.

**(a) By considering the heat flow across the root or base by conduction**

$$Q_{fin} = -kA_c \left( \frac{dt}{dx} \right)_{at x=0}$$

$$\frac{t - t_a}{t_0 - t_a} = e^{-mx} \quad \Rightarrow \quad t - t_a = (t_0 - t_a) e^{-mx}$$

$$\left( \frac{dt}{dx} \right)_{x=0} = -m(t_0 - t_a) e^{-mx}$$

$$Q_{fin} = k A_c m(t_0 - t_a) = k A_c \sqrt{\frac{hP}{k A_c}} \cdot \theta_0$$

$$\Rightarrow \boxed{Q_{fin} = \sqrt{hP k A_c} \times \theta_0}$$

**(b) By considering the heat which is transmitted by convection from the surface**

$$Q_{fin} = \int_0^{\infty} h P dx (t - t_a) = \int_0^{\infty} h P (t_0 - t_a) e^{-mx} dx$$

$$\Rightarrow Q_{fin} = h P (t_0 - t_a) \frac{1}{m} = \sqrt{hP k A_c} \cdot \theta_0$$

**Heat Dissipation from a Fin Insulated at the Tip:**

At  $x=0, \theta = \theta_0$  & at  $x=l, \frac{dt}{dx} = 0$

$c_1 + c_2 = \theta_0$

$\theta = c_1 e^{mx} + c_2 e^{-mx}$

or  $t - t_a = c_1 e^{mx} + c_2 e^{-mx} = mc_1 e^{mx} - mc_2 e^{-mx}$

$0 = c_1 e^{ml} - c_2 e^{-ml}$

$\frac{\theta}{\theta_0} = \frac{\cosh\{m(l-x)\}}{\cosh(ml)}$

$Q_{fin} = -kA_c \left[ \frac{dt}{dx} \right]_{x=0}$

$Q_{fin} = kA_c m(t_0 - t_a) \tanh(ml)$

$\therefore Q_{fin} = \sqrt{hPkA_c} \times \theta_0 \tanh(ml)$

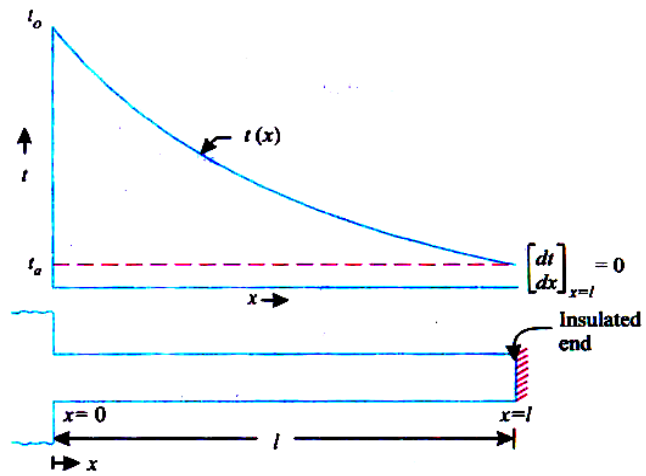

Heat dissipation from a fin insulated at the tip

**Heat Dissipation from a Fin Losing Heat at the Tip**

At  $x=0, \theta = \theta_0$  and  $x = l$

$-k A_c \left( \frac{dt}{dx} \right)_{x=l} = h A_c (t - t_a); \quad \frac{dt}{dx} = -\frac{h\theta}{k}$  at  $x = l$

$\frac{\theta}{\theta_0} = \frac{t - t_a}{t_0 - t_a} = \frac{\cosh[m(l-x)] + \frac{h}{km} [\sinh\{m(l-x)\}]}{\cosh(ml) + \frac{h}{km} [\sinh(ml)]}$

$Q_{fin} = \sqrt{hPkA_c} \cdot \theta_0 \cdot \left[ \frac{\tanh h(ml) + \frac{h}{km}}{1 + \frac{h}{km} \tanh h(ml)} \right]$

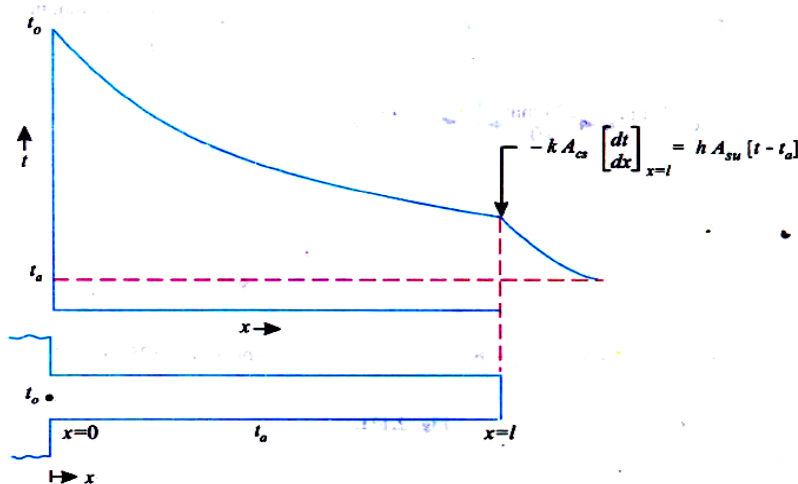

Heat dissipation from a fin losing heat at the tip

**Temperature Distribution for Fins Different Configurations**

Case	Tip Condition	Temp. Distribution	Fin heart transfer
A	Convection heat transfer: $h\theta(L) = -k(d\theta/dx)_{x=L}$	$\frac{\cosh m(L-x) + \left(\frac{h}{mk}\right) \sinh m(L-x)}{\cosh mL + \left(\frac{h}{mk}\right) \sinh mL}$	$M\theta_o \frac{\sinh mL + \left(\frac{h}{mk}\right) \cosh mL}{\cosh mL + \left(\frac{h}{mk}\right) \sinh mL}$
B	Adiabatic $(d\theta/dx)_{x=L} = 0$	$\frac{\cosh m(L-x)}{\cosh mL}$	$M\theta_o \tanh mL$
C	Given temperature: $\theta(L) = \theta_L$	$\frac{\frac{\theta_L}{\theta_b} \sinh m(L-x) + \sinh m(L-x)}{\sinh mL}$	$M\theta_o \frac{\left(\cosh mL - \frac{\theta_L}{\theta_b}\right)}{\sinh mL}$
D	Infinitely long fin $\theta(L) = 0$	$e^{-mx}$	$M\theta_o$

$$\theta = T - T_\infty, m^2 = \frac{hP}{kA_c}$$

$$\theta_b = \theta(0) = T_b - T_\infty, M = \sqrt{hPkA_c} \theta_b$$

### Correction Length

- **The correction length can be determined by using the formula:**

$L_c = L + (A_c/P)$ , where  $A_c$  is the cross-sectional area and  $P$  is the Perimeter of the fin at the tip.

- **Thin rectangular fin:**  $A_c = Wt, P = 2(W+t) \approx 2W$ , since  $t \ll W$

$$L_c = L + (A_c/P) = L + (Wt/2W) = L + (t/2)$$

- **Cylindrical fin:**  $A_c = (\pi/4)D^2, P = \pi D, L_c = L + (A_c/P) = L + (D/4)$

- **Square fin:**  $A_c = W^2, P = 4W$ ,

$$L_c = L + (A_c/P) = L + (W^2/4W) = L + (W/4).$$

### Fin with Internal Heat Generation — Straight Fin

$$\frac{d^2\theta}{dx^2} - m^2\theta + \frac{\dot{q}_g}{k} = 0$$

$$\therefore \theta = C_1 \cosh(mx) + C_2 \sinh(mx) + \frac{\dot{q}_g}{km^2}$$

Then use boundary condition.

**Composite Fin; No Temperature Gradient Along the Radial Direction**

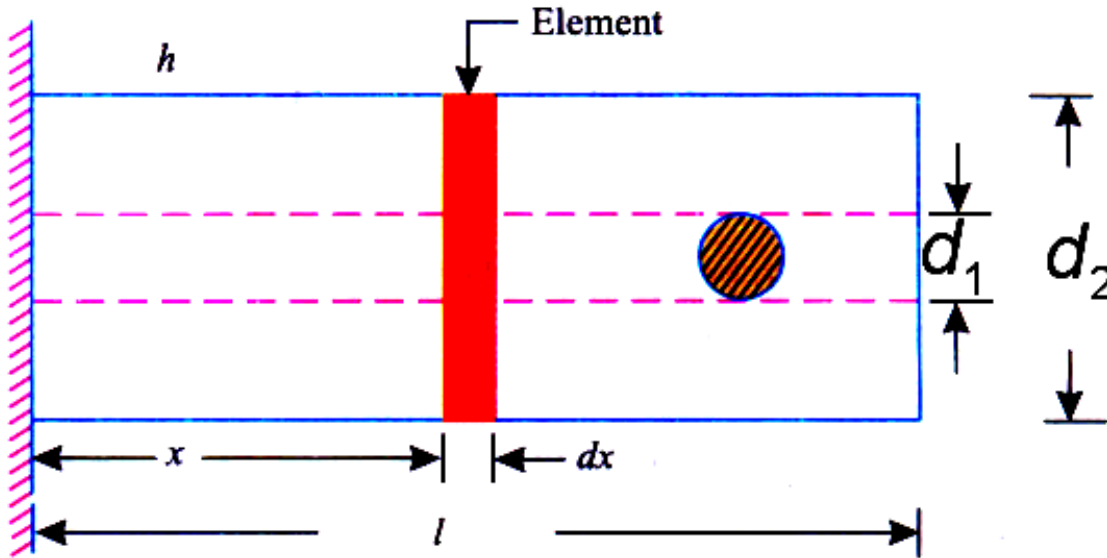

As no temperature Gradient along the radial direction

$$\begin{aligned} \therefore Q_x &= -(A_i k_i + A_o k_o) \frac{d\theta}{dx} \\ Q_o &= h P dx \cdot \theta \\ \therefore -\frac{\partial}{\partial x}(\theta_x) dx &= Q_c \\ \therefore \frac{d^2 \theta}{dx^2} - \left( \frac{h P}{k_i A_i + k_o A_o} \right) \cdot \theta &= 0 \\ \therefore m &= \sqrt{\frac{h P}{k_i A_i + k_o A_o}} \end{aligned}$$

**Efficiency and Effectiveness of Fin**

$$\text{Efficiency of fin } (\eta_{fin}) = \frac{\text{Actual heat transferred by the fin } (Q_{fin})}{\text{Maximum heat that would be transferred if whole surface of the fin maintained at the base temperature } (Q_{max})}$$

$$\text{Effectiveness of fin } (\varepsilon_{fin}) = \frac{\text{Heat loss with fin}}{\text{Heat loss without fin}}$$

i) For infinitely long fin,  $(\eta_{fin}) = \frac{1}{m\ell}$

- ii) For insulated tip fin,  $(\eta_{fin}) = \frac{\tanh(ml)}{ml}$
- iii) For infinitely long fin,  $(\epsilon_{fin}) = \sqrt{\frac{kP}{hA_c}}$
- iv) For insulated tip fin,  $(\epsilon_{fin}) = \sqrt{\frac{kP}{hA_c}} \times \tanh(ml)$

**Thermal Resistance Concept:**

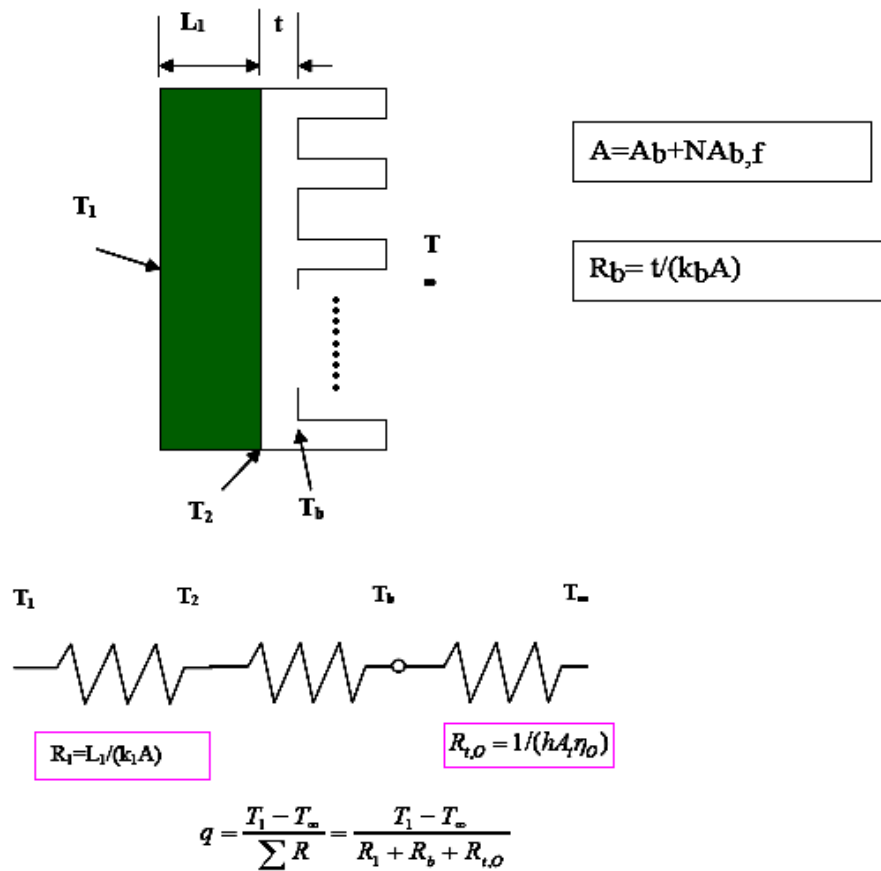

Thermal resistance concepts for fin

**Effectiveness,  $(\epsilon_{fin})$**

$$\epsilon_{fin} = \frac{Q_{with\ fin}}{Q_{without\ fin}} = \sqrt{\frac{kP}{hA_c}} = \frac{\sqrt{hPkA_c} (t_0 - t_a)}{hA_c (t_0 - t_a)}$$

If the ratio  $\frac{P}{A_c}$  is  $\uparrow$   $\epsilon_{fin}$   $\uparrow$

- (1) Due to this reason, thin and closely spaced fins are preferred, but **boundary layer** is the limitation.

(ii) Use of fin is only recommended if  $\ell$  is small. Boiling, condensation, high velocity fluid etc, **No use of fin.**

(iii)  $k \uparrow \quad \varepsilon \uparrow$  so use copper, aluminium etc.

$$\varepsilon_{\text{fin}} = \eta_{\text{fin}} \times \frac{\text{Surface area of the fin}}{\text{Cross-section area of the fin}}$$

### Biot Number

$$B_i = \frac{\text{Internal resistance of fin material} \left( \frac{\delta}{k} \right)}{\text{External resistance of fluid on the fin surface} \left( \frac{1}{h} \right)} = \frac{h\delta}{k} \quad \left[ \text{Note: where, } \delta = \frac{y}{2} \right]$$

If  $B_i < 1$                       then  $\varepsilon > 1 \rightarrow$  in this condition only use fin.  
 If  $B_i = 1$                       then  $\varepsilon = 1 \rightarrow$  No improvement with fin.  
 If  $B_i > 1$                       then  $\varepsilon < 1 \rightarrow$  Fin reduced heat transfer.

### Don't use fin: when?

When value of h is large:      (i) Boiling.  
   (ii) Condensation.  
   (iii) High velocity fluid.

The fin of a finite length also loss heat by tip by convection. We may use for that fin the formula of insulated tip if

Corrected length,  $\left[ l_c = l + \frac{y}{2} \right]$       (VIMP for objective Question)

#### Design of Rectangular fin

- (i) For insulated tip,  $\frac{l}{y} = \frac{0.7095}{\sqrt{B_i}}$
- (ii) For real fin, (loss head by tip also)  $B_i = 1$

### The Conditions for Fins to be Effective are:

- (i) Thermal conductivity (k) should be large.
- (ii) Heat transfer co-efficient (h) should be small.
- (iii) Thickness of the fin (y) should be small.

$\Rightarrow$  The straight fins can be of rectangular, triangular, and parabolic profiles; **parabolic fins are the most effective but are difficult to manufacture.**

- To increase  $\epsilon_f$ , the fin's material should have **higher thermal conductivity,  $k$** .
- It seems to be counterintuitive that the **lower convection coefficient,  $h$** , the higher  $\epsilon_f$ . But it is not because if  $h$  is very high, it is not necessary to enhance heat transfer by adding heat fins. Therefore, heat fins are more effective if  $h$  is low. Observation: If fins are to be used on surfaces separating gas and liquid. Fins are usually placed on the gas side. (Why?)
- $P/A_c$  should be as high as possible. Use a square fin with a dimension of  $W$  by  $W$  as an example:  $P = 4W$ ,  $A_c = W^2$ ,  $P/A_c = (4/W)$ . The smaller  $W$ , the higher the  $P/A_c$ , and the higher  $\epsilon_f$ .
- **Conclusion:** It is preferred to use thin and closely spaced (to increase the total number) fins.

The effectiveness of a fin can also be characterized as

$$\epsilon_f = \frac{q_f}{q} = \frac{q_f}{hA_c(T_b - T_\infty)} = \frac{(T_b - T_\infty) / R_{tf}}{(T_b - T_\infty) / R_{th}} = \frac{R_{th}}{R_{tf}}$$

It is a ratio of the thermal resistance due to convection to the thermal resistance of a fin. In order to enhance heat transfer, the fin's resistance should be lower than that of the resistance due only to convection.

## Estimation of Error in Temperature Measurement in a Thermometer Well

1. Thermometric error =  $\frac{t_l - t_f}{t_o - t_f}$
2. Error in temperature in measurement =  $(t_l - t_f)$

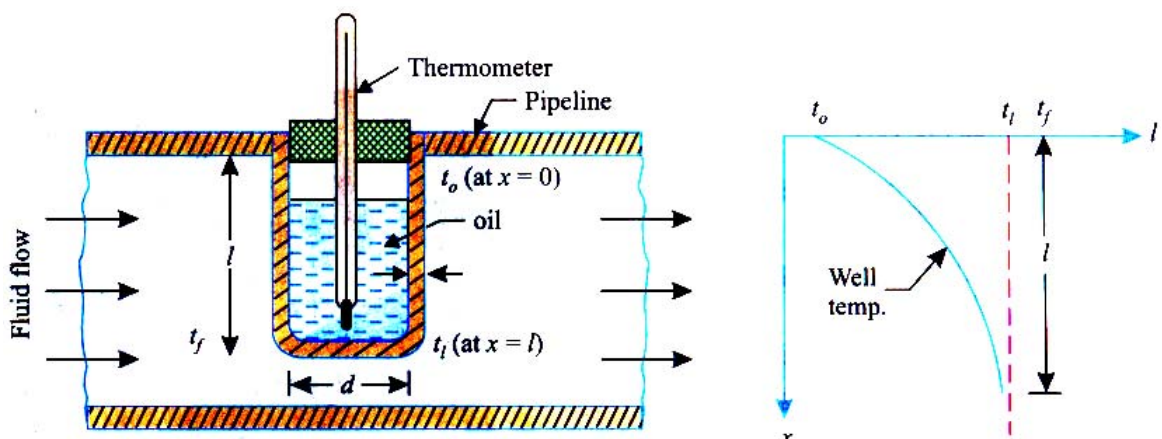

**Estimate of error in Temperature Measurement in a thermometer well**

Assume No heat flow in tip i.e. **Insulated tip formula.**

$$\therefore \frac{\theta_x}{\theta_o} = \frac{\cosh\{m(\ell - x)\}}{\cosh(m\ell)}$$

At  $x = \ell$        $\frac{\theta_1}{\theta_o} = \frac{t_\ell - t_f}{t_o - t_f} = \frac{1}{\cosh(m\ell)} = \text{Thermometric error}$

**Note (I):** If only wall thickness  $\delta$  is given then

$$P = \pi(d_i + 2\delta) \approx \pi d_i$$

$$A_{cs} = \pi d_i \delta$$

$$\therefore m = \sqrt{\frac{hP}{kA_c}} = \sqrt{\frac{h \times \pi d_i}{k \times \pi d_i \delta}} = \sqrt{\frac{h}{k\delta}}$$

(ii) If (a)  $d_i$  &  $\delta$  given                      or (b)  $d_o$  &  $\delta$  given then

or (c)  $d_i$  &  $\delta$  given                      where       $P = \text{Actual} = \pi d_o$ ;       $A = \frac{\pi(d_o^2 - d_i^2)}{4}$

**Heat Transfer from a Bar Connected to the Two Heat Sources at Different, Temperatures**

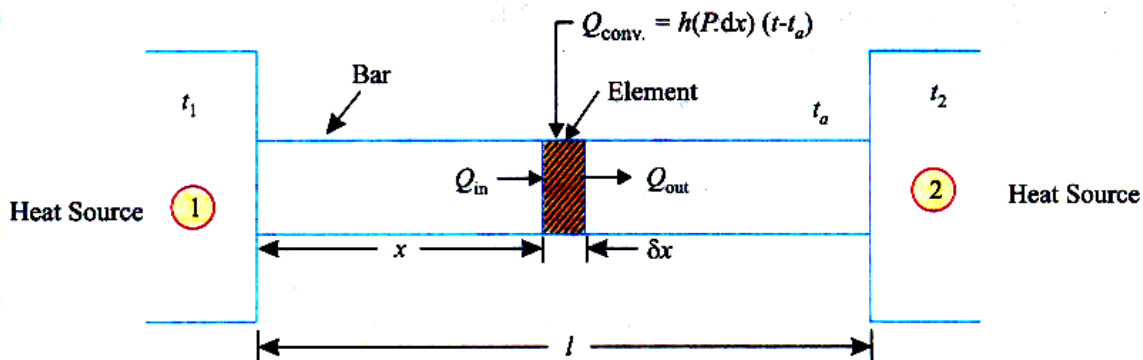

**Heat Transfer from a Bar connected between two sources of different temperature**

(i) Same fin equation       $\frac{d^2\theta}{dx^2} - m^2\theta = 0$

(ii) Boundary condition (1) at  $x = 0$        $\theta = \theta_1$   
 at  $x = \ell$        $\theta = \theta_2$

(iii)       $\theta = \frac{\theta_1 \sin h\{m(\ell - x)\} + \theta_2 \sin h(mx)}{\sin h(m\ell)}$       [Note: All sin h]

(iv)       $\theta = \int_0^\ell h P dx \cdot \theta = \sqrt{hPkA_c} \times (\theta_1 + \theta_2) \frac{[\cosh(m\ell) - 1]}{\sin h(m\ell)}$       [Heat loss by convection]



(v) Maximum temperature occurs at,  $\frac{d\theta}{dx} = 0$

i.e.  $\theta_1 \cosh\{m(\ell - x)\} = \theta_2 \cosh(mx)$

(vi)  $Q_1 = -kA \frac{d\theta}{dx} \Big|_{x=0}$  and  $Q_2 = -kA \frac{d\theta}{dx} \Big|_{x=\ell}$

$\therefore Q = |Q_1 - Q_2|$

## OBJECTIVE QUESTIONS (GATE, IES, IAS)

## Previous 20-Years GATE Questions

**Heat Dissipation from a Fin Insulated at the Tip**

- GATE-1. A fin has 5mm diameter and 100 mm length. The thermal conductivity of fin material is  $400 \text{ Wm}^{-1}\text{K}^{-1}$ . One end of the fin is maintained at  $130^\circ\text{C}$  and its remaining surface is exposed to ambient air at  $30^\circ\text{C}$ . If the convective heat transfer coefficient is  $40 \text{ Wm}^{-2}\text{K}^{-1}$ , the heat loss (in W) from the fin is: [GATE-2010]
- (a) 0.08                      (b) 5.0                      (c) 7.0                      (d) 7.8

**Estimation of Error in Temperature Measurement in a Thermometer Well**

- GATE-2. When the fluid velocity is doubled, the thermal time constant of a thermometer used for measuring the fluid temperature reduces by a factor of 2. [GATE-1994]

## Previous 20-Years IES Questions

- IES-1. From a metallic wall at  $100^\circ\text{C}$ , a metallic rod protrudes to the ambient air. The temperatures at the tip will be minimum when the rod is made of: [IES-1992]
- (a) Aluminium              (b) Steel                      (c) Copper                      (d) Silver
- IES-2. On heat transfer surface, fins are provided [IES-2010]
- (a) To increase temperature gradient so as to enhance heat transfer  
 (b) To increase turbulence in flow for enhancing heat transfer  
 (c) To increase surface area to promote the rate of heat transfer  
 (d) To decrease the pressure drop of the fluid

**Heat Dissipation from an Infinitely Long Fin**

- IES-3. The temperature distribution in a stainless fin (thermal conductivity  $0.17 \text{ W/cm}^\circ\text{C}$ ) of constant cross-sectional area of  $2 \text{ cm}^2$  and length of 1-cm, exposed to ambient of  $40^\circ\text{C}$  (with a surface heat transfer coefficient of  $0.0025 \text{ W/cm}^2\text{C}$ ) is given by  $(T - T_\infty) = 3x^2 - 5x + 6$ , where  $T$  is in  $^\circ\text{C}$  and  $x$  is in cm. If the base temperature is  $100^\circ\text{C}$ , then the heat dissipated by the fin surface will be: [IES-1994]
- (a) 6.8 W                      (b) 3.4 W                      (c) 1.7 W                      (d) 0.17 W

**Heat Dissipation from a Fin Insulated at the Tip**

- IES-4. The insulated tip temperature of a rectangular longitudinal fin having an excess (over ambient) root temperature of  $\theta_o$  is: [IES-2002]  
 (a)  $\theta_o \tan h(ml)$  (b)  $\frac{\theta_o}{\sin h(ml)}$  (c)  $\frac{\theta_o \tan h(ml)}{(ml)}$  (d)  $\frac{\theta_o}{\cosh(ml)}$
- IES-5. The efficiency of a pin fin with insulated tip is: [IES-2001]  
 (a)  $\frac{\tan h mL}{(hA / kP)^{0.5}}$  (b)  $\frac{\tan h mL}{mL}$  (c)  $\frac{mL}{\tan h mL}$  (d)  $\frac{(hA / kP)^{0.5}}{\tan h mL}$
- IES-6. A fin of length 'l' protrudes from a surface held at temperature  $t_o$  greater than the ambient temperature  $t_a$ . The heat dissipation from the free end' of the fin is assumed to be negligible. The temperature gradient at the fin tip  $\left(\frac{dt}{dx}\right)_{x=l}$  is: [IES-1999]  
 (a) Zero (b)  $\frac{t_1 - t_a}{t_o - t_a}$  (c)  $h(t_o - t_l)$  (d)  $\frac{t_o - t_l}{l}$
- IES-7. A fin of length  $l$  protrudes from a surface held at temperature  $T_o$ ; it being higher than the ambient temperature  $T_a$ . The heat dissipation from the free end of the fin is stated to be negligibly small, What is the temperature gradient  $\left(\frac{dT}{dx}\right)_{x=l}$  at the tip of the fin? [IES-2008]  
 (a) Zero (b)  $\frac{T_o - T_l}{l}$  (c)  $h(T_o - T_a)$  (d)  $\frac{T_l - T_a}{T_o - T_a}$

**Efficiency and Effectiveness of Fin**

- IES-8. Which one of the following is correct? [IES-2008]  
 The effectiveness of a fin will be maximum in an environment with  
 (a) Free convection (b) Forced convection  
 (c) Radiation (d) Convection and radiation
- IES-9. Usually fins are provided to increase the rate of heat transfer. But fins also act as insulation. Which one of the following non-dimensional numbers decides this factor? [IES-2007]  
 (a) Eckert number (b) Biot number  
 (c) Fourier number (d) Peclet number
- IES-10. Provision of fins on a given heat transfer surface will be more it there are: [IES-1992]  
 (a) Fewer number of thick fins (b) Fewer number of thin fins  
 (c) Large number of thin fins (d) Large number of thick fins
- IES-11. Which one of the following is correct? [IES-2008]  
 Fins are used to increase the heat transfer from a surface by

- (a) Increasing the temperature difference
- (b) Increasing the effective surface area
- (c) Increasing the convective heat transfer coefficient
- (d) None of the above

**IES-12. Fins are made as thin as possible to:** [IES-2010]

- (a) Reduce the total weight
- (b) Accommodate more number of fins
- (c) Increase the width for the same profile area
- (d) Improve flow of coolant around the fin

**IES-13. In order to achieve maximum heat dissipation, the fin should be designed in such a way that:** [IES-2005]

- (a) It should have maximum lateral surface at the root side of the fin
- (b) It should have maximum lateral surface towards the tip side of the fin
- (c) It should have maximum lateral surface near the centre of the fin
- (d) It should have minimum lateral surface near the centre of the fin

**IES-14. A finned surface consists of root or base area of  $1 \text{ m}^2$  and fin surface area of  $2 \text{ m}^2$ . The average heat transfer coefficient for finned surface is  $20 \text{ W/m}^2\text{K}$ . Effectiveness of fins provided is 0.75. If finned surface with root or base temperature of  $50^\circ\text{C}$  is transferring heat to a fluid at  $30^\circ\text{C}$ , then rate of heat transfer is:** [IES-2003]

- (a) 400 W
- (b) 800 W
- (c) 1000 W
- (d) 1200 W

**IES-15. Consider the following statements pertaining to large heat transfer rate using fins:** [IES-2002]

1. Fins should be used on the side where heat transfer coefficient is small
2. Long and thick fins should be used
3. Short and thin fins should be used
4. Thermal conductivity of fin material should be large

Which of the above statements are correct?

- (a) 1, 2 and 3
- (b) 1, 2 and 4
- (c) 2, 3 and 4
- (d) 1, 3 and 4

**IES-16. Assertion (A): In a liquid-to-gas heat exchanger fins are provided in the gas side.** [IES-2002]

**Reason (R): The gas offers less thermal resistance than liquid**

- (a) Both A and R are individually true and R is the correct explanation of A
- (b) Both A and R are individually true but R is **not** the correct explanation of A
- (c) A is true but R is false
- (d) A is false but R is true

**IES-17. Assertion (A): Nusselt number is always greater than unity.**

**Reason (R): Nusselt number is the ratio of two thermal resistances, one the thermal resistance which would be offered by the fluid, if it was stationary and the other, the thermal resistance associated with convective heat transfer coefficient at the surface.** [IES-2001]

- (a) Both A and R are individually true and R is the correct explanation of A
- (b) Both A and R are individually true but R is **not** the correct explanation of A
- (c) A is true but R is false
- (d) A is false but R is true

- IES-18. Extended surfaces are used to increase the rate of heat transfer. When the convective heat transfer coefficient  $h = mk$ , the addition of extended surface will: [IES-2010]
- Increase the rate of heat transfer
  - Decrease the rate of heat transfer
  - Not increase the rate of heat transfer
  - Increase the rate of heat transfer when the length of the fin is very large
- IES-19. Addition of fin to the surface increases the heat transfer if  $\sqrt{hA/KP}$  is: [IES-1996]
- Equal to one
  - Greater than one
  - Less than one
  - Greater than one but less than two
- IES-20. Consider the following statements pertaining to heat transfer through fins: [IES-1996]
- Fins are equally effective irrespective of whether they are on the hot side or cold side of the fluid.
  - The temperature along the fin is variable and hence the rate of heat transfer varies along the elements of the fin.
  - The fins may be made of materials that have a higher thermal conductivity than the material of the wall.
  - Fins must be arranged at right angles to the direction of flow of the working fluid.
- Of these statements:
- 1 and 2 are correct
  - 2 and 4 are correct
  - 1 and 3 are correct
  - 2 and 3 are correct.

## Previous 20-Years IAS Questions

### Heat Transfer from a Bar Connected to the Two Heat Sources at Different, Temperatures

- IAS-1. A metallic rod of uniform diameter and length  $L$  connects two heat sources each at  $500^\circ\text{C}$ . The atmospheric temperature is  $30^\circ\text{C}$ . The temperature gradient  $\frac{dT}{dL}$  at the centre of the bar will be: [IAS-2001]

- $\frac{500}{L/2}$
- $-\frac{500}{L/2}$
- $-\frac{470}{L/2}$
- Zero

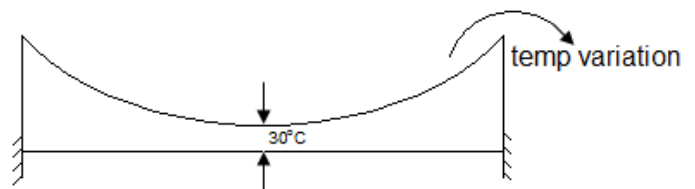

## Answers with Explanation (Objective)

## Previous 20-Years GATE Answers

GATE-1. Ans. (b)  $Q = \sqrt{h p K A} \theta_0 \tanh(ml)$

$$m = \sqrt{\frac{hp}{KA}}; \quad P = 2\pi rl, \quad A = \frac{\pi}{4} d^2$$

Substituting we are getting

$$\therefore Q = 5 \text{ watt}$$

GATE-2. Ans. False

Time constant by,  $\Gamma = \frac{V.P.C}{Ah}$ ,

where  $V = \text{Volume (m}^3\text{)},$   
 $\rho = \text{density (kg/m}^3\text{)},$   
 $C = \text{specific heat kJ/kgK},$   
 $A = \text{Area (m}^2\text{)},$   
 $h = \text{surface film conductance W/M}^2\text{K}.$

When the velocity is doubled,  $h$  increases, thus  $\tau$ , the time constant decreases. But it is not halved as the increase of ' $h$ ' is not two times due to the doubling of velocity.

(Since  $= \frac{k}{\delta}$ ; therefore reduction of boundary layer thickness ' $\delta$ ' is not linearly connected with variation in velocity).

## Previous 20-Years IES Answers

IES-1. Ans. (b)

IES-2. Ans. (c) By the use of a fin, surface area is increased due to which heat flow rate increases. Increase in surface area decreases the surface convection resistance, whereas the conduction resistance increases. The decrease in convection resistance must be greater than the increase in conduction resistance in order to increase the rate of heat transfer from the surface. In practical applications of fins the surface resistance must be the controlling factor (the addition of fins might decrease the heat transfer rate under some situations).

IES-3. Ans. (b) Heat dissipated by fin surface

$$= \sqrt{\frac{hP}{kA}} \frac{t_1 - t_2}{x / kA} = \sqrt{\frac{0.0025 \times 2}{0.17 \times 1}} \times \frac{100 - 40}{1 / 0.17 \times 2} = 3.4 \text{ W}$$

$$\text{or Heat dissipated by fin surface} = h \int_0^l P dx \times (t - t_a)$$

IES-4. Ans. (d)

IES-5. Ans. (b)

IES-6. Ans. (a)

IES-7. Ans. (a)  $hA(T_{at \text{ tip}} - T_a) = -KA \left( \frac{dT}{dx} \right)_{x=l} = \text{Negligibly small.}$

# Heat Transfer from Extended Surfaces (Fins)

## S K Mondal's Chapter 4

Therefore, the temperature gradient  $\left(\frac{dT}{dx}\right)_{x=l}$  at the tip will be negligibly small

i.e. zero.

**IES-8. Ans. (a)** The effectiveness of a fin can also be characterized as

$$\varepsilon_f = \frac{q_f}{q} = \frac{q_f}{hA_C(T_b - T_\infty)} = \frac{(T_b - T_\infty)/R_{t,f}}{(T_b - T_\infty)/R_{t,h}} = \frac{R_{t,h}}{R_{t,f}}$$

It is a ratio of the thermal resistance due to convection to the thermal resistance of a fin. In order to enhance heat transfer, the fin's resistance should be lower than that of the resistance due only to convection.

**IES-9. Ans. (b)**

**IES-10. Ans. (c)**

**IES-11. Ans. (b)**

**IES-12. Ans. (b)** Effectiveness ( $\varepsilon_{fin}$ )

$$\varepsilon_{fin} = \frac{Q_{with\ fin}}{Q_{without\ fin}} = \frac{\sqrt{kP}}{\sqrt{hA_{cs}}} = \frac{\sqrt{hPkA_{cs}}(t_0 - t_a)}{hA_{cs}(t_0 - t_a)}$$

If the ratio  $\frac{P}{A_{cs}}$  is  $\uparrow$   $\varepsilon_{fin}$   $\uparrow$

**IES-13. Ans. (a)**

**IES-14. Ans. (a)**  $\varepsilon = \frac{\sqrt{KP}}{\sqrt{hA_C}} \Rightarrow \sqrt{KP} = 0.75 \times \sqrt{20 \times 1}$

$$\begin{aligned} q_{fin} &= (\sqrt{hPKA_C}) \theta_0 \\ &= \sqrt{20 \times 1} \cdot \sqrt{20 \times 1} \times 0.75 \times 20 \\ &20 \times 0.75 \times 20 = 300\text{ W} \end{aligned}$$

$$\varepsilon = \frac{Q_{fin}}{Q_{without\ fin}} = \frac{300}{75} = 400\text{ W}$$

If  $\varepsilon < 1$ ; fins behave like insulator.

**IES-15. Ans. (d)**

**IES-16. Ans. (c)**

**IES-17. Ans. (a)**

**IES-18. Ans. (c)**

**IES-19. Ans. (c)** Addition of fin to the surface increases the heat transfer if  $\sqrt{hA} / KP \ll 1$ .

**IES-20. Ans. (d)**

## Previous 20-Years IAS Answers

**IAS-1. Ans. (d)**



## 5. One Dimensional Unsteady Conduction

### Theory at a Glance (For IES, GATE, PSU)

#### Heat Conduction in Solids having Infinite Thermal Conductivity (Negligible internal Resistance-Lumped Parameter Analysis)

#### Biot Number ( $B_i$ )

- Defined to describe the relative resistance in a thermal circuit of the convection compared

$$B_i = \frac{hL_c}{k} = \frac{L_c / kA}{1/hA} = \frac{\text{Internal conduction resistance within solid}}{\text{External convection resistance at body surface}}$$

$L_c$  Is a characteristic length of the body.

$B_i \rightarrow 0$ : No conduction resistance at all. The body is isothermal.

**Small  $B_i$ :** Conduction resistance is less important. The body may still be approximated as isothermal (purple temperature plot in figure) *Lumped capacitance analysis* can be performed.

**Large  $B_i$ :** Conduction resistance is significant. The body cannot be treated as isothermal (blue temperature plot in figure).

Many heat transfer problems require the understanding of the complete time history of the temperature variation. For example, in metallurgy, the heat treating process can be controlled to directly affect the characteristics of the processed materials. Annealing (slow cool) can soften metals and improve ductility. On the other hand, quenching (rapid cool) can harden the strain boundary and increase strength. In order to characterize this transient behavior, the full unsteady equation is needed:

$$\rho c \frac{\partial T}{\partial t} = k \nabla^2 T, \text{ or } \frac{1}{\alpha} \frac{\partial T}{\partial t} = \nabla^2 T$$

Where  $\alpha = \frac{k}{\rho c}$  is the thermal diffusivity.



# One Dimensional Unsteady Conduction

## S K Mondal's

## Chapter 5

“A heated/cooled body at  $T_i$  is suddenly exposed to fluid at  $T_\infty$  with a known heat transfer coefficient. Either evaluate the temperature at a given time, or find time for a given temperature.”

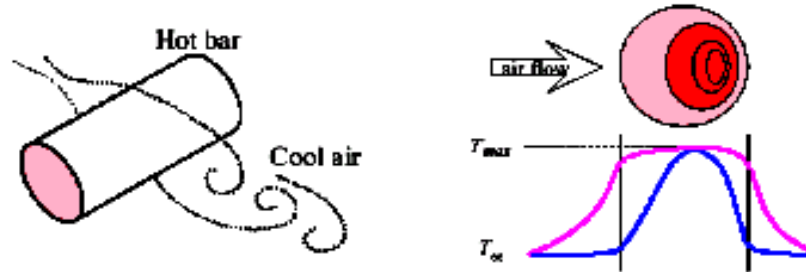

**Question:** “How good an approximation would it be to say the bar is more or less *isothermal*?”

**Answer:** “Depends on the relative importance of the thermal conductivity in the thermal circuit compared to the convective heat transfer coefficient”.

The process in which the *internal resistance is assumed negligible in comparison with its surface resistance* is called the **Newtonian heating or cooling process**. The temperature, in this process, is considered to be uniform at a given time. Such an analysis is called *Lumped parameter analysis* because the whole solid, whose energy at any time is a *function of its temperature* and total heat capacity is treated as *one lump*.

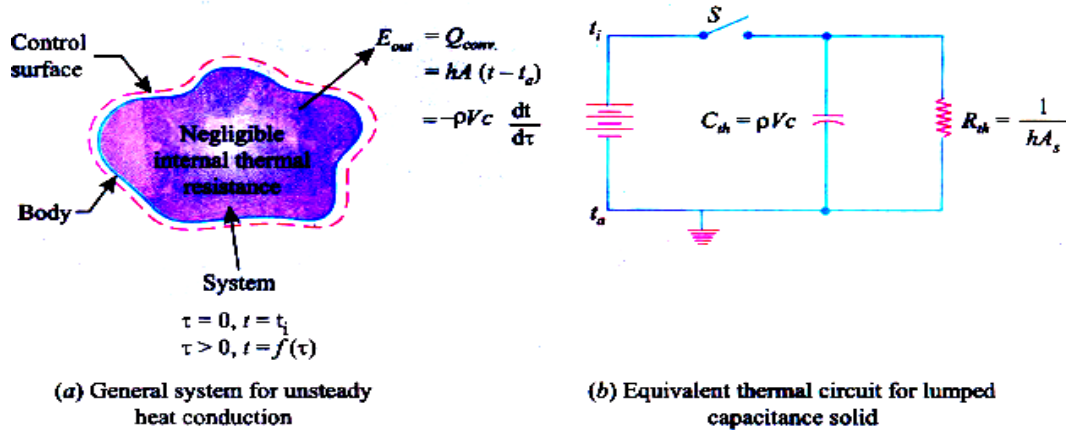

$\frac{L}{kA}$  = internal resistance of body.

Now,  $\frac{L}{kA} \ll \frac{1}{hA}$

If **k** is very high the process in which the internal resistance or is assumed negligible in comparison with its surface resistance is called the Newtonian heating or cooling process.

$$Q = -\rho Vc \frac{dt}{d\tau} = h A_s (t - t_a)$$

$$\frac{dt}{t - t_a} = -\frac{hA_s}{\rho Vc} \tau + c_1$$

At  $\tau = 0$ ,  $t = t_i$

$$c_1 = \ln(t_i - t_a)$$

$$\therefore \frac{\theta}{\theta_i} = e^{-\frac{hA_s \tau}{\rho Vc}}$$

$$\frac{hA_s}{\rho Vc} \tau = \frac{hV}{kA_s} \cdot \frac{A_s^2 k}{\rho V^2 c} \tau = \left(\frac{hL_c}{k}\right) \cdot \left(\frac{\alpha \tau}{L_c^2}\right) = B_i \times F_0$$

where,  $B_i$  = Biot number &  $F_0$  = Fourier number

Where,

- $\rho$  = Density of solid, kg/m<sup>3</sup>,
- $V$  = Volume of the body, m<sup>3</sup>,
- $c$  = Specific heat of body, J/kg°C,
- $h$  = Unit surface conductance, W/m<sup>2</sup>°C,
- $t$  = Temperature of the body at any time, °C,
- $A_s$  = Surface area of the body, m<sup>2</sup>,
- $t_a$  = Ambient temperature, °C, and
- $\tau$  = Time, s.

Now,

$$\frac{\theta}{\theta_i} = e^{-B_i \times F_0}$$

$$Q_i = \rho Vc \frac{dt}{d\tau} = \rho Vc [(t_i - t_a)] \left\{ \frac{-hA_s}{\rho Vc} \right\} e^{-B_i \times F_0} = -hA_s (t_i - t_a) e^{-B_i \times F_0}$$

$$Q_{total} = \int_0^{\tau} Q_i d\tau = \rho Vc (t_i - t_a) [e^{-B_i \times F_0} - 1]$$

## Algorithm

**Step-I: Characteristic Length,  $L_c = \frac{V}{A_s}$**

**Step-II: Biot Number =  $\frac{hL_c}{k}$**

Check  $Bi \leq 0.1$  or not if yes then

**Step-III: Thermal Diffusivity**

$$\alpha = \frac{k}{\rho C_p}$$

**Step-IV: Four numbers ( $F_0$ ) =  $\frac{\alpha \tau}{L_c^2}$**

**Step-V:**  $\frac{t - t_a}{t_i - t_a} = e^{-Bi \times F_0}$

**Step-VI:**  $Q_{total} = \rho V c (t_i - t_a) [e^{-Bi \times F_0} - 1]$

## Spatial Effects and the Role of Analytical Solutions

If the lumped capacitance approximation can not be made, consideration must be given to spatial, as well as temporal, variations in temperature during the transient process.

**The Plane Wall:** Solution to the Heat Equation for a Plane Wall with Symmetrical Convection Conditions.

- For a plane wall with symmetrical convection conditions and constant properties, the heat equation and initial boundary conditions are:

$$\frac{1}{a} \cdot \frac{\partial T}{\partial \tau} = \frac{\partial^2 T}{\partial x^2}$$

$$T(x, 0) = T_i$$

$$\left. \frac{\partial T}{\partial x} \right|_{x=0} = 0$$

$$-k \left. \frac{\partial T}{\partial x} \right|_{x=L} = h [T(L, t) - T_\infty]$$

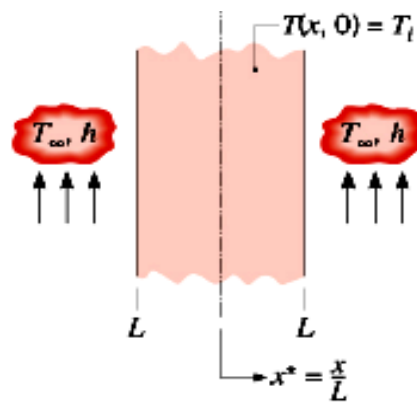

**Note:** Once spatial variability of temperature is included, there is existence of seven different independent variables.

$$T = T(x, t, T_i, T_\infty, h, k, \alpha)$$

How may the functional dependence be simplified?

- The answer is **Non-dimensionalisation**. We first need to understand the physics behind the phenomenon, identify parameters governing the process, and group them into meaningful non-dimensional numbers.

### Non-dimensionalisation of Heat Equation and Initial/Boundary Conditions:

The following dimensionless quantities are defined.

Dimensionless temperature difference:  $\theta^* = \frac{\theta}{\theta_i} = \frac{T - T_\infty}{T_i - T_\infty}$

Dimensionless coordinate:  $x^* = \frac{x}{L}$

Dimensionless time:  $t^* = \frac{\alpha t}{L^2} F_0$

The Biot Number:  $Bi = \frac{hL}{k_{solid}}$

The solution for temperature will now be a function of the other non-dimensional quantities

$$\theta^* = f(x^*, Fo, Bi)$$

Exact Solution:

$$\theta^* = \sum_{n=1}^{\infty} C_n \exp(-\zeta_n^2 Fo) \cos(\zeta_n x^*)$$

$$C_n = \frac{4 \sin \zeta_n}{2 \zeta_n + \sin(2 \zeta_n)} \qquad \zeta_n \tan \zeta_n = Bi$$

The roots (eigen values) of the equation can be obtained.

The One-Term Approximation  $Fo > 0.2$

Variation of mid-plane ( $x^* = 0$ ) temperature with time ( $Fo$ )

$$\theta_0^* = \frac{T - T_{\infty}}{T_i - T_{\infty}} \approx C_1 \exp(-\zeta_1^2 Fo)$$

One can obtain  $C_1$  and  $\zeta_1$  as a function of  $Bi$ .

Variation of temperature with location ( $x^* = 0$ ) and time ( $Fo$ ):

$$\theta^* = \theta_0^* = \cos(\zeta_1 x^*)$$

Change in thermal energy storage with time:

$$\Delta E_{st} = -Q$$

$$Q = Q_0 \left( 1 - \frac{\sin \zeta_1}{\zeta_1} \right) \theta_0^*$$

$$Q_0 = \rho c V (T_i - T_{\infty})$$

Can the foregoing results be used for a plane wall that is well insulated on one side and convectively heated or cooled on the other? Can the foregoing results be used if an isothermal condition ( $T_s \neq T_i$ ) is instantaneously imposed on both surfaces of a plane wall or on one surface of a wall whose other surface is well insulated?

## **Graphical Representation of the One-Term Approximation:**

### **The Heisler Charts**

#### **Midplane Temperature:**

# One Dimensional Unsteady Conduction

**S K Mondal's****Chapter 5**

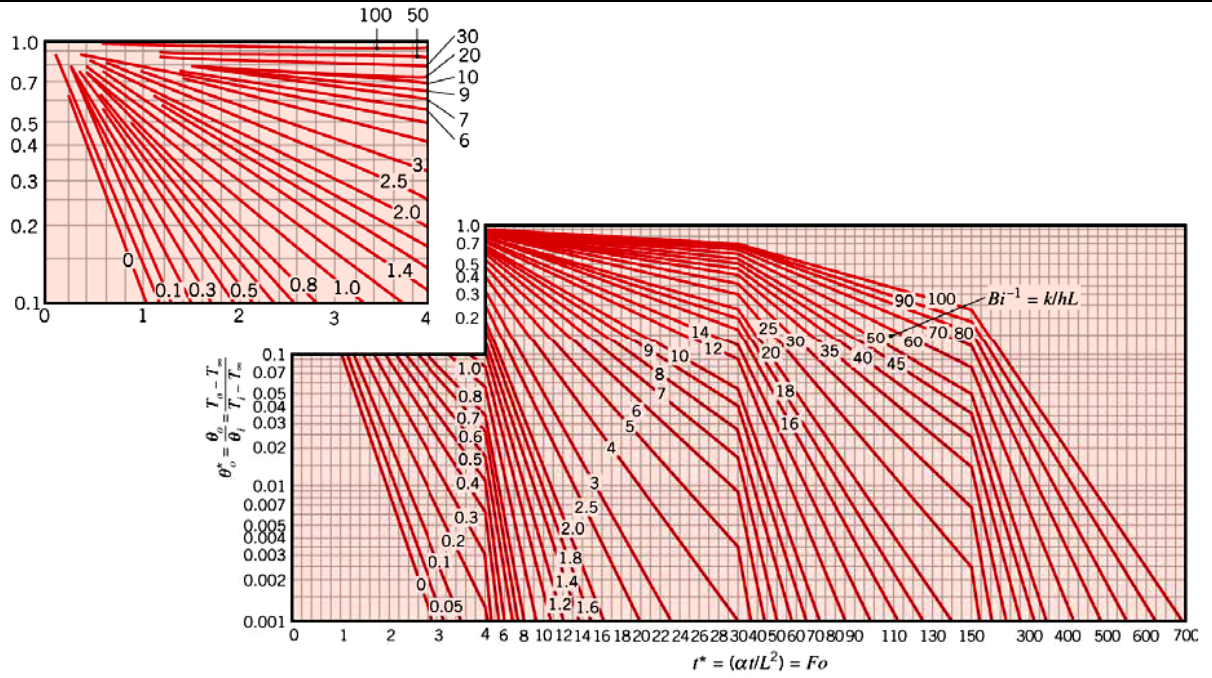

## Temperature Distribution

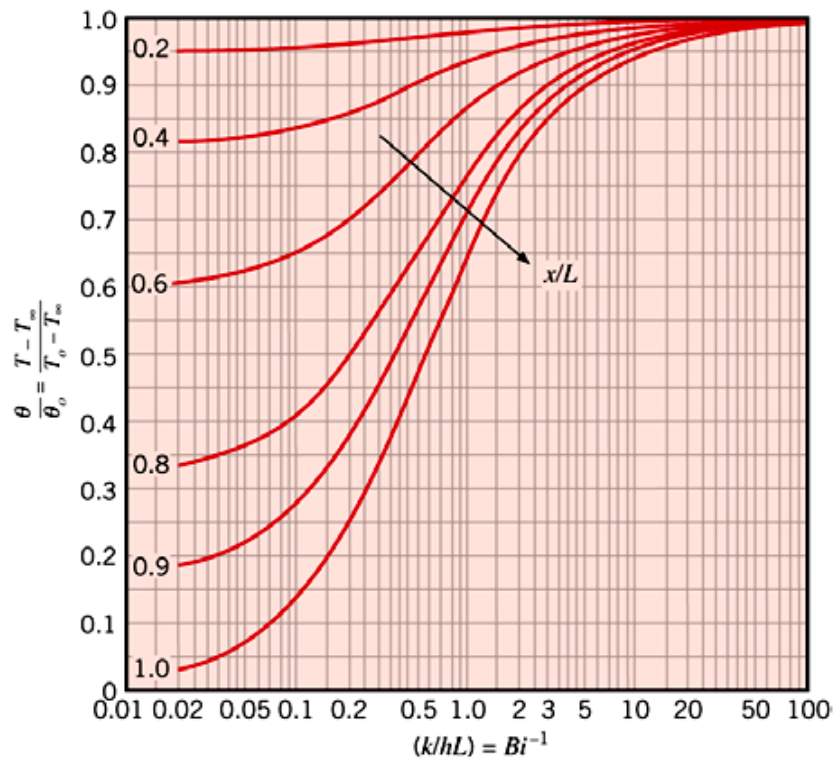

Change in Thermal Energy Storage

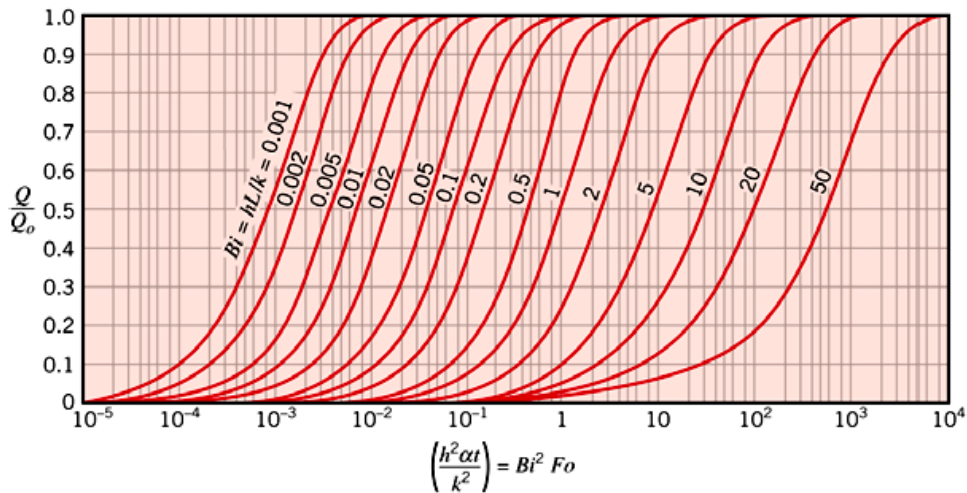

- **Assumptions in using Heisler charts:**
  1. Constant  $T_i$  and thermal properties over the body
  2. Constant boundary fluid  $T_\infty$  by step change
  3. Simple geometry: slab, cylinder or sphere
  
- **Limitations:**
  1. Far from edges
  2. No heat generation ( $Q = 0$ )
  3. Relatively long after initial times ( $Fo > 0.2$ )

Radial Systems

Long Rods or Spheres Heated or Cooled by Convection

$$B_i = hr_0 / k$$

$$F_0 = \alpha t / r_0^2$$

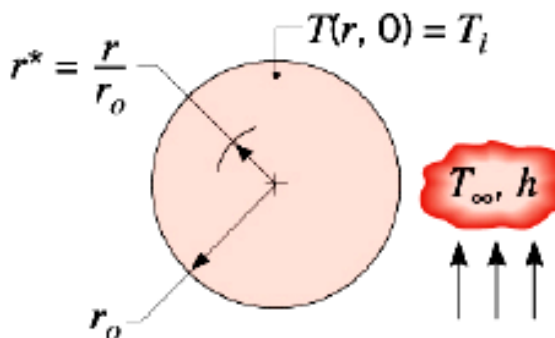

**Important tips:** Pay attention to the length scale used in those charts, and calculate your Biot number accordingly.

**OBJECTIVE QUESTIONS (GATE, IES, IAS)**

**Previous 20-Years GATE Questions**

**Heat Conduction in Solids having Infinite Thermal Conductivity (Negligible internal Resistance-Lumped Parameter Analysis)**

- GATE-1.** The value of Biot number is very small (less than 0.01) when  
(a) The convective resistance of the fluid is negligible [GATE-2002]  
(b) The conductive resistance of the fluid is negligible  
(c) The conductive resistance of the solid is negligible  
(d) None of these
- GATE-2.** A small copper ball of 5 mm diameter at 500 K is dropped into an oil bath whose temperature is 300 K. The thermal conductivity of copper is 400 W/mK, its density 9000 kg/m<sup>3</sup> and its specific heat 385 J/kg.K. If the heat transfer coefficient is 250 W/m<sup>2</sup>K and lumped analysis is assumed to be valid, the rate of fall of the temperature of the ball at the beginning of cooling will be, in K/s. [GATE-2005]  
(a) 8.7 (b) 13.9 (c) 17.3 (d) 27.7
- GATE-3.** A spherical thermocouple junction of diameter 0.706 mm is to be used for the measurement of temperature of a gas stream. The convective heat transfer co-efficient on the bead surface is 400 W/m<sup>2</sup>K. Thermophysical properties of thermocouple material are  $k = 20$  W/mK,  $C = 400$  J/kg,  $K$  and  $\rho = 8500$  kg/m<sup>3</sup>. If the thermocouple initially at 30°C is placed in a hot stream of 300°C, then time taken by the bead to reach 298°C, is: [GATE-2004]  
(a) 2.35 s (b) 4.9 s (c) 14.7 s (d) 29.4 s

**Previous 20-Years IES Questions**

**Heat Conduction in Solids having Infinite Thermal Conductivity (Negligible internal Resistance-Lumped Parameter Analysis)**

- IES-1.** Assertion (A): Lumped capacity analysis of unsteady heat conduction assumes a constant uniform temperature throughout a solid body.  
Reason (R): The surface convection resistance is very large compared with the internal conduction resistance. [IES-2010]
- IES-2.** The ratio  $\frac{\text{Internal conduction resistance}}{\text{Surface convection resistance}}$  is known as [IES-1992]  
(a) Grashoff number (b) Biot number

(c) Stanton number

(b) Prandtl number

**IES-3. Which one of the following statements is correct? [IES-2004]**

**The curve for unsteady state cooling or heating of bodies**

- (a) Parabolic curve asymptotic to time axis
- (b) Exponential curve asymptotic to time axis
- (c) Exponential curve asymptotic both to time and temperature axis
- (d) Hyperbolic curve asymptotic both to time and temperature axis

**IES-4. Assertion (A): In lumped heat capacity systems the temperature gradient within the system is negligible [IES-2004]**

**Reason (R): In analysis of lumped capacity systems the thermal conductivity of the system material is considered very high irrespective of the size of the system**

- (a) Both A and R are individually true and R is the correct explanation of A
- (b) Both A and R are individually true but R is **not** the correct explanation of A
- (c) A is true but R is false
- (d) A is false but R is true

**IES-5. A solid copper ball of mass 500 grams, when quenched in a water bath at 30°C, cools from 530°C to 430°C in 10 seconds. What will be the temperature of the ball after the next 10 seconds? [IES-1997]**

- (a) 300°C
- (b) 320°C
- (c) 350°C
- (d) Not determinable for want of sufficient data

## **Time Constant and Response of — Temperature Measuring Instruments**

**IES-6. A thermocouple in a thermo-well measures the temperature of hot gas flowing through the pipe. For the most accurate measurement of temperature, the thermo-well should be made of: [IES-1997]**

- (a) Steel
- (b) Brass
- (c) Copper
- (d) Aluminium

## **Transient Heat Conduction in Semi-infinite Solids (*h* or *Hj* 4.5. 30~5 00)**

**IES-7. Heisler charts are used to determine transient heat flow rate and temperature distribution when: [IES-2005]**

- (a) Solids possess infinitely large thermal conductivity
- (b) Internal conduction resistance is small and convective resistance is large
- (c) Internal conduction resistance is large and the convective resistance is small
- (d) Both conduction and convection resistance are almost of equal significance



## Time Constant and Response of — Temperature Measuring Instruments

IAS-1. Assertion (A): During the temperature measurement of hot gas in a duct that has relatively cool walls, the temperature indicated by the thermometer will be lower than the true hot gas temperature.

Reason(R): The sensing tip of thermometer receives energy from the hot gas and loses heat to the duct walls. [IAS-2000]

- (a) Both A and R are individually true and R is the correct explanation of A
- (b) Both A and R are individually true but R is **not** the correct explanation of A
- (c) A is true but R is false
- (d) A is false but R is true

**Answers with Explanation (Objective)**

**Previous 20-Years GATE Answers**

**GATE-1. Ans. (c)**

**GATE-2. Ans. (c)**

$$\text{Characteristic length } (L_c) = \frac{V}{A_s} = \frac{\frac{4}{3}\pi r^3}{4\pi r^2} = \frac{r}{3} = \frac{0.005/2}{3} = 8.3333 \times 10^{-4} \text{ m}$$

$$\text{Thermal diffusivity, } \alpha = \frac{k}{\rho c_p} = \frac{400}{9000 \times 385} = 1.1544 \times 10^{-4}$$

$$\text{Fourier number } (F_o) = \frac{\alpha \tau}{L_c^2} = 166\tau$$

$$\text{Biot number } (B_i) = \frac{hL_c}{k} = \frac{250 \times 8.3333 \times 10^{-4}}{400} = 5.208 \times 10^{-4}$$

Then,

$$\frac{\theta}{\theta_i} = \frac{T - T_a}{T_i - T_a} = e^{-B_i \times F_o} \quad \text{or} \quad \frac{T - 300}{500 - 300} = e^{-166\tau \times 5.208 \times 10^{-4}}$$

$$\text{or } \ln(T - 300) - \ln 200 = -0.08646 \tau$$

$$\text{or } \frac{1}{(T - 300)} \frac{dT}{d\tau} = -0.08646 \quad \text{or} \quad \left( \frac{dT}{d\tau} \right)_{T \approx 500K} = -0.08646 \times (500 - 300) = -17.3 \text{ K/s}$$

**GATE-3. Ans. (b)** Characteristic length  $(L_c) = \frac{V}{A} = \frac{\frac{4}{3}\pi r^3}{4\pi r^2} = \frac{r}{3} = 0.11767 \times 10^{-3} \text{ m}$

$$\text{Biot number } (B_i) = \frac{hL_c}{k} = \frac{400 \times (0.11767 \times 10^{-3})}{20} = 2.3533 \times 10^{-3}$$

As  $B_i < 0.1$  the lumped heat capacity approach can be used

$$\alpha = \frac{k}{\rho c_p} = \frac{20}{8500 \times 400} = 5.882 \times 10^{-6} \text{ m}^2/\text{s}$$

$$\text{Fourier number } (F_o) = \frac{\alpha \tau}{L_c^2} = 425\tau$$

$$\frac{\theta}{\theta_i} = e^{-F_o \cdot B_i} \quad \text{or} \quad F_o \cdot B_i = \ln \left( \frac{\theta}{\theta_i} \right)$$

$$\text{or } 425\tau \times 2.3533 \times 10^{-3} = \ln \left( \frac{300 - 30}{300 - 298} \right) \quad \text{or } \tau = 4.9 \text{ s}$$

Previous 20-Years IES Answers

**IES-1. Ans. (a)**

**IES-2. Ans. (b)**

**IES-3. Ans. (b)**  $\frac{Q}{Q_o} = e^{-B_i \times F_o}$

**IES-4. Ans. (a)** If Biot number ( $B_i$ ) =  $\frac{hL_c}{k} = \frac{h}{k} \left( \frac{V}{A_s} \right) < 0.1$  then use lumped heat capacity

approach. It depends on size.

**IES-5. Ans. (c)** In first 10 seconds, temperature is fallen by 100°C. In next 10 seconds fall will be less than 100°C.

∴ 350°C appears correct solution.

You don't need following lengthy calculations (remember calculators are not allowed in IES objective tests).

This is the case of unsteady state heat conduction.

$T_t$  = Fluid temperature

$T_o$  = Initial temperature

$T$  = Temperature after elapsing time 't'

Heat transferred = Change in internal energy

$$hA(T - T_t) = -mC_p \left( \frac{dT}{dt} \right)$$

This is derived to

$$\frac{\theta}{\theta_o} = e^{-\frac{hAt}{\rho C_p V}} \quad \text{or} \quad \frac{T - T_\infty}{T_o - T_\infty} = e^{-\frac{hAt}{\rho C_p V}}$$

$$\text{or} \quad \frac{430 - 30}{530 - 30} = 0.8 = e^{-\frac{hA}{\rho C_p V} t} \quad (t = 10 \text{ sec})$$

After 20 sec (2t):

$$\frac{T - 30}{530 - 30} = e^{-\frac{hA}{\rho C_p V} (2t)} = \left[ e^{-\frac{hA}{\rho C_p V} t} \right]^2 \quad \text{or} \quad \frac{T - 30}{500} = (0.8)^2 = 0.64$$

∴  $T = 350^\circ\text{C}$

**IES-6. Ans. (a)**

**IES-7. Ans. (d)**

Previous 20-Years IAS Answers

**IAS-1. Ans. (a)**

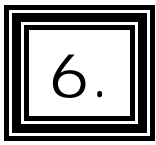

## 6. Free & Forced Convection

### Theory at a Glance (For IES, GATE, PSU)

#### Objectives of Convection Analysis

Main purpose of convective heat transfer analysis is to determine:

- Flow field
- Temperature field in fluid
- Heat transfer coefficient, ( $h$ )

#### How do we determine $h$ ?

Consider the process of convective cooling, as we pass a cool fluid past a heated wall. This process is described by Newton's law of Cooling;

$$q = h \cdot A \cdot (T_s - T_\infty)$$

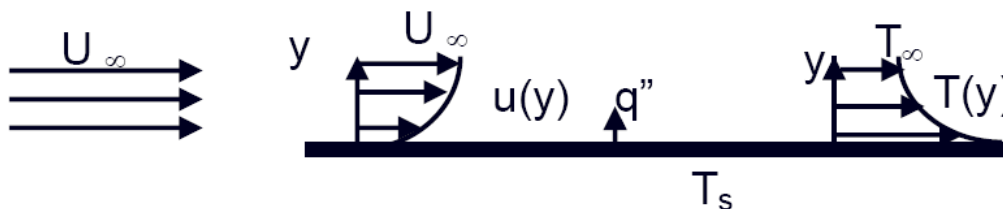

Near any wall a fluid is subject to the no slip condition; that is, there is a stagnant sub layer. Since there is no fluid motion in this layer, heat transfer is by conduction in this region. Above the sub layer is a region where viscous forces retard fluid motion; in this region some convection may occur, but conduction may well predominate. A careful analysis of this region allows us to use our conductive analysis in analyzing heat transfer. This is the basis of our convective theory.

At the wall, the convective heat transfer rate can be expressed as the heat flux.

$$q_{conv} = -k_f \left( \frac{\partial T}{\partial y} \right)_{y=0} = h(T_s - T_\infty)$$

$$\text{Hence, } h = \frac{-k_f \left( \frac{\partial T}{\partial y} \right)_{y=0}}{(T_s - T_\infty)}$$

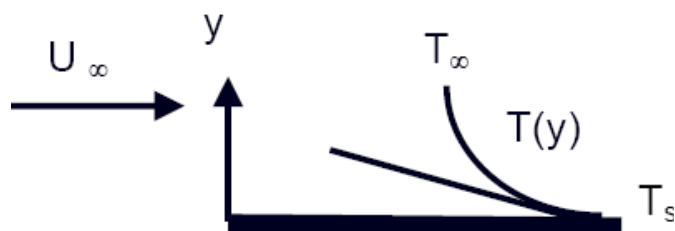

But  $\left(\frac{\partial T}{\partial y}\right)_{y=0}$  depends on the whole fluid motion, and both fluid flow and heat transfer equations are needed.

The expression shows that in order to determine  $h$ , we must first determine the temperature distribution in the thin fluid layer that coats the wall.

**Classes of Convective Flows:**

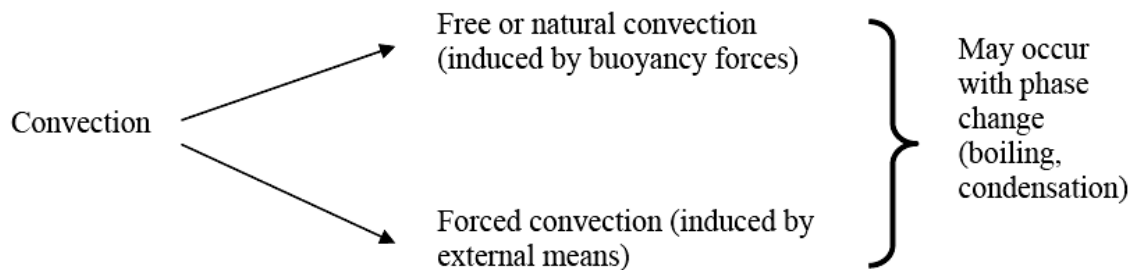

- Extremely diverse.
- Several parameters involved (fluid properties, geometry, nature of flow, phases etc).
- Systematic approach required.
- Classify flows into certain types, based on certain parameters.
- Identify parameters governing the flow, and group them into **meaningful non-dimensional numbers**.
- Need to understand the physics behind each phenomenon.

**Common Classifications**

- A. Based on geometry:  
External flow / Internal flow
- B. Based on driving mechanism:-  
Natural convection / forced convection / mixed convection
- C. Based on nature of flow:  
Laminar / turbulent.

**Typical values of  $h$  (W/m<sup>2</sup>k)**

Free convection	Gases : 2 – 25
	Liquid : 50 – 100
Forced convection	Gases : 25 – 250
	Liquid : 50 – 20,000
Boiling/ Condensation	2500 – 100,000

## How to Solve a Convection Problem?

- Solve governing equations along with boundary conditions
- Governing equations include

1. **Conservation of mass:**  $\frac{\partial u}{\partial x} + \frac{\partial v}{\partial y} = 0$

2. **Conservation of momentum:**  $u \frac{\partial u}{\partial x} + v \frac{\partial u}{\partial y} = U \frac{dU}{dx} + \frac{\partial}{\partial y} \left( \nu \frac{\partial u}{\partial y} \right)$

3. **Conservation of energy:**  $u \frac{\partial T}{\partial x} + v \frac{\partial T}{\partial y} = \frac{\partial}{\partial y} \left( \alpha \frac{\partial T}{\partial y} \right)$

For flat plate  $U = \text{constant}$ ;  $\therefore \frac{dU}{dx} = 0$

Exact solution: Blasius

$$\frac{\delta}{x} = \frac{4.99}{\sqrt{\text{Re}_x}}$$

$$\text{Local friction co-efficient, } (C_x) = \frac{\tau_0}{\frac{1}{2} \rho U^2} = \frac{0.664}{\sqrt{\text{Re}_x}}$$

$$\text{Re}_x = \frac{U_x}{\nu}, \tau_0 = \mu \left. \frac{\partial u}{\partial y} \right|_{y=0}$$

$$\text{Average drag co-efficient, } (C_D) = \frac{1}{L} \int_0^L C_x dx = \frac{1.328}{\sqrt{\text{Re}_L}}$$

$$\text{Local Nusselt number, } (Nu_x) = 0.339 \text{Re}_x^{1/2} \text{Pr}^{1/3}$$

$$\text{Average Nusselt number, } (\overline{Nu_x}) = 0.678 \text{Re}_L^{1/2} \text{Pr}^{1/3}$$

$$\therefore \text{Local heat transfer co-efficient, } (h_x) = \frac{Nu_x \cdot k}{x} = 0.339 \frac{k}{x} \text{Re}_x^{1/2} \text{Pr}^{1/3}$$

$$\text{Average heat transfer co-efficient, } (\overline{h}) = \frac{\overline{Nu_x} \cdot k}{L} = 0.678 \frac{k}{L} \cdot \text{Re}_L^{1/2} \text{Pr}^{1/3}$$

Recall  $q = \overline{h} A (T_w - T_\alpha)$  heat flow rate from wall.

- In Conduction problems, only some equation is needed to be solved. Hence, only *few parameters* are involved.
  - In Convection, all the governing equations need to be solved.
- $\Rightarrow$  Large number of parameters can be involved.

### Forced Convection: External Flow (over flat plate)

An internal flow is surrounded by solid boundaries that can restrict the development of its boundary layer, for example, a pipe flow. External flows, on the other hand, are flows over bodies immersed in an unbounded fluid so that the flow boundary layer can grow freely in one direction. Examples include the flows over airfoils, ship hulls, turbine blades, etc.

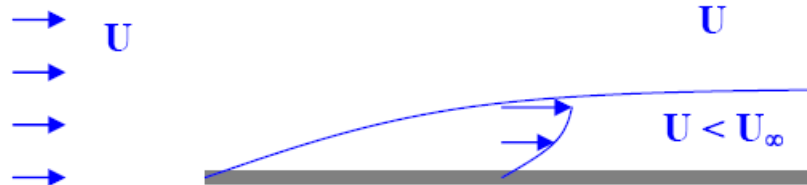

- Fluid particle adjacent to the solid surface is at rest.
- These particles act to retard the motion of adjoining layers.
- Boundary layer effect.

Inside the boundary layer, we can apply the following conservation principles:

**Momentum balance:** inertia forces, pressure gradient, viscous forces, body forces.

**Energy balance:** convective flux, diffusive flux, heat generation, energy storage.

### Forced Convection Correlations

Since the heat transfer coefficient is a direct function of the temperature gradient next to the wall, the physical variables on which it depends can be expressed as follows:  $h = f$  (fluid properties, velocity field, geometry, temperature etc.).

As the function is dependent on several parameters, the heat transfer coefficient is usually expressed in terms of **correlations involving pertinent non-dimensional numbers**.

Forced convection: **Non-dimensional groupings:** —

• <b>Nusselt Number (Nu)</b>	$hx / k$	(Convection heat transfer strength) / (conduction heat transfer strength)
• <b>Prandtl Number (Pr)</b>	$\nu / \alpha$	(Momentum diffusivity) / (thermal diffusivity)
• <b>Reynolds Number (Re)</b>	$Ux / \nu$	(Inertia force) / (viscous force)

Viscous force provides the dampening effect for disturbances in the fluid. If dampening is strong enough  $\Rightarrow$  **laminar flow**.

Otherwise, instability  $\Rightarrow$  **turbulent flow**  $\Rightarrow$  **critical Reynolds number**.

For forced convection, the heat transfer correlation can be expressed as

$$Nu = f(Re, Pr)$$

The convective correlation for laminar flow across a flat plate heated to a constant wall Temperature is:

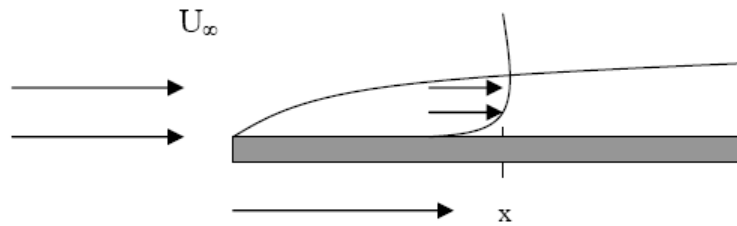

$$\text{Nu}_x = 0.323 \cdot \text{Re}_x^{1/2} \cdot \text{Pr}^{1/3}$$

Where

$$\text{Nu}_x \equiv \text{h} \cdot \text{x} / \text{k}$$

$$\text{Re}_x \equiv (\text{U}_\infty \cdot \text{x} \cdot \rho) / \mu$$

$$\text{Pr} \equiv \text{c}_p \cdot \mu / \text{k}$$

## Physical Interpretation of Convective Correlation

The Reynolds number is a familiar term to all of us, but we may benefit by considering what the ratio tells us. Recall that the thickness of the dynamic boundary layer,  $\delta$ , is proportional to the distance along the plate,  $x$ .

$$\text{Re}_x \equiv (\text{U}_\infty \cdot \text{x} \cdot \rho) / \mu \propto (\text{U}_\infty \cdot \delta \cdot \rho) / \mu = (\rho \cdot \text{U}_\infty^2) / (\mu \cdot \text{U}_\infty / \delta)$$

The numerator is a mass flow per unit area times a velocity; i.e. a momentum flow per unit area. The denominator is a viscous stress, i.e. a viscous force per unit area. The ratio represents the ratio of momentum to viscous forces. If viscous forces dominate, the flow will be laminar; if momentum dominates, the flow will be turbulent.

## Physical Meaning of Prandtl Number

The Prandtl number was introduced earlier.

If we multiply and divide the equation by the fluid density,  $\rho$ , we obtain:

$$\text{Pr} \equiv (\mu / \rho) (\text{k} / \rho \cdot \text{c}_p) = \nu / \alpha$$

The Prandtl number may be seen to be a ratio reflecting the ratio of the rate that viscous forces penetrate the material to the rate that thermal energy penetrates the material. As a consequence the Prandtl number is proportional to the rate of growth of the two boundary layers:

$$\delta / \delta_t = \text{Pr}^{1/3}$$

## Physical Meaning of Nusselt Number

The Nusselt number may be physically described as well.

$$\text{Nu}_x \equiv \text{h} \cdot \text{x} / \text{k}$$

If we recall that the thickness of the boundary layer at any point along the surface,  $\delta$ , is also a function of  $x$  then

$$\text{Nu}_x \propto \text{h} \cdot \delta / \text{k} \propto (\delta / \text{k} \cdot \text{A}) / (1 / \text{h} \cdot \text{A})$$

We see that the Nusselt may be viewed as the ratio of the conduction resistance of a material to the convection resistance of the same material.



Students, recalling the Biot number, may wish to compare the two so that they may distinguish the two.

$$\text{Nu}_x \equiv \mathbf{h.x/k}_{\text{fluid}}$$

$$\text{Bi}_x \equiv \mathbf{h.x/k}_{\text{solid}}$$

The denominator of the Nusselt number involves the thermal conductivity of the **fluid** at the solid-fluid convective interface; the denominator of the Biot number involves the thermal conductivity of the **solid** at the solid-fluid convective interface.

## Local Nature of Convective Correlation

Consider again the correlation that we have developed for laminar flow over a flat plate at constant wall temperature

$$\text{Nu}_x = 0.323.\text{Re}_x^{1/2}.\text{Pr}^{1/3}$$

To put this back into dimensional form, we replace the Nusselt number by its equivalent,  $hx/k$  and take the  $x/k$  to the other side:

$$\mathbf{h} = 0.323.(k/x).\text{Re}_x^{1/2}.\text{Pr}^{1/3}$$

Now expand the Reynolds number

$$\mathbf{h} = 0.323.(k/x).\left[(U_\infty.x.\rho) / \mu\right]^{1/2}.\text{Pr}^{1/3}$$

We proceed to combine the  $x$  terms:

$$\mathbf{h} = 0.323.k.\left[(U_\infty.\rho) / x\mu\right]^{1/2}.\text{Pr}^{1/3}$$

And see that the convective coefficient decreases with  $x^{1/2}$

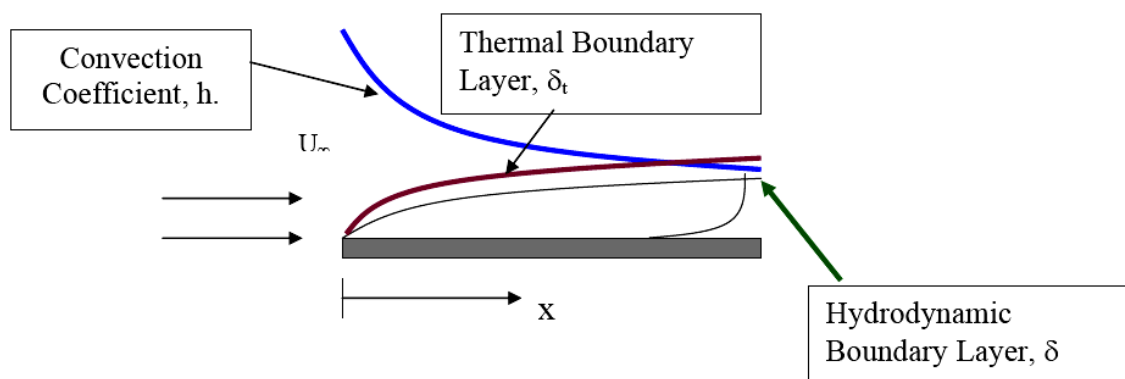

We see that as the boundary layer thickness, the convection coefficient decreases. Some designers will introduce a series of “**trip wires**”, i.e. devices to disrupt the boundary layer, so that the build up of the insulating layer must begin a new. This will result in regular “**thinning**” of the boundary layer so that the convection coefficient will remain high.

## Use of the “Local Correlation”

A local correlation may be used whenever it is necessary to find the convection coefficient at a particular location along a surface. For example, consider the effect of chip placement upon a printed circuit board:

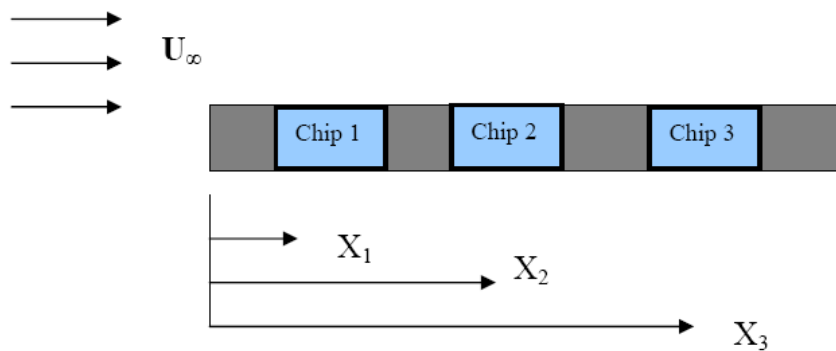

Here are the design conditions. We know that as the higher the operating temperature of a chip, the lower the life expectancy.

With this in mind, we might choose to operate all chips at the same design temperature.

Where the chip generating the largest power per unit surface area should be placed? The lowest power?

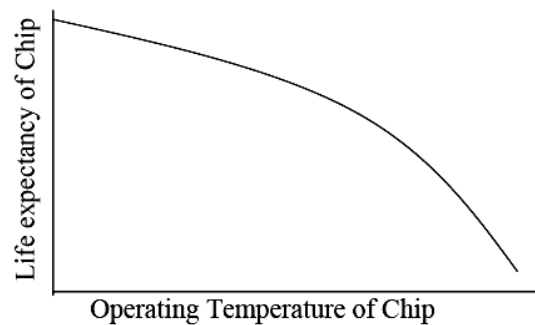

### Averaged Correlations

If one were interested in the total heat loss from a surface, rather than the temperature at a point, then they may well want to know something about average convective coefficients. For example, if we were trying to select a heater to go inside an aquarium, we would not be interested in the heat loss at 5 cm, 7 cm and 10 cm from the edge of the aquarium; instead we want some sort of an average heat loss.

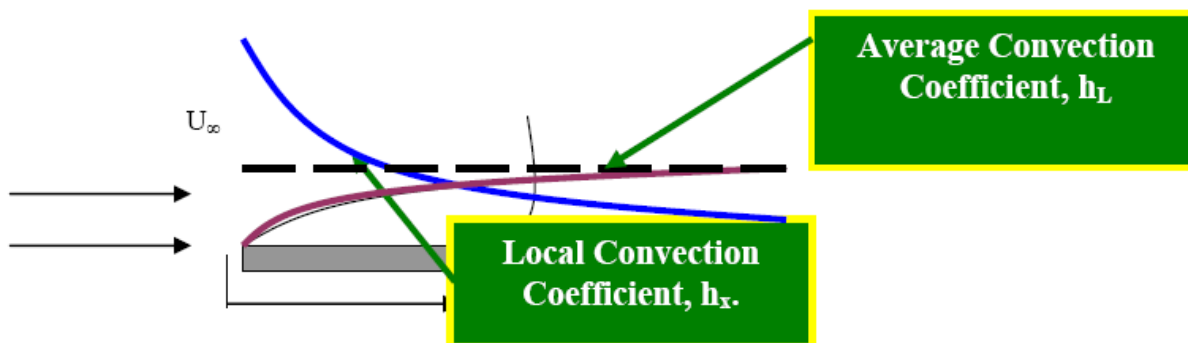

The desire is to find a correlation that provides an overall heat transfer rate:

$$Q = h_L \cdot A \cdot [T_{\text{wall}} - T_\infty] = \int h_x \cdot [T_{\text{wall}} - T_\infty] \cdot dA = \int_0^L h_x \cdot [T_{\text{wall}} - T_\infty] \cdot dx$$

Where  $h_x$  and  $h_L$ , refer to local and average convective coefficients, respectively.

Compare the equations where the area is assumed to be equal to  $A = (1 \cdot L)$ :

$$h_L \cdot L \cdot [T_{\text{wall}} - T_{\infty}] = \int_0^L h_x \cdot [T_{\text{wall}} - T_{\infty}] \cdot dx$$

Since the temperature difference is constant, it may be taken outside of the integral and cancelled:

$$h_L \cdot L = \int_0^L h_x \cdot dx$$

This is a general definition of an integrated average.

Proceed to substitute the correlation for the local coefficient.

$$h_L \cdot L = \int_0^L 0.323 \frac{k}{x} \left[ \frac{U_{\infty} \cdot x \cdot \rho}{\mu} \right]^{0.5} \cdot \text{Pr}^{1/3} \cdot dx$$

Take the constant terms from outside the integral, and divide both sides by k.

$$h_L \cdot L/k = 0.323 \cdot \left[ \frac{U_{\infty} \cdot \rho}{\mu} \right]^{0.5} \cdot \text{Pr}^{1/3} \cdot \int_0^L \left[ \frac{1}{x} \right]^{0.5} \cdot dx$$

Integrate the right side.

$$h_L \cdot L/k = 0.323 \cdot \left[ \frac{U_{\infty} \cdot \rho}{\mu} \right]^{0.5} \cdot \text{Pr}^{1/3} \cdot \left. \frac{x^{0.5}}{0.5} \right|_0^L$$

The left side is defined as the average Nusselt number, ( $\text{Nu}_L$ ). Algebraically rearrange the right side.

$$\text{Nu}_L = \frac{0.323}{0.5} \cdot \left[ \frac{U_{\infty} \cdot \rho}{\mu} \right]^{0.5} \cdot \text{Pr}^{1/3} \cdot L^{0.5} = 0.646 \cdot \left[ \frac{U_{\infty} \cdot L \cdot \rho}{\mu} \right]^{0.5} \cdot \text{Pr}^{1/3}$$

The term in the brackets may be recognized as the Reynolds number, evaluated at the end of the convective section. Finally,

$$\text{Nu}_L = 0.646 \cdot \text{Re}_L^{0.5} \cdot \text{Pr}^{1/3}$$

This is our average correlation for laminar flow over a flat plate with constant wall temperature.

## Reynolds Analogy

In the development of the boundary layer theory, one may notice the strong relationship between the dynamic boundary layer and the thermal boundary layer. Reynolds's noted the strong correlation and found that fluid friction and convection coefficient could be related. This refers to the Reynolds Analogy.

$$\text{Pr} = 1, \quad \text{Stanton number} = \frac{C_f}{2}$$

**Conclusion from Reynolds's analogy:** Knowing the frictional drag, we know the Nusselt Number. If the drag coefficient is increased, say through increased wall roughness,

then the convective coefficient will increase. If the wall friction is decreased, the convective coefficient is decreased.

⇒ Laminar, fully developed circular pipe flow:

$$N_s'' = hA(T_s - T_n)$$

$$Nu_D = \frac{hD}{k_f} = 4.36 \quad \text{when } q_s'' = \text{constant}$$

$$h = \frac{48}{11} \frac{k}{D}$$

[VIMP]

⇒ Fully developed turbulent pipe flow

$$Nu_D = 0.023 Re^{0.8} Pr^n$$

$$n = 0.4 \text{ for heating}$$

$$n = 0.3 \text{ for cooling}$$

## Turbulent Flow

We could develop a turbulent heat transfer correlation in a manner similar to the **von Karman analysis**. It is probably easier, having developed the Reynolds analogy, to follow that course. The local fluid friction factor,  $C_f$ , associated with turbulent flow over a flat plate is given as:

$$C_f = 0.0592 / Re_x^{0.2}$$

Substitute into the Reynolds analogy:

$$(0.0592 / Re_x^{0.2}) / 2 = Nu_x / Re_x Pr^{1/3}$$

Rearrange to find

$$Nu_x = 0.0296 Re_x^{0.8} Pr^{1/3}$$

Local Correlation  
Turbulent Flow  
Flat Plate

In order to develop an average correlation, one would evaluate an integral along the plate similar to that used in a laminar flow:

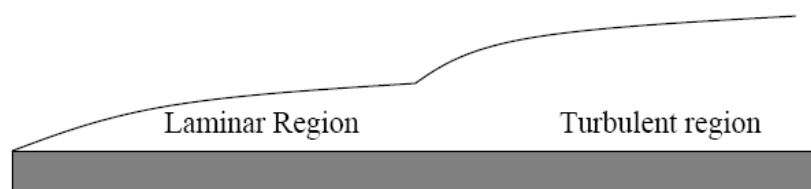

$$h_L \cdot L = \int_0^L h_x dx = \int_0^{L_{crit}} h_{x, \text{laminar}} \cdot dx + \int_{L_{crit}}^L h_{x, \text{turbulent}} \cdot dx$$

**Note:** The critical Reynolds number for flow over a flat plate is  $5 \times 10^5$ ; the critical Reynolds number for flow through a round tube is **2000**.

The result of the above integration is:

$$Nu_x = 0.037 \cdot (Re_x^{0.8} - 871) \cdot Pr^{1/3}$$

**Note:** Fluid properties should be evaluated at the average temperature in the boundary layer, i.e. at an average between the wall and free stream temperature.

$$T_{prop} = 0.5 \cdot (T_{wall} + T_{\infty})$$

## Free Convection

Free convection is sometimes defined as a convective process in which fluid motion is caused by buoyancy effects.

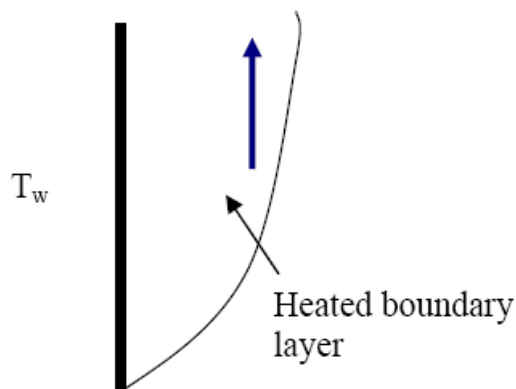

$$T_{\infty} < T_{\text{boundary layer}} < T_w$$

$$\rho_{\infty} < \rho \text{ Boundary layer}$$

## Velocity Profiles

Compare the velocity profiles for forced and natural convection shown figure:

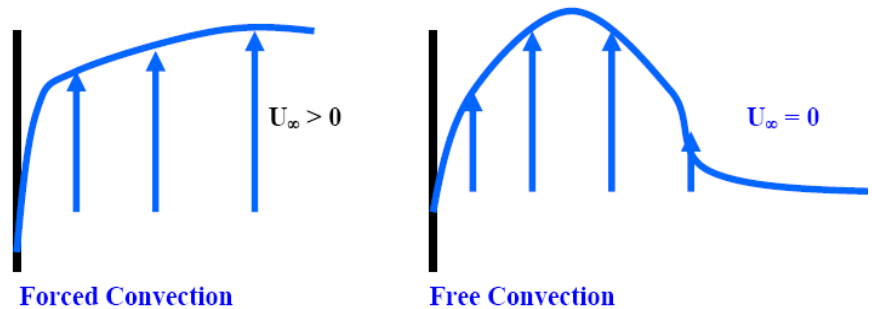

## Coefficient of Volumetric Expansion

The thermodynamic property which describes the change in density leading to buoyancy in The **Coefficient of Volumetric Expansion, ( $\beta$ )**.

$$\beta \equiv -\frac{1}{\rho} \cdot \frac{\partial \rho}{\partial T_{P=Const.}}$$

## Evaluation of $\beta$

- **Liquids and Solids:**  $\beta$  is a thermodynamic property and should be found from Property Tables. Values of  $\beta$  are found for a number of engineering fluids.

- **Ideal Gases:** We may develop a general expression for  $\beta$  for an ideal gas from the Ideal gas law:

Then,

$$P = \rho.R.T$$

$$\rho = P/R.T$$

Differentiating while holding P constant:

$$\left. \frac{d\rho}{dT} \right|_{p-Const.} = -\frac{P}{R.T^2} = -\frac{\rho.R.T}{R.T^2} = -\frac{\rho}{T}$$

Substitute into the definition of  $\beta$

$$\beta = \frac{1}{T_{abs}}$$

Ideal Gas

## Grashof Number

Because  $U_\infty$  is always zero, the Reynolds number,  $[\rho \cdot U_\infty \cdot D]/\mu$ , is also zero and is no longer suitable to describe the flow in the system. Instead, we introduce a new parameter for natural convection, the Grashof Number. Here we will be most concerned with flow across a vertical surface, so that we use the vertical distance,  $z$  or  $L$ , as the characteristic length.

$$Gr \equiv \frac{g \cdot \beta \cdot \Delta T \cdot L^3}{\nu^2}$$

Just as we have looked at the Reynolds number for a physical meaning, we may consider the Grashof number:

$$Gr \equiv \frac{\rho^2 \cdot g \cdot \beta \cdot \Delta T \cdot L^3}{\mu^2} = \frac{\left( \frac{\rho \cdot g \cdot \beta \cdot \Delta T \cdot L^3}{L^2} \right) \cdot (\rho \cdot U_{max}^2)}{\mu^2 \cdot \frac{U_{max}^2}{L^2}}$$

$$= \frac{\left( \frac{\text{Buoyant Force}}{\text{Area}} \right) \cdot \left( \frac{\text{Momentum}}{\text{Area}} \right)}{\left( \frac{\text{Viscous Force}}{\text{Area}} \right)^2}$$

## Free Convection Heat Transfer Correlations

The standard form for free, or natural, convection correlations will appear much like those for forced convection except that (1) the Reynolds number is replaced with a Grashof

number and (2) the exponent on Prandtl number is not generally 1/3 (The von Karman boundary layer analysis from which we developed the 1/3 exponent was for forced convection flows):

$$Nu_x = C.Gr_x^m . Pr^n \quad \text{Local Correlation.}$$

$$Nu_L = C.Gr_L^m . Pr^n \quad \text{Average Correlation.}$$

Quite often experimentalists find that the exponent on the Grashof and Prandtl numbers are equal so that the general correlations may be written in the form:

$$Nu_x = C \cdot [Gr_x . Pr]^m \quad \text{Local Correlation}$$

$$Nu_L = C \cdot [Gr_L . Pr]^m \quad \text{Average Correlation}$$

This leads to the introduction of the new, dimensionless parameter, the Rayleigh number, Ra:

$$Ra_x = Gr_x . Pr$$

$$Ra_L = Gr_L . Pr$$

So, that the general correlation for free convection becomes:

$$Nu_x = C \cdot Ra_x^m \quad \text{Local Correlation}$$

$$Nu_L = C \cdot Ra_L^m \quad \text{Average Correlation}$$

### Laminar to Turbulent Transition

Just as for forced convection, a boundary layer will form for free convection. The insulating film will be relatively thin toward the leading edge of the surface resulting in a relatively high convection coefficient. At a Rayleigh number of about  $10^9$  the flow over a flat plate will transition to a turbulent pattern. The increased turbulence inside the boundary layer will enhance heat transfer leading to relative high convection coefficients, much like forced convection.

$$Ra < 10^9 \text{ Laminar flow [Vertical Flat Plate]}$$

$$Ra > 10^9 \text{ Turbulent flow [Vertical Flat Plate]}$$

Generally the characteristic length used in the correlation relates to the distance over which the boundary layer is allowed to grow. In the case of a vertical flat plate this will be  $x$  or  $L$ , in the case of a vertical cylinder this will also be  $x$  or  $L$ ; in the case of a

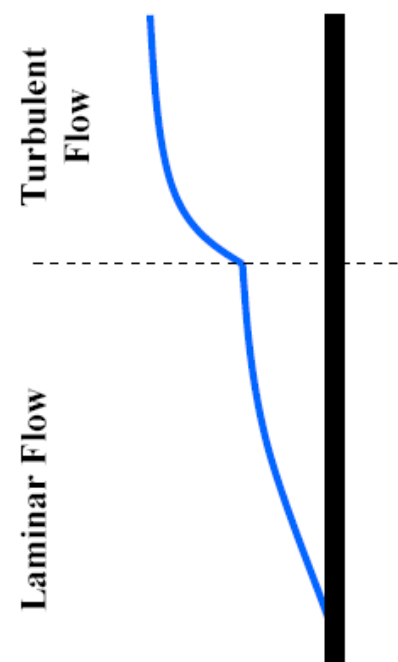

horizontal cylinder, the length will be  $d$ .

### Critical Rayleigh Number

Consider the flow between two surfaces, each at different temperatures. Under developed flow conditions, the interstitial fluid will reach a temperature between the temperatures of the two surfaces and will develop free convection flow patterns. The fluid will be heated by one surface, resulting in an upward buoyant flow, and will be cooled by the other, resulting in a downward flow.

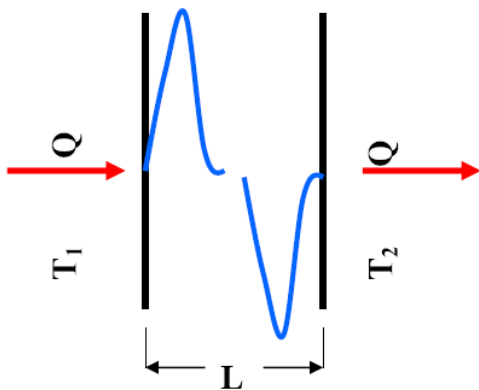

Note that for enclosures it is customary to develop correlations which describe the overall (both heated and cooled surfaces) within a single correlation.

Free Convection Inside and Enclosure

If the surfaces are placed closer together, the flow patterns will begin to interfere:

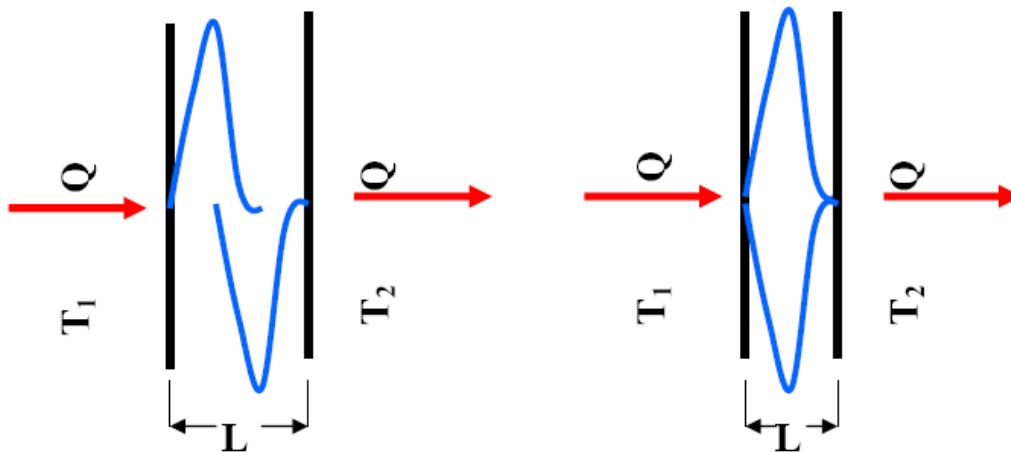

Free Convection Inside an Enclosure with Partial Flow Interference

Free Convection Inside an Enclosure with Complete Flow Interference

In the case of complete flow interference, the upward and downward forces will cancel, cancelling circulation forces. This case would be treated as a pure convection problem since no bulk transport occurs.



The transition in enclosures from convection heat transfer to conduction heat transfer occurs at what is termed the “Critical Rayleigh Number”. Note that this terminology is in clear contrast to forced convection where the critical Reynolds number refers to the transition from laminar to turbulent flow.

$$Ra_{crit} = 1000 \text{ (Enclosures with Horizontal Heat Flow)}$$

$$Ra_{crit} = 1728 \text{ (Enclosures with Vertical Heat Flow)}$$

The existence of a Critical Rayleigh number suggests that there are now three flow regimes: (1) **No flow**, (2) **Laminar Flow** and (3) **Turbulent Flow**. In all enclosure problems the Rayleigh number will be calculated to determine the proper flow regime before a correlation is chosen.

### Bulk Temperature

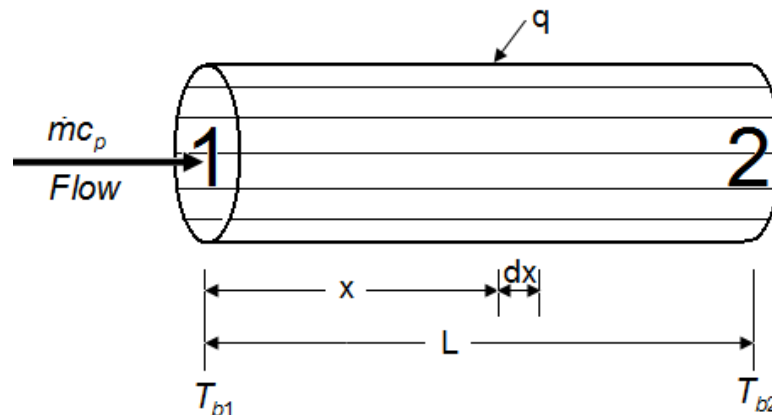

$$Q = \dot{m}c_p (T_{b2} - T_{b1})$$

$$dQ = \dot{m}c_p dT_b = h \{2\pi r dr (T_w - T_b)\}$$

- The bulk temperature represents energy average or ‘mixing cup’ conditions.
- The total energy ‘exchange’ in a tube flow can be expressed in terms of a bulk temperature difference.

**Bulk-mean temperature** =  $\frac{\text{total thermal energy crossing a section pipe in unit time}}{\text{heat capacity of fluid crossing same section in unit time}}$

$$= \frac{\int_0^{r_o} u(r)T(r)rdr}{u_m \int_0^{r_o} rdr} = \frac{2}{u_m r_o^2} \int_0^{r_o} u(r)T(r)rdr$$

## OBJECTIVE QUESTIONS (GATE, IES, IAS)

## Previous 20-Years GATE Questions

**GATE-1.** A coolant fluid at  $30^\circ\text{C}$  flows over a heated flat plate maintained at a constant temperature of  $100^\circ\text{C}$ . The boundary layer temperature distribution at a given location on the plate may be approximated as  $T = 30 + 70\exp(-y)$  where  $y$  (in  $m$ ) is the distance normal to the plate and  $T$  is in  $^\circ\text{C}$ . If thermal conductivity of the fluid is  $1.0 \text{ W/mK}$ , the local convective heat transfer coefficient (in  $\text{W/m}^2\text{K}$ ) at that location will be:

[GATE-2009]

- (a) 0.2                      (b) 1                      (c) 5                      (d) 10

**GATE-2.** The properties of mercury at  $300 \text{ K}$  are: density =  $13529 \text{ kg/m}^3$ , specific heat at constant pressure =  $0.1393 \text{ kJ/kg-K}$ , dynamic viscosity =  $0.1523 \times 10^{-2} \text{ N.s/m}^2$  and thermal conductivity =  $8.540 \text{ W/mK}$ . The Prandtl number of the mercury at  $300 \text{ K}$  is:

[GATE-2002]

- (a) 0.0248                      (b) 2.48                      (c) 24.8                      (d) 248

**GATE-3.** The average heat transfer coefficient on a thin hot vertical plate suspended in still air can be determined from observations of the change in plate temperature with time as it cools. Assume the plate temperature to be uniform at any instant of time and radiation heat exchange with the surroundings negligible. The ambient temperature is  $25^\circ\text{C}$ , the plate has a total surface area of  $0.1 \text{ m}^2$  and a mass of  $4 \text{ kg}$ . The specific heat of the plate material is  $2.5 \text{ kJ/kgK}$ . The convective heat transfer coefficient in  $\text{W/m}^2\text{K}$ , at the instant when the plate temperature is  $225^\circ\text{C}$  and the change in plate temperature with time  $dT/dt = -0.02 \text{ K/s}$ , is:

[GATE-2007]

- (a) 200                      (b) 20                      (c) 15                      (d) 10

Data for Q4–Q5 are given below. Solve the problems and choose correct answers.

Heat is being transferred by convection from water at  $48^\circ\text{C}$  to a glass plate whose surface that is exposed to the water is at  $40^\circ\text{C}$ . The thermal conductivity of water is  $0.6 \text{ W/mK}$  and the thermal conductivity of glass is  $1.2 \text{ W/mK}$ . The spatial Water gradient of temperature in the water at the water-glass interface is  $dT/dy = 1 \times 10^4 \text{ K/m}$ .

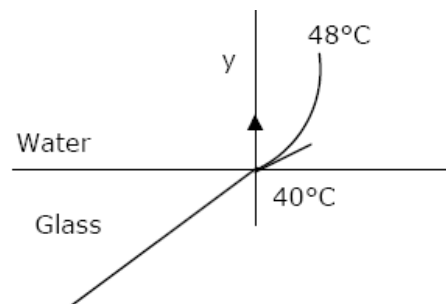

[GATE-2003]

**GATE-4.** The value of the temperature gradient in the glass at the water-glass interface in  $\text{k/m}$  is:

- (a)  $-2 \times 10^4$                       (b) 0.0                      (c)  $0.5 \times 10^4$                       (d)  $2 \times 10^4$

**GATE-5.** The heat transfer coefficient  $h$  in  $\text{W/m}^2\text{K}$  is:

- (a) 0.0                      (b) 4.8                      (c) 6                      (d) 750

- GATE-6.** If velocity of water inside a smooth tube is doubled, then turbulent flow heat transfer coefficient between the water and the tube will: [GATE-1999]
- Remain unchanged
  - Increase to double its value
  - Increase but will not reach double its value
  - Increase to more than double its value

## Previous 20-Years IES Questions

- IES-1.** A sphere, a cube and a thin circular plate, all made of same material and having same mass are initially heated to a temperature of 250°C and then left in air at room temperature for cooling. Then, which one of the following is correct? [IES-2008]
- All will be cooled at the same rate
  - Circular plate will be cooled at lowest rate
  - Sphere will be cooled faster
  - Cube will be cooled faster than sphere but slower than circular plate
- IES-2.** A thin flat plate 2 m by 2 m is hanging freely in air. The temperature of the surroundings is 25°C. Solar radiation is falling on one side of the plate at the rate of 500 W/m<sup>2</sup>. The temperature of the plate will remain constant at 30°C, if the convective heat transfer coefficient (in W/m<sup>2</sup> °C) is: [IES-1993]
- 25
  - 50
  - 100
  - 200
- IES-3.** Air at 20°C blows over a hot plate of 50 × 60 cm made of carbon steel maintained at 220°C. The convective heat transfer coefficient is 25 W/m<sup>2</sup>K. What will be the heat loss from the plate? [IES-2009]
- 1500W
  - 2500 W
  - 3000 W
  - 4000 W
- IES-4.** For calculation of heat transfer by natural convection from a horizontal cylinder, what is the characteristic length in Grashof Number? [IES-2007]
- Diameter of the cylinder
  - Length of the cylinder
  - Circumference of the base of the cylinder
  - Half the circumference of the base of the cylinder
- IES-5.** Assertion (A): For the similar conditions the values of convection heat transfer coefficients are more in forced convection than in free convection. [IES-2009]  
Reason (R): In case of forced convection system the movement of fluid is by means of external agency.
- Both A and R are individually true and R is the correct explanation of A
  - Both A and R individually true but R is not the correct explanation of A
  - A is true but R is false

(d) A is false but R is true

- IES-6.** Assertion (A): A slab of finite thickness heated on one side and held horizontal will lose more heat per unit time to the cooler air if the hot surface faces upwards when compared with the case where the hot surface faces downwards. [IES-1996]  
Reason (R): When the hot surface faces upwards, convection takes place easily whereas when the hot surface faces downwards, heat transfer is mainly by conduction through air.  
(a) Both A and R are individually true and R is the correct explanation of A  
(b) Both A and R are individually true but R is **not** the correct explanation of A  
(c) A is true but R is false  
(d) A is false but R is true
- IES-7.** For the fully developed laminar flow and heat transfer in a uniformly heated long circular tube, if the flow velocity is doubled and the tube diameter is halved, the heat transfer coefficient will be: [IES-2000]  
(a) Double of the original value (b) Half of the original value  
(c) Same as before (d) Four times of the original value
- IES-8.** Assertion (A): According to Reynolds analogy for Prandtl number equal to unity, Stanton number is equal to one half of the friction factor.  
Reason (R): If thermal diffusivity is equal to kinematic viscosity, the velocity and the temperature distribution in the flow will be the same.  
(a) Both A and R are individually true and R is the correct explanation of A  
(b) Both A and R are individually true but R is **not** the correct explanation of A  
(c) A is true but R is false [IES-2001]  
(d) A is false but R is true
- IES-9.** The Nusselt number is related to Reynolds number in laminar and turbulent flows respectively as [IES-2000]  
(a)  $Re^{-1/2}$  and  $Re^{0.8}$  (b)  $Re^{1/2}$  and  $Re^{0.8}$  (c)  $Re^{-1/2}$  and  $Re^{-0.8}$  (d)  $Re^{1/2}$  and  $Re^{-0.8}$
- IES-10.** In respect of free convection over a vertical flat plate the Nusselt number varies with Grashof number 'Gr' as [IES-2000]  
(a) Gr and  $Gr^{1/4}$  for laminar and turbulent flows respectively  
(b)  $Gr^{1/2}$  and  $Gr^{1/3}$  for laminar and turbulent flows respectively  
(c)  $Gr^{1/4}$  and  $Gr^{1/3}$  for laminar and turbulent flows respectively  
(d)  $Gr^{1/3}$  and  $Gr^{1/4}$  for laminar and turbulent flows respectively
- IES-11.** Heat is lost from a 100 mm diameter steam pipe placed horizontally in ambient at 30°C. If the Nusselt number is 25 and thermal conductivity of air is 0.03 W/mK, then the heat transfer co-efficient will be: [IES-1999]  
(a) 7.5 W/m<sup>2</sup>K (b) 16.2 W/m<sup>2</sup>K (c) 25.2 W/m<sup>2</sup>K (d) 30 W/m<sup>2</sup>K
- IES-12.** Match List-I (Non-dimensional number) with List-II (Application) and select the correct answer using the code given below the lists:  
List-I List-II [IES 2007]  
A. Grashof number 1. Mass transfer  
B. Stanton number 2. Unsteady state heat conduction  
C. Sherwood number 3. Free convection  
D. Fourier number 4. Forced convection  
Codes: A B C D A B C D

(a)	4	3	1	2	(b)	3	4	1	2
(c)	4	3	2	1	(d)	3	4	2	1

**IES-13. Match List-I (Type of heat transfer) with List-II (Governing dimensionless parameter) and select the correct answer: [IES-2002]**

<b>List-I</b>					<b>List-II</b>				
A.	Forced convection				1.	Reynolds, Grashof and Prandtl number			
B.	Natural convection				2.	Reynolds and Prandtl number			
C.	Combined free and forced convection				3.	Fourier modulus and Biot number			
D.	Unsteady conduction with convection at surface				4.	Prandtl number and Grashof number			
<b>Codes:</b>	<b>A</b>	<b>B</b>	<b>C</b>	<b>D</b>	<b>A</b>	<b>B</b>	<b>C</b>	<b>D</b>	
(a)	2	1	4	3	(b)	3	4	1	2
(c)	2	4	1	3	(d)	3	1	4	2

**IES-14. Match List-I (Phenomenon) with List-II (Associated dimensionless parameter) and select the correct answer using the code given below the lists: [IES-2006]**

<b>List-I</b>					<b>List-II</b>				
A.	Transient conduction				1.	Reynolds number			
B.	Forced convection				2.	Grashoff number			
C.	Mass transfer				3.	Biot number			
D.	Natural convection				4.	Mach number			
					5.	Sherwood number			
<b>Codes:</b>	<b>A</b>	<b>B</b>	<b>C</b>	<b>D</b>	<b>A</b>	<b>B</b>	<b>C</b>	<b>D</b>	
(a)	3	2	5	1	(b)	5	1	4	2
(c)	3	1	5	2	(d)	5	2	4	1

**IES-15. Match List-I (Process) with List-II (Predominant parameter associated with the flow) and select the correct answer: [IES-2004]**

<b>List-I</b>					<b>List-II</b>				
A.	Transient conduction				1.	Sherwood Number			
B.	Mass transfer				2.	Mach Number			
C.	Forced convection				3.	Biot Number			
D.	Free convection				4.	Grashof Number			
					5.	Reynolds number			
<b>Codes:</b>	<b>A</b>	<b>B</b>	<b>C</b>	<b>D</b>	<b>A</b>	<b>B</b>	<b>C</b>	<b>D</b>	
(a)	1	3	5	4	(b)	3	1	2	5
(c)	3	1	5	4	(d)	1	3	2	5

**IES-16. Which one of the following non-dimensional numbers is used for transition from laminar to turbulent flow in free convection? [IES-2007]**

- |                     |                     |
|---------------------|---------------------|
| (a) Reynolds number | (b) Grashof number  |
| (c) Peclet number   | (d) Rayleigh number |

**IES-17. Match List-I (Process) with List-II (Predominant parameter associated with the process) and select the correct answer using the codes given below the lists: [IES-2003]**

<b>List-I</b>		<b>List-II</b>	
A.	Mass transfer	1.	Reynolds Number
B.	Forced convection	2.	Sherwood Number

- C. Free convection  
D. Transient conduction

3. Mach Number  
4. Biot Number  
5. Grashoff Number

Codes:	A	B	C	D	A	B	C	D
(a)	5	1	2	3	(b)	2	1	5
(c)	4	2	1	3	(d)	2	3	5

IES-18. In free convection heat transfer transition from laminar to turbulent flow is governed by the critical value of the [IES-1992]  
 (a) Reynolds number (b) Grashoff's number  
 (c) Reynolds number, Grashoff number (d) Prandtl number, Grashoff number

IES-19. Nusselt number for fully developed turbulent flow in a pipe is given by  $N_u = CR_e^a P_r^b$ . The values of  $a$  and  $b$  are: [IES-2001]  
 (a)  $a = 0.5$  and  $b = 0.33$  for heating and cooling both  
 (b)  $a = 0.5$  and  $b = 0.4$  for heating and  $b = 0.3$  for cooling  
 (c)  $a = 0.8$  and  $b = 0.4$  for heating and  $b = 0.3$  for cooling  
 (d)  $a = 0.8$  and  $b = 0.3$  for heating and  $b = 0.4$  for cooling

IES-20. For natural convective flow over a vertical flat plate as shown in the given figure, the governing differential equation for momentum is:

$$\left( u \frac{\partial u}{\partial x} + v \frac{\partial u}{\partial y} \right) = g\beta(T - T_\infty) + y \frac{\partial^2 u}{\partial y^2}$$

If equation is non-dimensionalized by

$$U = \frac{u}{U_\infty}, X = \frac{x}{L}, Y = \frac{y}{L} \text{ and } \theta = \frac{T - T_\infty}{T_s - T_\infty}$$

then the term  $g\beta(T - T_\infty)$ , is equal to:

- (a) Grashof number (b) Prandtl number  
 (c) Rayleigh number (d)  $\frac{\text{Grashof number}}{(\text{Reynolds number})^2}$

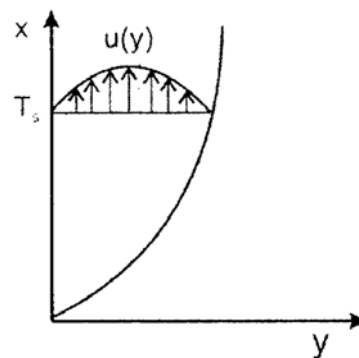

[IES-2001]

IES-21. Which one of the following numbers represents the ratio of kinematic viscosity to the thermal diffusivity? [IES-2005]

- (a) Grashoff number (b) Prandtl number  
 (c) Mach number (d) Nusselt number

IES-22. Nusselt number for a pipe flow heat transfer coefficient is given by the equation  $Nu_D = 4.36$ . Which one of the following combinations of conditions does exactly apply for use of this equation? [IES-2004]

- (a) Laminar flow and constant wall temperature  
 (b) Turbulent flow and constant wall heat flux  
 (c) Turbulent flow and constant wall temperature  
 (d) Laminar flow and constant wall heat flux

IES-23. For steady, uniform flow through pipes with constant heat flux supplied to the wall, what is the value of Nusselt number? [IES-2007]

- (a) 48/11 (b) 11/48 (c) 24/11 (d) 11/24

IES-24. A fluid of thermal conductivity 1.0 W/m-K flows in fully developed flow with Reynolds number of 1500 through a pipe of diameter 10 cm. The

heat transfer coefficient for uniform heat flux and uniform wall temperature boundary conditions are, respectively. [IES-2002]

- (a)  $36.57$  and  $43.64 \frac{\text{W}}{\text{m}^2\text{K}}$  (b)  $43.64$  and  $36.57 \frac{\text{W}}{\text{m}^2\text{K}}$   
 (c)  $43.64 \frac{\text{W}}{\text{m}^2\text{K}}$  for both the cases (d)  $36.57 \frac{\text{W}}{\text{m}^2\text{K}}$  for both the cases

IES-25. Which one of the following statements is correct? [IES-2004]  
 The non-dimensional parameter known as Stanton number (St) is used in

- (a) Forced convection heat transfer in flow over flat plate  
 (b) Condensation heat transfer with laminar film layer  
 (c) Natural convection heat transfer over flat plate  
 (d) Unsteady heat transfer from bodies in which internal temperature gradients cannot be neglected

IES-26. A 320 cm high vertical pipe at  $150^\circ\text{C}$  wall temperature is in a room with still air at  $10^\circ\text{C}$ . This pipe supplies heat at the rate of 8 kW into the room air by natural convection. Assuming laminar flow, the height of the pipe needed to supply 1 kW only is: [IES-2002]

- (a) 10 cm (b) 20 cm (c) 40 cm (d) 80 cm

IES-27. Natural convection heat transfer coefficients over surface of a vertical pipe and vertical flat plate for same height and fluid are equal. What is/are the possible reasons for this? [IES-2008]

1. Same height 2. Both vertical  
 3. Same fluid 4. Same fluid flow pattern

Select the correct answer using the code given below:

- (a) 1 only (b) 1 and 2 (c) 3 and 4 (d) 4 only

IES-28. The average Nusselt number in laminar natural convection from a vertical wall at  $180^\circ\text{C}$  with still air at  $20^\circ\text{C}$  is found to be 48. If the wall temperature becomes  $30^\circ\text{C}$ , all other parameters remaining same, the average Nusselt number will be: [IES-2002]

- (a) 8 (b) 16 (c) 24 (d) 32

IES-29. For fully-developed turbulent flow in a pipe with heating, the Nusselt number  $Nu$ , varies with Reynolds number  $Re$  and Prandtl number  $Pr$  as [IES-2003]

- (a)  $Re^{0.5} Pr^{\frac{1}{3}}$  (b)  $Re^{0.8} Pr^{0.2}$  (c)  $Re^{0.8} Pr^{0.4}$  (d)  $Re^{0.8} Pr^{0.3}$

IES-30. For laminar flow over a flat plate, the local heat transfer coefficient ' $h_x$ ' varies as  $x^{-1/2}$ , where  $x$  is the distance from the leading edge ( $x = 0$ ) of the plate. The ratio of the average coefficient ' $h_a$ ' between the leading edge and some location ' $A$ ' at  $x = x$  on the plate to the local heat transfer coefficient ' $h_x$ ' at  $A$  is: [IES-1999]

- (a) 1 (b) 2 (c) 4 (d) 8

IES-31. When there is a flow of fluid over a flat plate of length ' $L$ ', the average heat transfer coefficient is given by ( $Nu_x =$  Local Nusselt number; other symbols have the usual meaning) [IES-1997]

(a)  $\int_0^L h_x dx$

(b)  $\frac{d}{dx}(h_x)$

(c)  $\frac{1}{L} \int_0^L h_x dx$

(d)  $\frac{k}{L} \int_0^L Nu_x dx$

IES-32. In the case of turbulent flow through a horizontal isothermal cylinder of diameter 'D', free convection heat transfer coefficient from the cylinder will: [IES-1997]

- (a) Be independent of diameter (b) Vary as  $D^{3/4}$   
 (c) Vary as  $D^{1/4}$  (d) Vary as  $D^{1/2}$

IES-33. Match List-I (Dimensionless quantity) with List-II (Application) and select the correct answer using the codes given below the lists:

- List-I**  
 A. Stanton number  
 B. Grashof number  
 C. Peclet number  
 D. Schmidt number

- List-II** [IES-1993]  
 1. Natural convection for ideal gases  
 2. Mass transfer  
 3. Forced convection  
 4. Forced convection for small Prandtl number

<b>Codes:</b>	<b>A</b>	<b>B</b>	<b>C</b>	<b>D</b>		<b>A</b>	<b>B</b>	<b>C</b>	<b>D</b>
(a)	2	4	3	1	(b)	3	1	4	2
(c)	3	4	1	2	(d)	2	1	3	4

IES-34. Assertion (A): All analyses of heat transfer in turbulent flow must eventually rely on experimental data. [IES-2000]

Reason (R): The eddy properties vary across the boundary layer and no adequate theory is available to predict their behaviour.

- (a) Both A and R are individually true and R is the correct explanation of A  
 (b) Both A and R are individually true but R is not the correct explanation of A  
 (c) A is true but R is false  
 (d) A is false but R is true

IES-35.

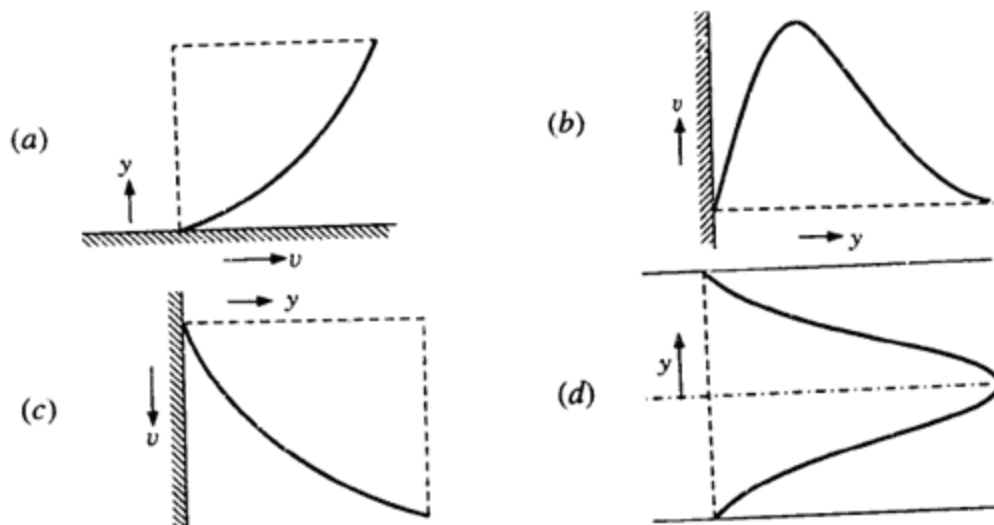

Match the velocity profiles labelled A, B, C and D with the following situations: [IES-1998]

1. Natural convection  
 2. Condensation  
 3. Forced convection  
 4. Bulk viscosity  $\neq$  wall viscosity  
 5. Flow in pipe entrance



Select the correct answer using the codes given below:

Codes:	A	B	C	D	A	B	C	D	
(a)	3	2	1	5	(b)	1	4	2	3
(c)	3	2	1	4	(d)	2	1	5	3

IES-36. Consider the following statements: [IES-1997]

If a surface is pock-marked with a number of cavities, then as compared to a smooth surface.

- |                             |                                   |
|-----------------------------|-----------------------------------|
| 1. Radiation will increase  | 2. Nucleate boiling will increase |
| 3. Conduction will increase | 4. Convection will increase       |

Of these statements:

- |                            |                            |
|----------------------------|----------------------------|
| (a) 1, 2 and 3 are correct | (b) 1, 2 and 4 are correct |
| (c) 1, 3 and 4 are correct | (d) 2, 3 and 4 are correct |

IES-37. A cube at high temperature is immersed in a constant temperature bath. It loses heat from its top, bottom and side surfaces with heat transfer coefficient of  $h_1$ ,  $h_2$  and  $h_3$  respectively. The average heat transfer coefficient for the cube is: [IES-1996]

- |                       |                           |   |                       |
|-----------------------|---------------------------|---|-----------------------|
| (a) $h_1 + h_2 + h_3$ | (b) $(h_1 h_2 h_3)^{1/3}$ | (c) $\frac{1}{h_1} + \frac{1}{h_2} + \frac{1}{h_3}$ | (d) None of the above |
|-----------------------|---------------------------|---|-----------------------|

IES-38. Assertion (A): When heat is transferred from a cylinder in cross flow to an air stream, the local heat transfer coefficient at the forward stagnation point is large. [IES-1995]

Reason (R): Due to separation of the boundary layer eddies continuously sweep the surface close to the forward stagnation point.

- |   |
|---|
| (a) Both A and R are individually true and R is the correct explanation of A            |
| (b) Both A and R are individually true but R is <b>not</b> the correct explanation of A |
| (c) A is true but R is false  |
| (d) A is false but R is true  |

IES-39. Match List-I (Flow pattern) with List-II (Situation) and select the correct answer using the codes given below the lists: [IES-1995]

List-I

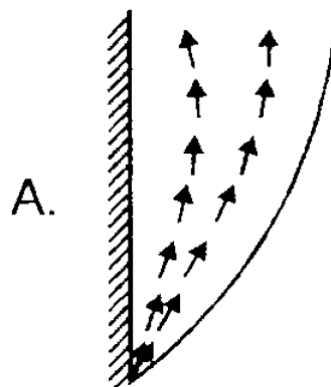

List-II

1. Heated horizontal plate

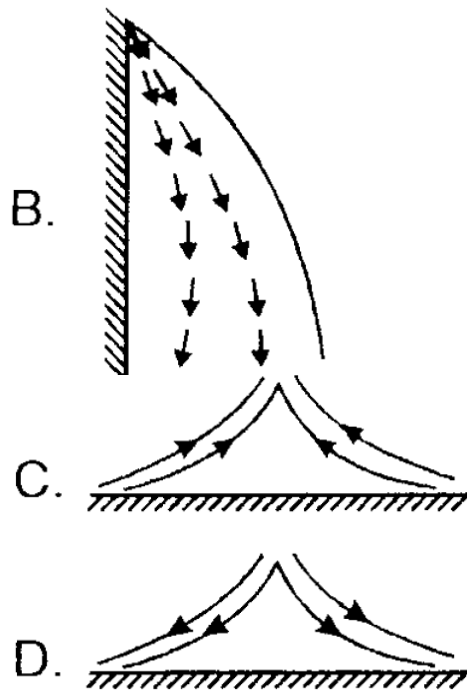

2. Cooled horizontal plate

3. Heated vertical plate

4. Cooled vertical plate

Codes:	A	B	C	D	A	B	C	D	
(a)	4	3	2	1	(b)	3	4	1	2
(c)	3	4	2	1	(d)	4	3	1	2

**IES-40.** Consider a hydrodynamically fully developed flow of cold air through a heated pipe of radius  $r_o$ . The velocity and temperature distributions in the radial direction are given by  $u(r)$  and  $T(r)$  respectively. If  $u_m$ , is the mean velocity at any section of the pipe, then the bulk-mean temperature at that section is given by: [IES-1994]

- |  |   |
|--|---|
| (a) $\int_0^{r_o} u(r)T(r)r^2 dr$                  | (b) $\int_0^{r_o} \frac{u(r)}{3r} \frac{T(r)}{2r} dr$ |
| (c) $\frac{4 \int_0^{r_o} u(r)T(r)dr}{2\pi r_o^3}$ | (d) $\frac{2}{u_m r_o^2} \int_0^{r_o} u(r)T(r)r dr$   |

**IES-41.** The velocity and temperature distribution in a pipe flow are given by  $u(r)$  and  $T(r)$ . If  $u_m$  is the mean velocity at any section of the pipe, the bulk mean temperature at that section is: [IES-2003]

- |   |   |
|---|---|
| (a) $\int_0^{r_o} u(r)T(r)r^2 dr$                 | (b) $\int_0^{r_o} \frac{u(r)}{3r} \frac{T(r)}{2r} dr$ |
| (c) $\int_0^{r_o} \frac{u(r)T(r)}{2\pi r_o^3} dr$ | (d) $\frac{2}{u_m r_o^2} \int_0^{r_o} u(r)T(r)r dr$   |

**IES-42.** The ratio of energy transferred by convection to that by conduction is called [IES-1992]

- |                    |                    |
|--------------------|--------------------|
| (a) Stanton number | (b) Nusselt number |
| (c) Biot number    | (d) Prelet number  |

**IES-43.** Free convection flow depends on all of the following EXCEPT

- (a) Density
- (b) Coefficient of viscosity [IES-1992]
- (c) Gravitational force
- (d) Velocity

## Answers with Explanation (Objective)

## Previous 20-Years GATE Answers

## GATE-1. Ans. (b)

$$\text{Given } T = 30 + 70 e^{-y} \quad \text{or} \quad \left( \frac{dT}{dy} \right)_{at y=0} = 0 + 70 \times e^{-y} \cdot (-1) = -70$$

We know that

$$-k_f \left( \frac{dT}{dy} \right)_{at y=0} = h(T_s - T_\infty) \quad \text{or} \quad h = \frac{70 \times 1}{(100 - 30)} = 1$$

$$\text{GATE-2. Ans. (a)} \quad P_r = \frac{\mu C_p}{k} = \frac{0.1523 \times 10^{-2} \times (0.1393 \times 1000)}{8.540} = 0.0248$$

$$\text{GATE-3. Ans. (d)} \quad Q = mc_p \frac{dT}{dt} = hA(t - t_s)$$

$$\text{or } 4 \times (2.5 \times 10^3) \times 0.02 = h \times 0.1 \times (225 - 25)$$

$$\text{GATE-4. Ans. (c)} \quad K_w = 0.6 \text{ W/mK}; \quad K_G = 1.2 \text{ W/mK}$$

The spatial gradient of temperature in water at the water-glass interface

$$= \left( \frac{dT}{dy} \right)_w = 1 \times 10^4 \text{ K/m}$$

At Water glass interface,

$$Q = K_w \left( \frac{dT}{dy} \right)_w = K_G \left( \frac{dT}{dy} \right)_G \quad \text{or} \quad \left( \frac{dT}{dy} \right)_G = \frac{K_w}{K_G} \left( \frac{dT}{dy} \right)_w = \frac{0.6}{1.2} \times 10^4 = 0.5 \times 10^4 \text{ K/m}$$

$$\text{GATE-5. Ans. (d)} \quad \text{Heat transfer per unit area } q = h(T_f - T_i)$$

$$\text{or } h = \frac{q}{T_f - T_i} = \frac{K_w \left( \frac{dT}{dy} \right)_w}{T_f - T_i} = \frac{0.6 \times 10^4}{(48 - 40)} = 750 \text{ W/m}^2\text{K}$$

$$\text{GATE-6. Ans. (c)} \quad \bar{h} = 0.023 \frac{k}{D} (\text{Re})^{0.8} (\text{Pr})^{\frac{1}{3}} = 0.023 \frac{k}{D} \left( \frac{\rho V D}{\mu} \right)^{0.8} \left( \frac{\mu c_p}{k} \right)^{\frac{1}{3}}$$

$$\text{So } \bar{h} \propto v^{0.8} \quad \text{and} \quad Q \propto \bar{h}. \quad \text{Therefore} \quad \frac{Q_2}{Q_1} = \left( \frac{v_2}{v_1} \right)^{0.8} = 2^{0.8} = 1.74$$

## Previous 20-Years IES Answers

## IES-1. Ans. (d)

$$\text{IES-2. Ans. (b)} \quad \text{Heat transfer by convection } Q = hA\Delta t$$

$$\text{or } 500 \times (2 \times 2) = 2 \times \{h \times (2 \times 2) \times (30 - 25)\} \quad \text{or } h = 50 \text{ W/m}^2\text{°C}$$

IES-3. Ans. (a) Convective Heat Loss will take place from the one side of the plate since it is written that air blows over the hot plate

$$\therefore Q = hA(T_1 - T_2) = 25 \times (0.5 \times 0.6) (220 - 20) = 25 \times (0.3) (200) = 1500 \text{ W}$$

**IES-4. Ans. (a)** Characteristic length used in the correlation relates to the distance over which the boundary layer is allowed to grow. In the case of a vertical flat plate this will be  $x$  or  $L$ , in the case of a vertical cylinder this will also be  $x$  or  $L$ ; in the case of a horizontal cylinder, the length will be  $d$ .

For a vertical plate  
Vertical Distance 'x'

$$Gr_x = \frac{\beta g \Delta T x^3}{\nu^2}$$

Characteristic length

(i) Horizontal plate =  
$$\frac{\text{Surface Area}}{\text{Perimeter of the plate}}$$

(ii) Horizontal Cylinder  
 $L = \text{Outside diameter}$

(iii) Vertical Cylinder  
 $L = \text{height}$

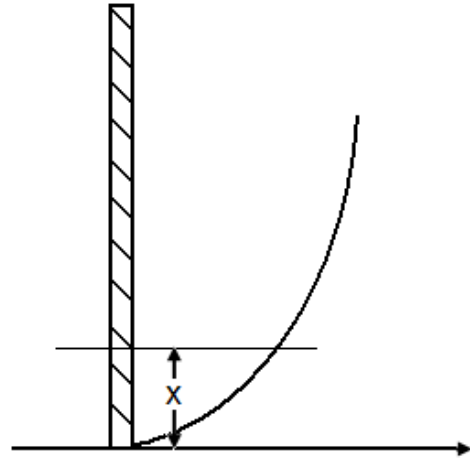

**IES-5. Ans. (a)** A free convection flow field is a self-sustained flow driven by the presence of a temperature gradient (as opposed to a forced convection flow where external means are used to provide the flow). As a result of the temperature difference, the density field is not uniform also. Buoyancy will induce a flow current due to the gravitational field and the variation in the density field. In general, a free convection heat transfer is usually much smaller compared to a forced convection heat transfer.

**IES-6. Ans. (a)** Both A and R are true, and R is correct explanation for A

**IES-7. Ans. (a) Reynolds Analogy:** There is strong relationship between the dynamic boundary layer and the thermal boundary layer. Reynold's noted the strong correlation and found that fluid friction and convection coefficient could be related.

**Conclusion from Reynold's analogy:** Knowing the frictional drag, we know the Nusselt number. If the drag coefficient is increased, say through increased wall roughness, then the convective coefficient will increase. If the wall friction is decreased, the convective co-efficient is decreased. For Turbulent Flow following relation may be used  $Nu_x = C(Re_x)^{0.8} (Pr)^{\frac{1}{3}}$ .

**IES-8. Ans. (d)**

**IES-9. Ans. (b)**

**IES-10. Ans. (c)**

**IES-11. Ans. (a)**  $\frac{hl}{k} = Nu_u$ , or  $h = \frac{25 \times 0.03}{0.1} = 7.5 \text{ W/m}^2\text{K}$

**IES-12. Ans. (b)**

**IES-13. Ans. (c)**

**IES-14. Ans. (c)**

**IES-15. Ans. (c)**

IES-16. Ans. (d) **Laminar to Turbulent**

**Transition:** Just as for forced convection, a boundary layer will form for free convection. The insulating film will be relatively thin toward the leading edge of the surface resulting in a relatively high convection coefficient. At a Rayleigh number of about  $10^9$  the flow over a flat plate will transition to a turbulent pattern. The increased turbulence inside the boundary layer will enhance heat transfer leading to relative high convection coefficients, much like forced convection.

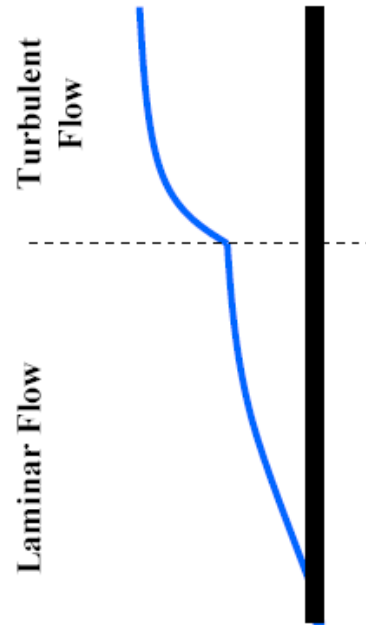

$Ra < 10^9$  Laminar flow [Vertical flat plate]  
 $Ra > 10^9$  Turbulent flow [Vertical flat plate]

IES-17. Ans. (b)

IES-18. Ans. (d)

IES-19. Ans. (c) Fully developed turbulent flow inside tubes (internal diameter D):

**Dittus-Boelter Equation:**

$$\text{Nusselt number, } Nu_D = \left( \frac{h_c D}{k_f} \right) = 0.023 Re_D^{0.8} Pr^n$$

where,  $n = 0.4$  for heating ( $T_w > T_f$ ) and  $n = 0.3$  for cooling ( $T_w < T_f$ ).

IES-20. Ans. (d)  $\frac{\text{Grashof number}}{(Re)^2}$ ; gives dimensionless number which signifies whether

flow is forced or free connection.

$$\frac{Gr}{Re^2} \ll 1; \text{ Forced convection}$$

$$\frac{Gr}{Re^2} \gg 1; \text{ Natural convection}$$

IES-21. Ans. (b)

IES-22. Ans. (d)

IES-23. Ans. (a)

IES-24. Ans. (b) For uniform heat flux:  $Nu_D = \frac{hD}{k} = 4.36$

For uniform wall temperature:  $Nu_D = \frac{hD}{k} = 3.66$

$$\frac{k}{D} = \frac{1}{0.1} = 10$$

IES-25. Ans. (a)

IES-26. Ans. (b) For vertical pipe characteristic dimension is the length of the pipe.

$$\text{For laminar flow } Nu = (Gr.Pr)^{1/4}$$

$h$  become independent of length

$$\frac{q_1}{q_2} = \frac{h_1 A \Delta T}{h_2 A \Delta T} \Rightarrow \frac{8}{1} = \frac{L_1}{L_2} \Rightarrow L_2 = 40 \text{ cm}$$

IES-27. Ans. (d) Same height, both vertical and same fluid everything

$$\text{IES-28. Ans. (c)} \quad \frac{Nu_2}{Nu_1} = \frac{\Delta t_2}{\Delta t_1} = \frac{60}{160} \quad \text{or } Nu_2 = 24$$

IES-29. Ans. (c)

IES-30. Ans. (b) Here at  $x = 0$ ,  $h_o = h$ , and at  $x = x$ ,  $h_x = \frac{h}{\sqrt{x}}$

$$\text{Average coefficient} = \frac{1}{x} \int_0^x \frac{h}{\sqrt{x}} dx = \frac{2h}{\sqrt{x}}$$

$$\text{Therefore ratio} = \frac{\frac{2h}{\sqrt{x}}}{\frac{h}{\sqrt{x}}} = 2$$

IES-31. Ans. (c)

IES-32. Ans. (a)

IES-33. Ans. (b) The correct matching for various dimensionless quantities is provided by code (b)

IES-34. Ans. (a)

IES-35. Ans. (a) It provides right matching

IES-36. Ans. (b) If coefficient of friction is increased radiation will decrease.

IES-37. Ans. (d)  $Q = (h_1 A \Delta T + h_2 A \Delta T + h_3 A \Delta T)$

$$Q = h_{av} \times 6 A \Delta T; \quad \therefore h_{av} = \frac{h_1 + h_2 + 4h_3}{6}$$

IES-38. Ans. (b)

IES-39. Ans. (b)

IES-40. Ans. (d) Bulk-mean temperature =

$\frac{\text{Total thermal energy crossing a section pipe in unit time}}{\text{Heat capacity of fluid crossing same section in unit time}}$

$$= \frac{\int_0^{r_o} u(r) T(r) r dr}{u_m \int_0^{r_o} r dr} = \frac{2}{u_m r_o^2} \int_0^{r_o} u(r) T(r) r dr$$

IES-41. Ans. (d) Bulk temperature

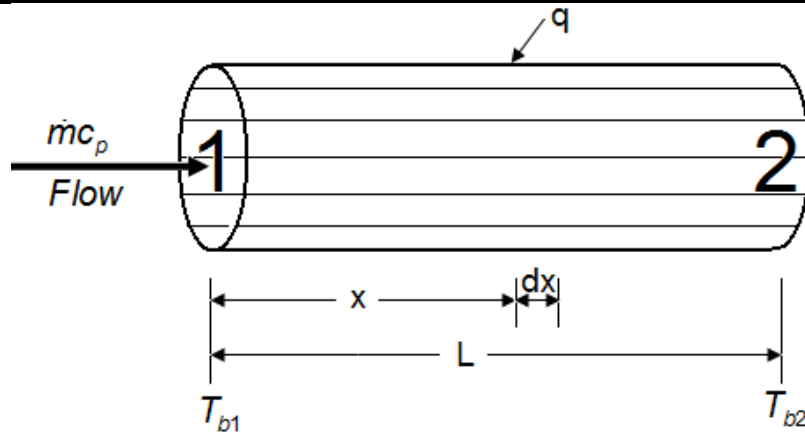

$$Q = \dot{m}c_p (T_{b2} - T_{b1})$$

$$dQ = \dot{m}c_p dT_b = h \{2\pi r dr (T_w - T_b)\}$$

- The bulk temperature represents energy average or 'mixing cup' conditions.
- The total energy 'exchange' in a tube flow can be expressed in terms of a bulk temperature difference.

IES-42. Ans. (b)

IES-43. Ans. (d)  $Gr_x = \frac{\beta g \Delta T x^3}{\nu^2}$



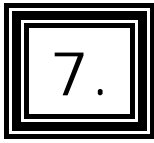

## Boiling and Condensation

Theory at a Glance (For IES, GATE, PSU)

### Boiling Heat Transfer

#### Boiling: General considerations

- Boiling is associated with transformation of liquid to vapor at a Solid/liquid interface due to convection heat transfer from the Solid.
- Agitation of fluid by vapor bubbles provides for large Convection coefficients and hence large heat fluxes at low-to-moderate Surface-to-fluid temperature differences.
- Special form of Newton's law of cooling:

$$q_1' = h(T_1 - T_m) = h\Delta T$$

Where  $T_m$  is the saturation temperature of the liquid, and  $\Delta T_e = T_1 - T_m$  is the excess temperature.

**Boiling** is a liquid-to-vapour phase change.

**Evaporation:** occurs at the liquid – vapour interface when  $P_v < P_{sat}$  at a given T (No bubble formation).

**Note:** A liquid-to-vapour phase changes is called evaporation if it occurs at a liquid – vapour interface and boiling if it occurs at a solid – liquid interface.

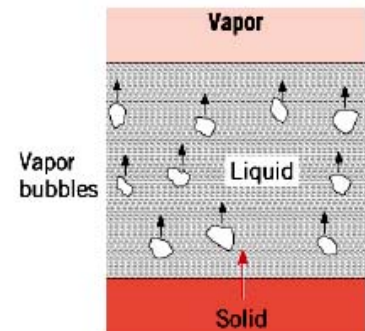

### Classification

- **Pool Boiling:** Liquid motion is due to natural convection and bubble-induced mixing.
- **Forced Convection Boiling:** Fluid motion is induced by external means, as well as by bubble-induced mixing.
- **Saturated Boiling:** Liquid temperature is slightly larger than saturation temperature.
- **Sub cooled Boiling:** Liquid temperature is less than saturation temperature.

### Boiling Regimes (The boiling curve)

The boiling curve reveals range of conditions associated with saturated pool boiling on a  $q_s''$  Vs  $\Delta T_e$  plot.

Water at Atmospheric Pressure

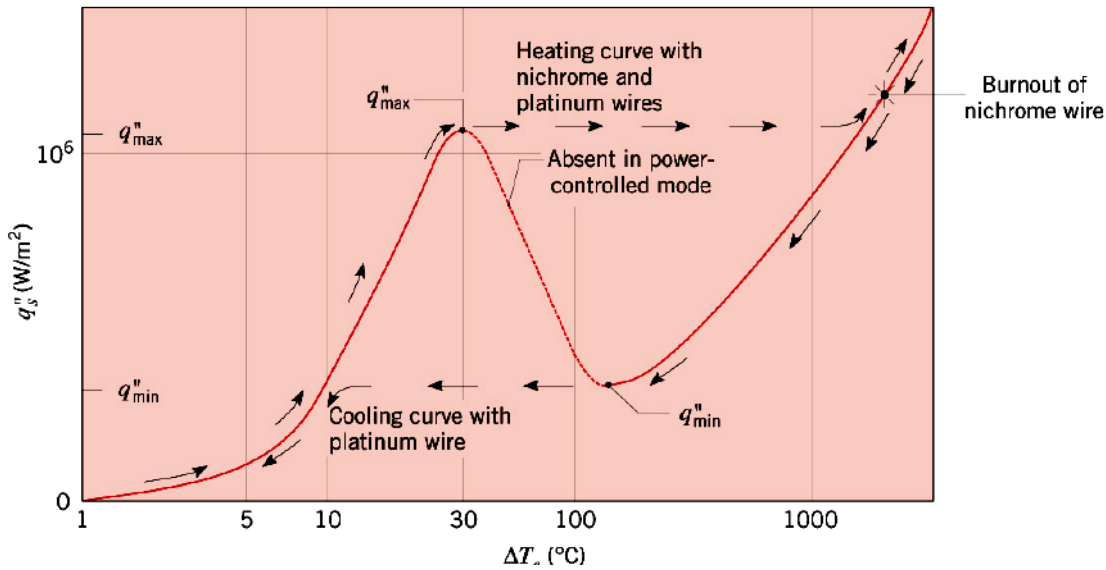

Water at Atmospheric Pressure

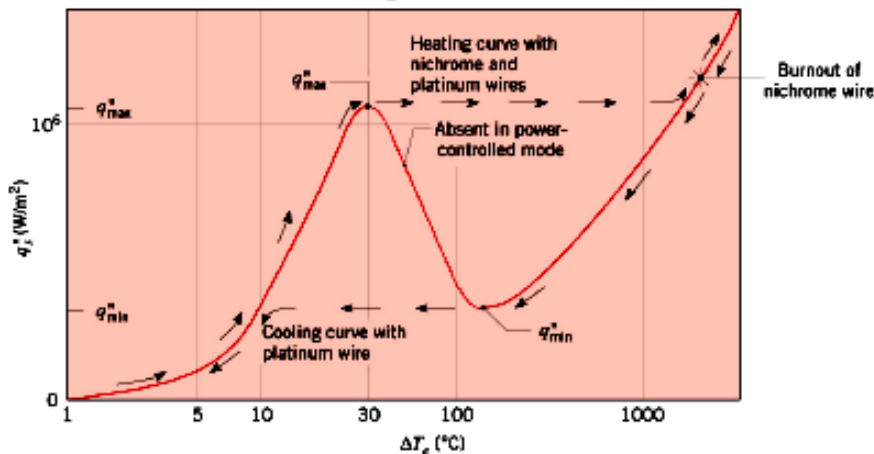

**Free Convection Boiling ( $\Delta T_e < 5^\circ\text{C}$ )**

- Little vapor formation.
- Liquid motion is due principally to single-phase natural Convection.

**Onset of Nucleate Boiling – ONB ( $\Delta T_e \approx 5^\circ\text{C}$ )**

**Nucleate boiling ( $5^\circ\text{C} < \Delta T_e < 30^\circ\text{C}$ )**

- **Isolated Vapor Bubbles ( $5^\circ\text{C} < \Delta T_e < 10^\circ\text{C}$ )** Liquid motion is strongly influenced by nucleation of bubbles at the surface.  $h$  and  $q''$  rise sharply with increasing  $\Delta T_e$ .

Heat transfer is principally due to contact of liquid with the surface (single-phase convection) and not to vaporization.

- **Jets and Columns ( $10^\circ\text{C} < \Delta T_e < 30^\circ\text{C}$ )** Increasing number of nucleation sites causes bubble interactions and coalescence into jets and slugs. Liquid/surface contact is impaired.  $q''$  Continues to increase with  $\Delta T_e$  while  $h$  begins to decrease.

**Critical Heat Flux – (CHF), ( $\Delta T_e \approx 30^\circ\text{C}$ )**

- Maximum attainable heat flux in nucleate boiling.

$q''_{\max} \approx 1\text{MW/m}^2$  For water at atmospheric pressure.

**Potential Burnout for Power-Controlled Heating**

- An increase in  $q''_s$  beyond  $q''_{\max}$  causes the surface to be blanketed by vapor and its temperature to spontaneously achieve a value that can exceed its melting point.
- If the surface survives the temperature shock, conditions are characterized by film boiling.

**Film Boiling**

- Heat transfer is by conduction and radiation across the vapor blanket.
- A reduction in  $q''_s$  follows the cooling curve continuously to the Leidenfrost point corresponding to the minimum heat flux  $q''_{\min}$  for film boiling.
- A reduction in  $q''_s$  below  $q''_{\min}$  causes an abrupt reduction in surface temperature to the nucleate boiling regime.

**Transition Boiling for Temperature-Controlled Heating**

- Characterized by continuous decay of  $q''_1$  (from  $q''_{\max}$  to  $q''_{\min}$ ) with increasing  $\Delta T_e$ .
- Surface conditions oscillate between nucleate and film boiling, but portion of surface experiencing film boiling increases with  $\Delta T_e$ .
- Also termed unstable or partial film boiling.

**Pool boiling correlations**

**Nucleate Boiling**

- Rohsenow Correlation, clean surfaces only,  $\pm 100\%$  errors

$$q''_s = \mu_l h_{fg} \left[ \frac{g(\rho_l - \rho_v)}{\sigma} \right]^{1/2} \left( \frac{c_{\rho,l} \Delta T_e}{C_{s,f} h_{fg} Pr_l^n} \right)^3$$

$C_{s,f}, n \rightarrow$  Surface/Fluid combination

**Critical heat flux**

$$q''_{\max} = 0.149 h_{fg} \rho_v \left[ \frac{\sigma g(\rho_l - \rho_v)}{\rho_v^2} \right]^{1/4}$$

**Film Boiling**

$$\overline{Nu}_D = \frac{\bar{h}_{conv} D}{k_v} = C \left[ \frac{g(\rho_l - \rho_v) h'_{fg} D^3}{v_v k_v (T_s - T_{sat})} \right]^{1/4}$$

Geometry	C
Cylinder (Horizontal)	0.62
Sphere	0.62

## Condensation Heat Transfer

### Condensation: General considerations

- Condensation occurs when the temperature of a vapour is reduced below its saturation temperature.
- Condensation heat transfer

#### Film condensation

##### Drop wise condensation

- Heat transfer rates in drop wise condensation *may be as much as 10 times higher* than in film condensation

### Condensation heat transfer

Film condensation

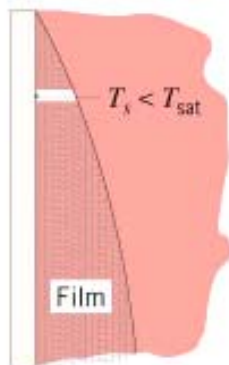

Drop wise condensation

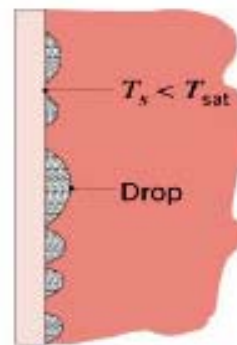

### Laminar Film condensation on a vertical wall

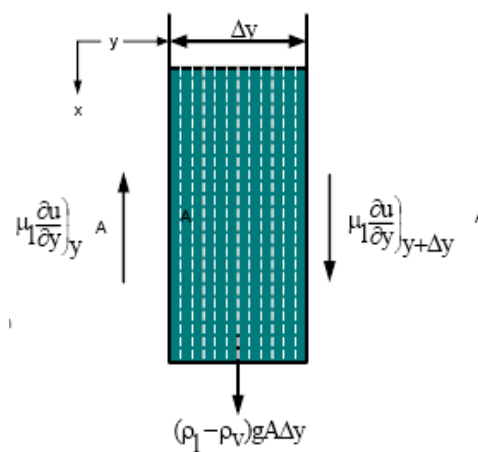
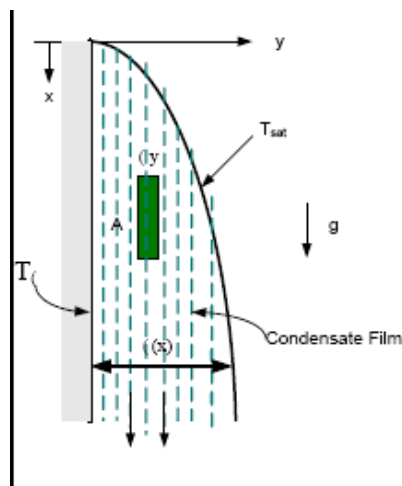

$$\delta(x) = \left[ \frac{4xk_l(T_{sat} - T_w)v_l}{h_{fg}g(\rho_l - \rho_v)} \right]^{1/4}$$

$$h(x) = \left[ \frac{h_{fg}g(\rho_l - \rho_v)k_l^3}{4x(T_{sat} - T_w)v_l} \right]^{1/4}$$

$$\text{Average coefficient} \quad \bar{h}_L = 0.943 \left[ \frac{h_{fg} g (\rho_l - \rho_v) k_l^3}{L (T_{sat} - T_w) \nu_l} \right]^{1/4}$$

Where,  $L$  is the plate length.

$$\text{Total heat transfer:} \quad q = \bar{h}_L A (T_{sat} - T_w)$$

$$\text{Condensation rate:} \quad \dot{m} = \frac{q}{h_{fg}} = \frac{\bar{h}_L A (T_{sat} - T_w)}{h_{fg}}$$

### Drop wise condensation can be achieved by:

- Adding a promoting chemical into the vapour (**Wax, fatty acid**)
- Treating the surface with a promoter chemical.
- **Coating** the surface with a polymer (Teflon) or Nobel metal (Gold, Silver, and Platinum).

**Question:** Discuss the different types of processes for condensation of vapors on a solid surface.

**Answer:** Whenever a saturated vapor comes in contact with a surface at a lower temperature condensation occurs.

- There are two modes of condensation.

**Film wise** in which the *condensation wets the surface forming a continuous film which covers the entire surface.*

**Drop wise** in which the *vapor condenses into small droplets of various sizes which fall down the surface in a random fashion.*

**Film wise condensation** generally occurs on *clean uncontaminated surfaces*. In this type of condensation the film covering the entire surface grows in thickness as it moves down the surface by gravity. There exists a thermal gradient in the film and so it acts as a resistance to heat transfer.

**In drop wise condensation** a large portion of the area of the plate is *directly exposed to the vapour, making heat transfer rates much higher (5 to 10 times) than those in film wise condensation.*

- Although drop wise condensation would be preferred to film wise condensation yet it is.

**Extremely difficult to achieve or maintain.** This is because most surfaces become *"wetted"* after being exposed to condensing vapours over a period of

time. Drop wise condensation *can be obtained under controlled conditions with the help of certain additives to the condensate and various surface coatings, but its commercial viability has not yet been proved. For this reason the condensing equipments in use are designed on the basis of film wise condensation.*

## OBJECTIVE QUESTIONS (GATE, IES, IAS)

## Previous 20-Years IES Questions

- IES-1.** Consider the following phenomena: [IES-1997]  
 1. Boiling 2. Free convection in air  
 3. Forced convection 4. Conduction in air  
 Their correct sequence in increasing order of heat transfer coefficient is:  
 (a) 4, 2, 3, 1 (b) 4, 1, 3, 2 (c) 4, 3, 2, 1 (d) 3, 4, 1, 2
- IES-2.** Consider the following statements regarding condensation heat transfer: [IES-1996]  
 1. For a single tube, horizontal position is preferred over vertical position for better heat transfer.  
 2. Heat transfer coefficient decreases if the vapour stream moves at high velocity.  
 3. Condensation of steam on an oily surface is dropwise.  
 4. Condensation of pure benzene vapour is always dropwise.  
 Of these statements  
 (a) 1 and 2 are correct (b) 2 and 4 are correct  
 (c) 1 and 3 are correct (d) 3 and 4 are correct.
- IES-3.** When all the conditions are identical, in the case of flow through pipes with heat transfer, the velocity profiles will be identical for: [IES-1997]  
 (a) Liquid heating and liquid cooling (b) Gas heating and gas cooling  
 (c) Liquid heating and gas cooling (d) Heating and cooling of any fluid
- IES-4.** Drop wise condensation usually occurs on [IES-1992]  
 (a) Glazed surface (b) Smooth surface (c) Oily surface (d) Coated surface

**Factors Affecting Nucleate Boiling**

- IES-5.** Consider the following statements regarding nucleate boiling:  
 1. The temperature of the surface is greater than the saturation temperature of the liquid. [IES-1995]  
 2. Bubbles are created by the expansion of entrapped gas or vapour at small cavities in the surface.  
 3. The temperature is greater than that of film boiling.  
 4. The heat transfer from the surface to the liquid is greater than that in film boiling.  
 Of these correct statements are:  
 (a) 1, 2 and 4 (b) 1 and 3 (c) 1, 2 and 3 (d) 2, 3 and 4  
 From the above curve it is clear that the temperature in nucleate boiling is less than that of film boiling. Statement 3 is wrong. Statement "4" The heat transfer from the surface to the liquid is greater than that in film boiling is correct.
- IES-6.** The burnout heat flux in the nucleate boiling regime is a function of which of the following properties? [IES-1993]  
 1. Heat of evaporation 2. Temperature difference

3. Density of vapour  
5. Vapour-liquid surface tension
4. Density of liquid

Select the correct answer using the codes given below:

Codes: (a) 1, 2, 4 and 5 (b) 1, 2, 3 and 5 (c) 1, 3, 4 and 5 (d) 2, 3 and 4

## Nucleate Pool Boiling

IES-7. The given figure shows a pool-boiling curve. Consider the following statements in this regard: [IES-1993]

1. Onset of nucleation causes a marked change in slope.
2. At the point B, heat transfer coefficient is the maximum.
3. In an electrically heated wire submerged in the liquid, film heating is difficult to achieve.
4. Beyond the point C, radiation becomes significant

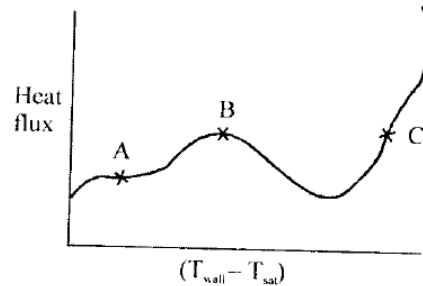

Of these statements:

- (a) 1, 2 and 4 are correct  
(b) 1, 3 and 4 are correct  
(c) 2, 3 and 4 are correct  
(d) 1, 2 and 3 are correct

IES-8. Assertion (A): If the heat fluxes in pool boiling over a horizontal surface is increased above the critical heat flux, the temperature difference between the surface and liquid decreases sharply. [IES-2003]

Reason (R): With increasing heat flux beyond the value corresponding to the critical heat flux, a stage is reached when the rate of formation of bubbles is so high that they start to coalesce and blanket the surface with a vapour film.

- (a) Both A and R are individually true and R is the correct explanation of A  
(b) Both A and R are individually true but R is **not** the correct explanation of A  
(c) A is true but R is false  
(d) A is false but R is true

## Film Pool Boiling

IES-9. In spite of large heat transfer coefficients in boiling liquids, fins are used advantageously when the entire surface is exposed to: [IES-1994]

- (a) Nucleate boiling (b) Film boiling  
(c) Transition boiling (d) All modes of boiling

IES-10. When a liquid flows through a tube with sub-cooled or saturated boiling, what is the process known? [IES-2009]

- (a) Pool boiling (b) Bulk boiling  
(c) Convection boiling (d) Forced convection boiling

## Condensation Heat Transfer

IES-11. For film-wise condensation on a vertical plane, the film thickness  $\delta$  and heat transfer coefficient  $h$  vary with distance  $x$  from the leading edge as [IES-2010]



- (a)  $\delta$  decreases,  $h$  increases  
 (b) Both  $\delta$  and  $h$  increase  
 (c)  $\delta$  increases,  $h$  decreases  
 (d) Both  $\delta$  and  $h$  decrease

**IES-12. Saturated steam is allowed to condense over a vertical flat surface and the condensate film flows down the surface. The local heat transfer coefficient for condensation** [IES-1999]

- (a) Remains constant at all locations of the surface  
 (b) Decreases with increasing distance from the top of the surface  
 (c) Increases with increasing thickness of condensate film  
 (d) Increases with decreasing temperature differential between the surface and vapour

**IES-13. Consider the following statements:** [IES-1998]

1. If a condensing liquid does not wet a surface drop wise, then condensation will take place on it.
2. Drop wise condensation gives a higher heat transfer rate than film-wise condensation.
3. Reynolds number of condensing liquid is based on its mass flow rate.
4. Suitable coating or vapour additive is used to promote film-wise condensation.

**Of these statements:**

- (a) 1 and 2 are correct  
 (b) 2, 3 and 4 are correct  
 (c) 4 alone is correct  
 (d) 1, 2 and 3 are correct

**IES-14. Assertion (A): Even though dropwise condensation is more efficient, surface condensers are designed on the assumption of film wise condensation as a matter of practice.** [IES-1995]

**Reason (R): Dropwise condensation can be maintained with the use of promoters like oleic acid.**

- (a) Both A and R are individually true and R is the correct explanation of A  
 (b) Both A and R are individually true but R is **not** the correct explanation of A  
 (c) A is true but R is false  
 (d) A is false but R is true

**IES-15. Assertion (A): Drop-wise condensation is associated with higher heat transfer rate as compared to the heat transfer rate in film condensation.** [IES-2009]

**Reason (R): In drop condensation there is free surface through which direct heat transfer takes place.**

- (a) Both A and R are individually true and R is the correct explanation of A  
 (b) Both A and R individually true but R is not the correct explanation of A  
 (c) A is true but R is false  
 (d) A is false but R is true

**IES-16. Assertion (A): The rate of condensation over a rusty surface is less than that over a polished surface.** [IES-1993]

**Reason (R): The polished surface promotes drop wise condensation which does not wet the surface.**

- (a) Both A and R are individually true and R is the correct explanation of A  
 (b) Both A and R are individually true but R is **not** the correct explanation of A

- (c) A is true but R is false
- (d) A is false but R is true

**IES-17. Consider the following statements: [IES-1997]**

**The effect of fouling in a water-cooled steam condenser is that it**

- 1. Reduces the heat transfer coefficient of water.**
- 2. Reduces the overall heat transfer coefficient.**
- 3. Reduces the area available for heat transfer.**
- 4. Increases the pressure drop of water**

**Of these statements:**

- (a) 1, 2 and 4 are correct
- (b) 2, 3 and 4 are correct
- (c) 2 and 4 are correct
- (d) 1 and 3 are correct

Answers with Explanation (Objective)

Previous 20-Years IES Answers

IES-1. Ans. (a) Air being insulator, heat transfer by conduction is least. Next is free convection, followed by forced convection. Boiling has maximum heat transfer

IES-2. Ans. (c)

IES-3. Ans. (a) The velocity profile for flow through pipes with heat transfer is identical for liquid heating and liquid cooling.

IES-4. Ans. (c)

IES-5. Ans. (a)

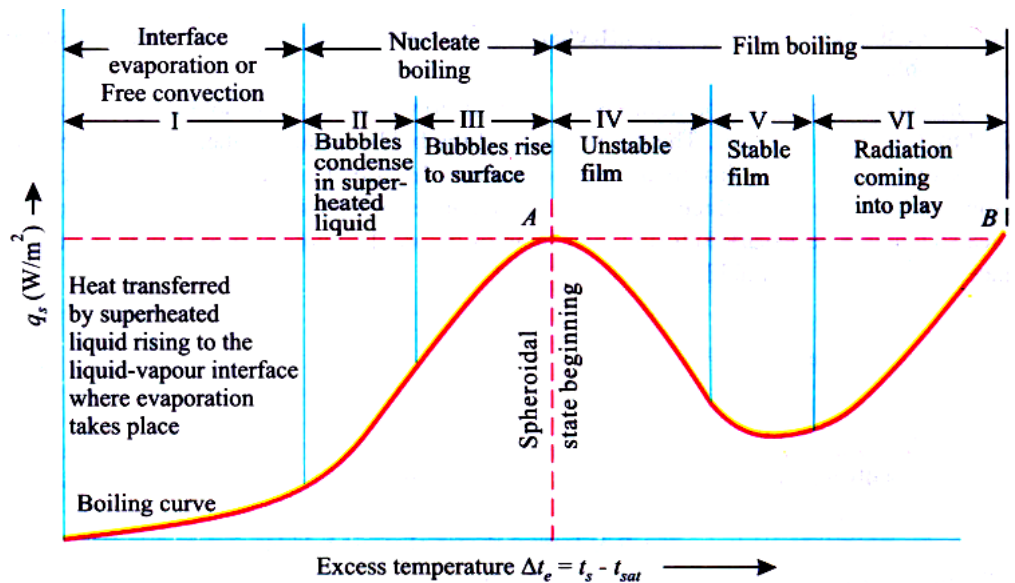

IES-6. Ans. (c)  $q_{sc} = 0.18(\rho_v)^{1/2} h_{fg} [g\sigma(\rho_l - \rho_v)]^{1/4}$

IES-7. Ans. (c)

IES-8. Ans. (d) The temperature difference between the surface and liquid increases sharply.

IES-9. Ans. (b)

IES-10. Ans. (d) **Pool Boiling:** Liquid motion is due to natural convection and bubble-induced mixing.

**Forced Convection Boiling:** Fluid motion is induced by external means, as well as by bubble-induced mixing.

**Saturated Boiling:** Liquid temperature is slightly larger than saturation temperature.

**Sub-cooled Boiling:** Liquid temperature is less than saturation temperature.

**Bulk Boiling:** As system temperature increase or system pressure drops, the bulk fluid can reach saturation conditions. At this point, the bubbles entering the coolant channel will not collapse. The bubbles will tend to join together and form bigger steam bubbles. This phenomenon is referred to as bulk boiling bulk.

Boiling can provide adequate heat transfer provide that the system bubbles are carried away from the heat transfer surface and the surface continually wetted with liquids water. When this cannot occur film boiling results. So the answer must not be Bulk boiling.

$$\text{IES-11. Ans. (c)} \quad \delta(x) = \left[ \frac{4x K_l (T_{sat} - T_w) \nu_l}{h_{fg} g(\rho_l - \rho_v)} \right]^{\frac{1}{4}} \therefore \delta \propto x^{\frac{1}{4}}$$

$$h(x) = \left[ \frac{h_{fg} \times g(\rho_l - \rho_v) K_l^3}{4x (T_{sat} - T_w) \nu_l} \right]^{\frac{1}{4}} \therefore h(x) \propto \left( \frac{1}{x} \right)^{\frac{1}{4}}$$

**IES-12. Ans. (b)**  $h_x \propto x^{-1/4}$

**IES-13. Ans. (d)** 1. If a condensing liquid does not wet a surface drop wise, then drop-wise condensation will take place on it.

4. Suitable coating or vapour additive is used to promote drop-wise condensation.

**IES-14. Ans. (b)** A and R are true. R is not correct reason for A.

**IES-15. Ans. (a)**

**IES-16. Ans. (a)** Both A and R are true and R provides satisfactory explanation for A.

**IES-17. Ans. (b)** The pipe surface gets coated with deposited impurities and scale gets formed due the chemical reaction between pipe material and the fluids. This coating has very low thermal conductivity and hence results in high thermal resistance. Pressure will be affected.

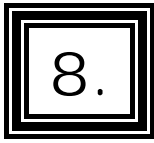

## 8. Heat Exchangers

### Theory at a Glance (For IES, GATE, PSU)

#### Rules to remember:

- (i) If two temperatures is known, **use NTU Method.**
- (ii) If three temperatures is known, **use simple heat balance method.**
- (iii) If four temperatures is known, **then you have to calculate**  $\frac{C_{\min}}{C_{\max}}$
- (iv)  $C_p$  &  $C_v$  must be in J/kg k not in kJ/Kgk.

#### What are heat exchangers for?

- ❖ Heat exchangers are practical devices used to transfer energy from one fluid to another.
- ❖ To get fluid streams to the right temperature for the next process– Reactions often require feeds at high temperature.
- ❖ To condense vapours.
- ❖ To evaporate liquids.
- ❖ To recover heat to use elsewhere.
- ❖ To reject low-grade heat.
- ❖ To drive a power cycle.

#### Types of Heat Exchangers

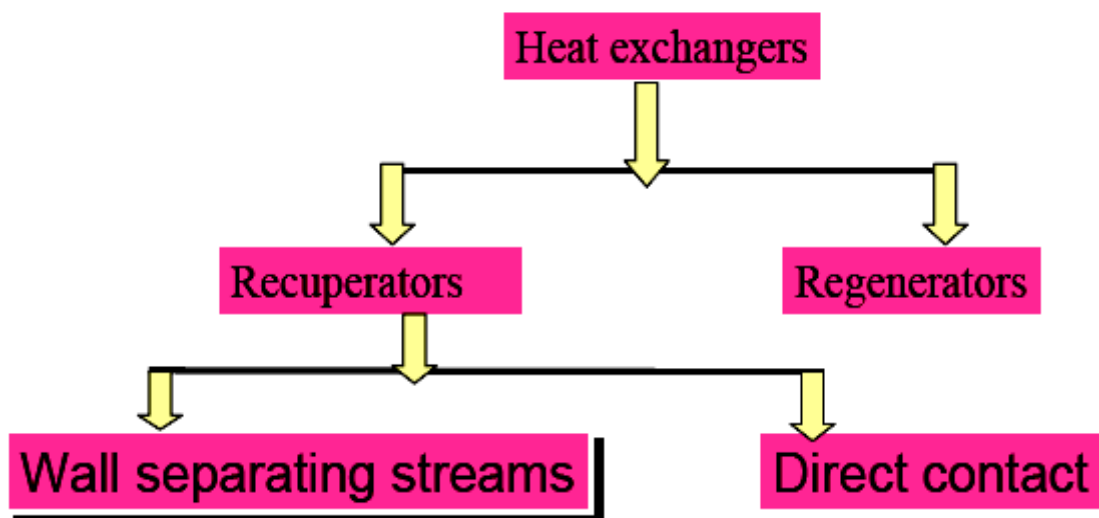

- ❖ Most heat exchangers have two streams, *hot* and *cold*, but Some have more than two

- ❖ **Recuperative:**  
Has separate flow paths for each fluid which flow simultaneously through the Exchanger transferring heat between the streams.
- ❖ **Regenerative:**  
Has a single flow path which the hot and cold fluids alternately pass through.

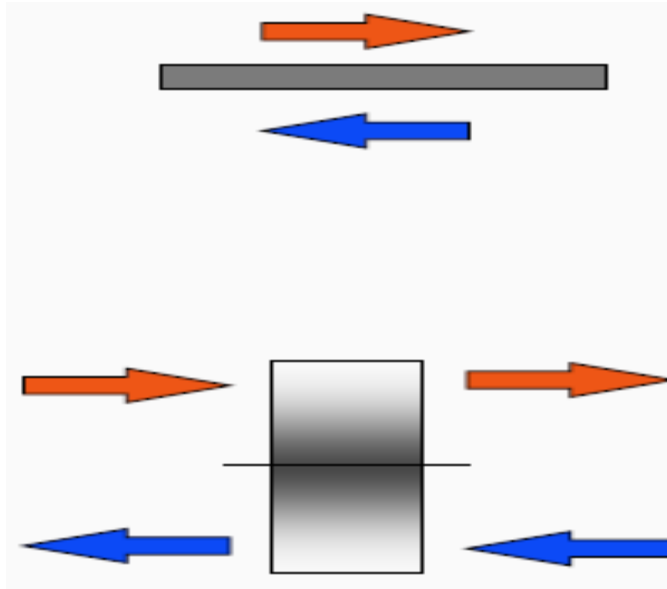

## Compactness

- ❖ Can be measured by the heat-transfer area per unit volume or by channel size.
- ❖ Conventional exchangers (shell and tube) have channel Size of 10 to 30 mm giving about  $100\text{m}^2/\text{m}^3$ .
- ❖ Plate-type exchangers have typically 5mm channel size with more than  $200\text{m}^2/\text{m}^3$
- ❖ More compact types available.

## Double Pipe Heat Exchanger

- ❖ Simplest type has one tube inside another - inner tube may have longitudinal fins on the outside

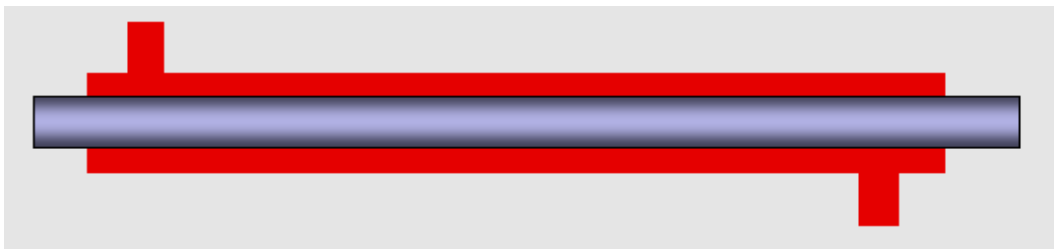

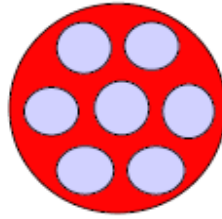

- ❖ However, most have a number of tubes in the outer tube - can have many tubes thus becoming a shell-and-tube.

## Shell and Tube Heat Exchanger

- ❖ Typical shell and tube exchanger as used in the process industry

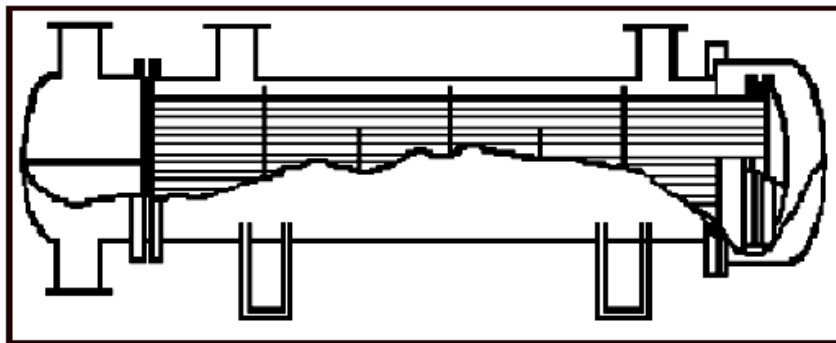

## Shell-Side Flow

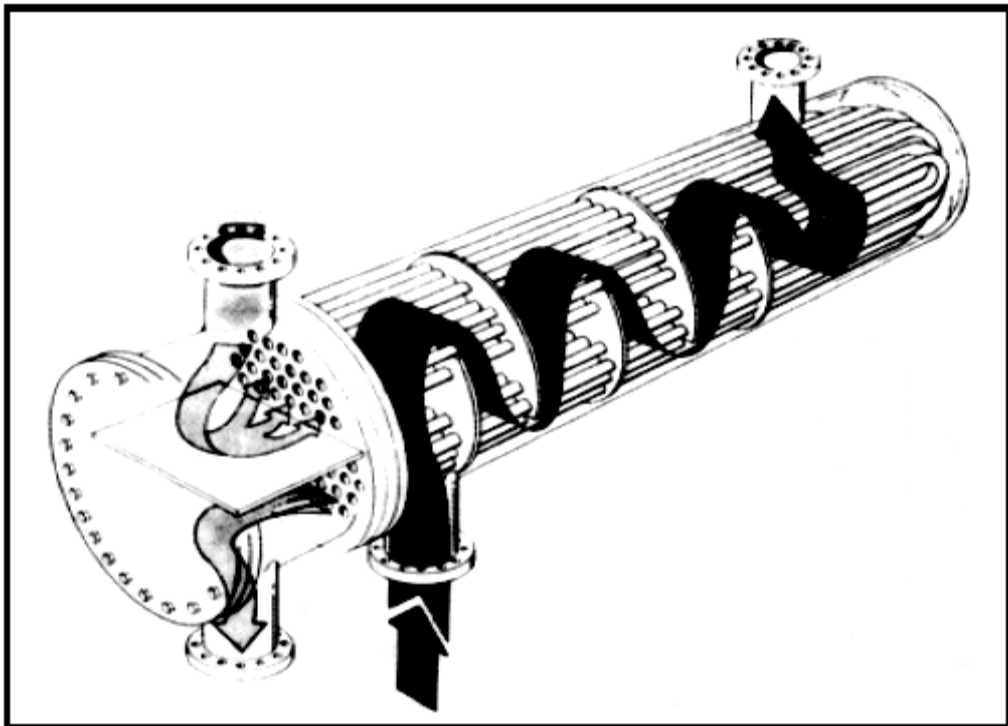

## Plate-Fin Exchanger

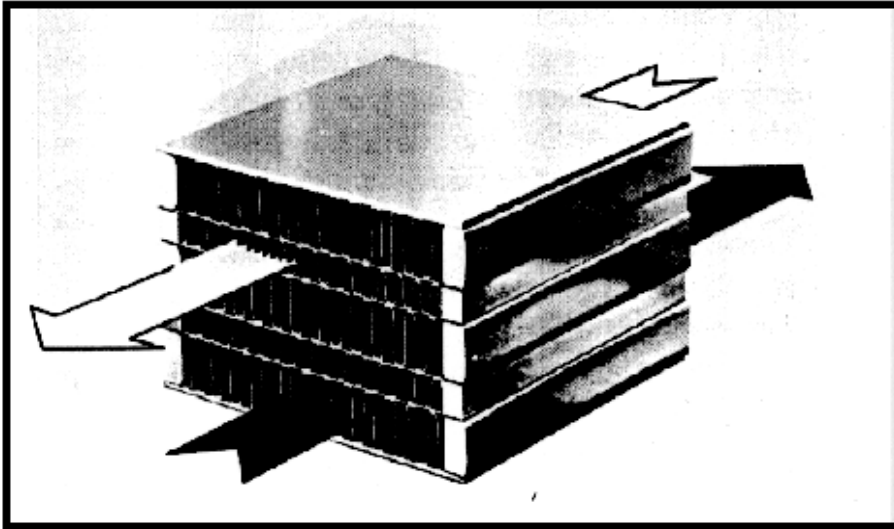

- ❖ Made up of flat plates (parting sheets) and corrugated sheets which form fins
- ❖ Brazed by heating in vacuum furnace.

## Configurations

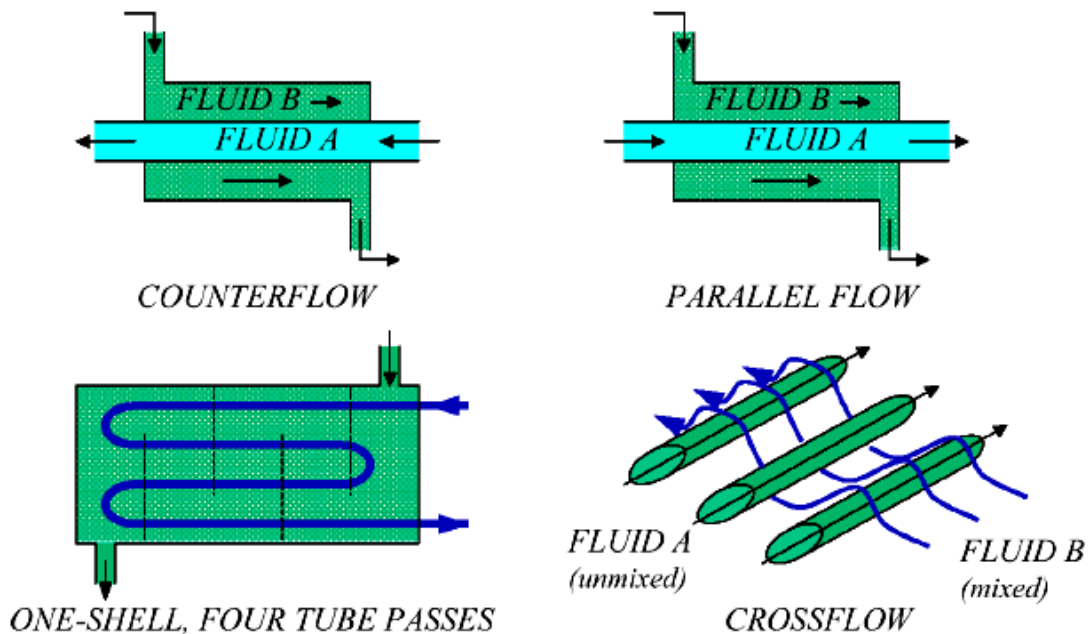

## Fouling:

- **Scaling:** Mainly  $\text{CaCO}_3$  salt deposition.
- **Corrosion fouling:** Adherent oxide coatings.
- **Chemical reaction fouling:** Involves chemical reactions in the process stream which results in deposition of material on the exchanger tubes. When food products are involved this may be termed scorching but a wide range of organic materials are subject to similar problems.
- **Freezing fouling:** In refineries paraffin frequently solidifies from petroleum products.



- **Biological fouling:** It is common where untreated water is used as a coolant stream. Problem range or other microbes to barnacles.
- **Particulate fouling:** Brownian sized particles

### Basic Flow Arrangement in Tube in Tube Flow

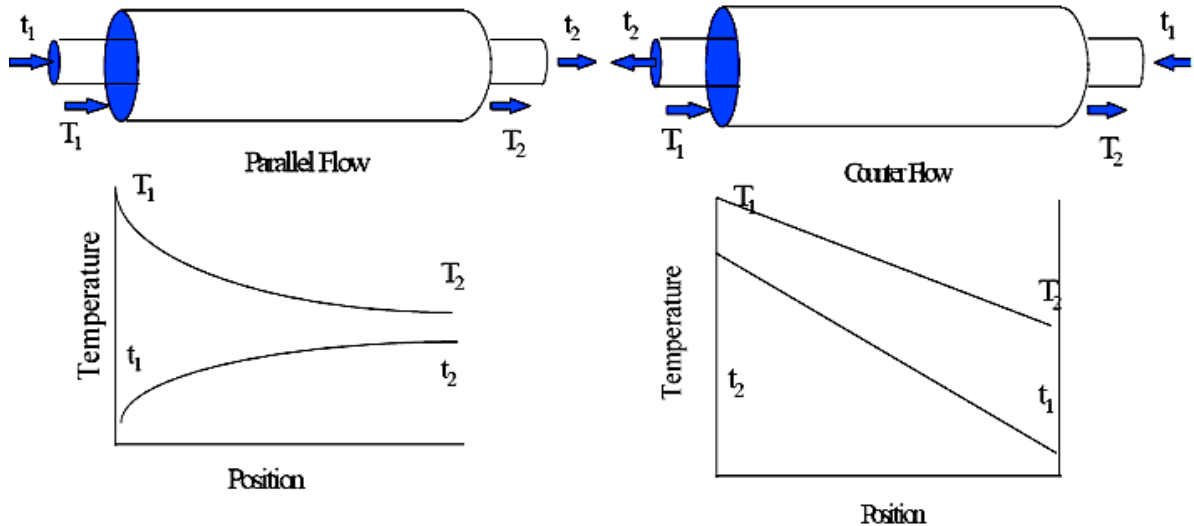

### Flow Arrangement Condenser and Evaporator

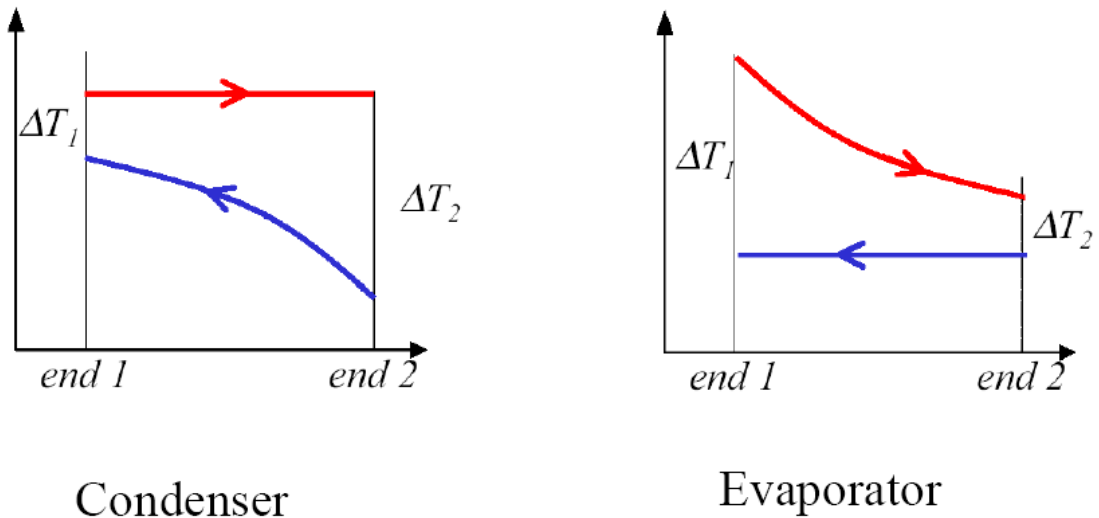

**Temperature ratio, (P):** It is defined as the ratio of the rise in temperature of the cold fluid to the difference in the inlet temperatures of the two fluids. Thus:

$$\text{Temperature ratio, (P)} = \frac{t_{c_2} - t_{c_1}}{t_{h_1} - t_{c_1}}$$

Where subscripts h and c denote the hot and cold fluids respectively, and the subscripts 1 and 2 refer to the inlet and outlet conditions respectively.

The temperature ratio, (P) indicates cooling or heating effectiveness and it can vary from zero for a constant temperature of one of the fluids to unity for the case when inlet temperature of the hot fluid equals the outlet temperature of the cold fluid.

**Capacity ratio, (R):** The ratio of the products of the mass flow rate times the heat capacity of the fluids is termed as capacity ratio R. Thus

$$R = \frac{\dot{m}_c \cdot c_{pc}}{\dot{m}_h \cdot c_{ph}}$$

Since,  $\dot{m}_c \cdot c_{pc} \cdot (t_{c2} - t_{c1}) = \dot{m}_h \cdot c_{ph} \cdot (t_{h1} - t_{h2})$

or,

$$\begin{aligned} \text{Capacity ratio, (R)} &= \frac{\dot{m}_c c_{pc}}{\dot{m}_h c_{ph}} = \frac{t_{h1} - t_{h2}}{t_{c2} - t_{c1}} \\ &= \frac{\text{Temperature dropping hot fluid}}{\text{Temperature dropping cold fluid}} \end{aligned}$$

$$\begin{aligned} \text{Effectiveness, } (\epsilon) &= \frac{\text{actual heat transfer}}{\text{maximum possible heat transfer}} = \frac{Q}{Q_{\max}} \\ &= \frac{C_h (t_{h1} - t_{h2})}{C_{\min} (t_{h1} - t_{c1})} = \frac{C_c (t_{c2} - t_{c1})}{C_{\min}} \end{aligned}$$

$$\text{or } Q = \epsilon C_{\min} (t_{h1} - t_{c1})$$

## Logarithmic Mean Temperature Difference (LMTD)

### Assumptions:

1. The heat exchanger is insulated from its surroundings, in which case the only heat exchanger is between the hot and cold fluids.
2. Axial conduction along the tubes is negligible
3. Potential and kinetic energy changes are negligible.
4. The fluid specific heats are constant.
5. The overall heat transfer co-efficient is constant.

### LMTD for parallel flow:

#### Applying energy balance

$$dq = -\dot{m}_h C_{ph} dT_h = -C_h dT_h$$

$$dq = \dot{m}_c C_{pc} dT_c = C_c dT_c$$

$$dq = U \times dT \times dA$$

$$\theta = T_h - T_c$$

$$\text{or } d(\theta) = dT_h - dT_c$$

$$= -dq \left( \frac{1}{C_h} + \frac{1}{C_c} \right)$$

Substituting equation

$$d(\theta) = -UdTdA \left( \frac{1}{C_h} + \frac{1}{C_c} \right)$$

$$\int_1^2 \frac{d(\theta)}{\theta} = -U \left( \frac{1}{C_h} + \frac{1}{C_c} \right) \int dA$$

$$\text{or } \ln \left( \frac{\theta_2}{\theta_1} \right) = -UA \left( \frac{1}{C_h} + \frac{1}{C_c} \right)$$

$$\text{Now } q = C_h (T_{hi} - T_{ho}) = C_c (T_{co} - T_{ci})$$

$$\text{or } \frac{1}{C_h} = \frac{T_{hi} - T_{ho}}{q}$$

$$\text{and } \frac{1}{C_c} = \frac{T_{co} - T_{ci}}{q}$$

$$\text{or } \ln \left( \frac{\theta_2}{\theta_1} \right) = -\frac{UA}{q} [(T_{hi} - T_{ci}) - (T_{ho} - T_{co})]$$

$$= -\frac{UA}{q} [\theta_1 - \theta_2]$$

$$\text{or } q = UA \frac{\theta_2 - \theta_1}{\ln \left( \frac{\theta_2}{\theta_1} \right)}$$

$$\text{or } q = UA (LMTD)$$

$$\text{now } LMTD = \frac{\theta_2 - \theta_1}{\ln \left( \frac{\theta_2}{\theta_1} \right)}$$

$$LMTD = \frac{(\theta_1) - (\theta_2)}{\ln \left( \frac{\theta_1}{\theta_2} \right)}$$

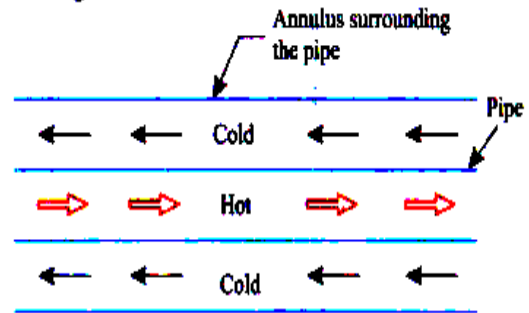

(a) Flow arrangement

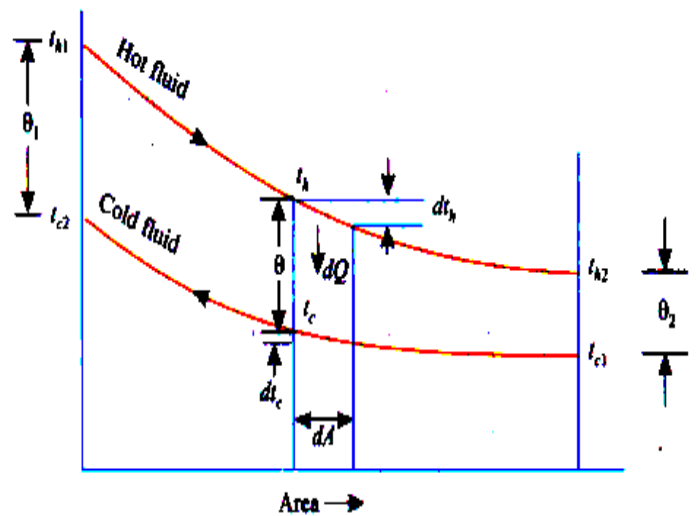

LMTD for parallel flow

$C_h$  and  $C_c$  are the hot and cold fluid heat capacity rates, respectively

**LMTD for counter flow:**

$$dt_h = -\frac{dQ}{C_h}$$

$$dt_c = -\frac{dQ}{C_c}$$

or  $d\theta = dt_h - dt_c$

$$= -dQ \left[ \frac{1}{C_h} - \frac{1}{C_c} \right]$$

$$\text{or } \int_1^2 \frac{d\theta}{\theta} = -U \int_{A=0}^{A=A} dA \left[ \frac{1}{C_h} - \frac{1}{C_c} \right]$$

$$\ln \left( \frac{\theta_2}{\theta_1} \right) = -UA \left[ \frac{1}{C_h} - \frac{1}{C_c} \right],$$

$$\frac{1}{C_h} = \frac{t_{h1} - t_{hc}}{Q}$$

$$\frac{1}{C_c} = \frac{t_{c2} - t_{c1}}{Q}, \quad Q = UA\theta_m$$

$$LMTD = \frac{\theta_2 - \theta_1}{\ln \left( \frac{\theta_2}{\theta_1} \right)}$$

if  $\theta_1 = \theta_2$  then  $LMTD = \lim_{\theta_2 \rightarrow \theta_1} \frac{\theta_2 - \theta_1}{\ln \left( \frac{\theta_2}{\theta_1} \right)} = \theta = \theta_1 = \theta_2$

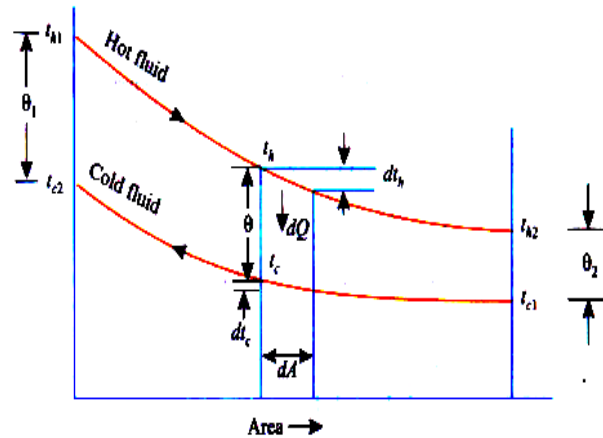
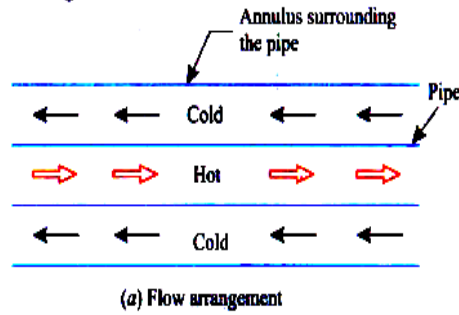

$$dQ = U dA (t_h - t_c) = U dA \theta$$

- For evaporators and condensers, for the given conditions, the logarithmic mean temperature difference (LMTD) for parallel flow is equal to that for counter flow.

### Overall Heat Transfer Coefficient, (U)

Inside surface resistance,  $R_{si} = \frac{1}{A_i h_{si}}$

Outside surface resistance,  $R_{so} = \frac{1}{A_o h_{so}}$

$$Q = \frac{t_i - t_o}{\frac{1}{A_i h_i} + \frac{1}{A_i h_{si}} + \frac{1}{2\pi k L} \ln(r_o/r_i) + \frac{1}{A_o h_{so}} + \frac{1}{A_o h_o}}$$

$$= U_i A_i (t_i - t_o) = U_o A_o (t_i - t_o)$$

$$U_i = \frac{1}{\frac{1}{h_i} + \frac{1}{h_{si}} + \frac{r_i}{k} \ln(r_o/r_i) + \left(\frac{r_i}{r_o}\right) \frac{1}{h_{so}} + \frac{r_i}{r_o} \cdot \frac{1}{h_o}}$$

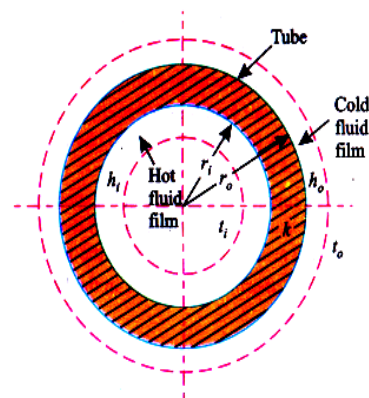

$$U_i A_i = U_o A_o; \quad A_i = 2\pi r_i L \quad \text{and} \quad A_o = 2\pi r_o L$$

where  $\frac{1}{h_{si}} \Rightarrow R_{fi}$ ,  $\frac{1}{h_{so}} \Rightarrow R_{fo}$  then,  $U_o = \frac{1}{\frac{r_o}{r_i} \frac{1}{h_i} + \frac{r_o}{r_i} \frac{1}{h_{si}} + \frac{r_o}{k} \ln(r_o/r_i) + \frac{1}{h_{so}} + \frac{1}{h_o}}$

## Heat Exchanger Effectiveness and Number of Transfer Units (NTU)

How will existing Heat Exchanger perform for given inlet conditions?

Define effectiveness:

$$\varepsilon = \frac{\dot{Q}_{actual}}{\dot{Q}_{max}}$$

Where  $\dot{Q}_{max}$  is for an infinitely long heat exchanger

One fluid  $\Delta T \rightarrow \Delta T_{max} = T_{h,in} - T_{c,in}$

AND SINCE

$$\begin{aligned}\dot{Q} &= (\dot{m}c_A)\Delta T_A = (\dot{m}c_B)\Delta T_B \\ &= C_A\Delta T_A = C_B\Delta T_B\end{aligned}$$

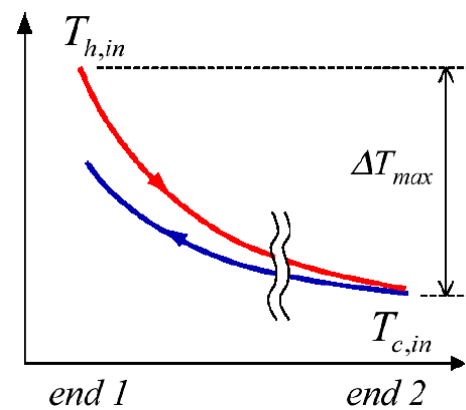
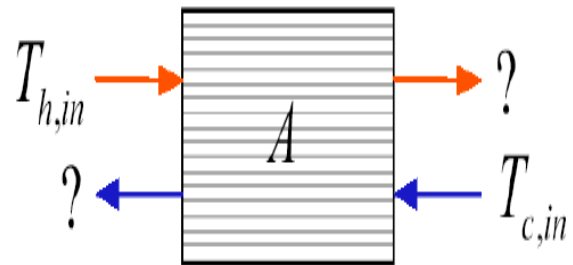

Then only the fluid with lesser of  $C_A$ ,  $C_B$  heat capacity rate can have  $T_{max}$

$$\text{i.e. } \dot{Q}_{max} = C_{min}\Delta T_{max} \quad \text{and} \quad \varepsilon = \frac{\dot{Q}}{C_{min}(T_{h,in} - T_{c,in})}$$

$$\text{or, } \dot{Q} = \varepsilon C_{min}(T_{h,in} - T_{c,in})$$

Therefore

$$\begin{aligned}\text{Effectiveness, } \varepsilon &= \frac{\text{actual heat transfer}}{\text{maximum possible heat transfer}} = \frac{Q}{\dot{Q}_{max}} \\ &= \frac{C_h(t_{h1} - t_{h2})}{C_{min}(t_{h1} - t_{c1})} = \frac{C_c(t_{c2} - t_{c1})}{C_{min}}\end{aligned}$$

$$\text{or } Q = \varepsilon C_{min}(t_{h1} - t_{c1})$$

The 'NTU' (Number of Transfer Units) in a heat exchanger is given by,

$$NTU = \frac{UA}{C_{\min}}$$

Where:

- U = Overall heat transfer coefficient
- C = Heat capacity
- $\epsilon$  = Effectiveness
- A = Heat exchange area.

$$\therefore \epsilon = \epsilon \left( NTU, \frac{C_{\min}}{C_{\max}} \right)$$

### For parallel flow NTU method

$$d(t_h - t_c) = -dQ \left( \frac{1}{c_h} + \frac{1}{c_c} \right)$$

or 
$$\frac{d(t_h - t_c)}{(t_h - t_c)} = -UdA \left( \frac{1}{c_h} + \frac{1}{c_c} \right)$$

Hence, 
$$t_{h2} = t_{h1} - \frac{\epsilon c_{\min} (t_{h1} - t_{c1})}{c_h}$$

$$t_{c2} = t_{c1} + \frac{\epsilon c_{\min} (t_{h1} - t_{c1})}{C_c}$$

and get 
$$\epsilon = \frac{1 - e^{-NTU \left( 1 + \frac{C_{\min}}{C_{\max}} \right)}}{1 + \frac{C_{\min}}{C_{\max}}}$$

$$\epsilon = \frac{1 - e^{-NTU(1+R)}}{1 + R} \quad \text{(parallel flow)}$$

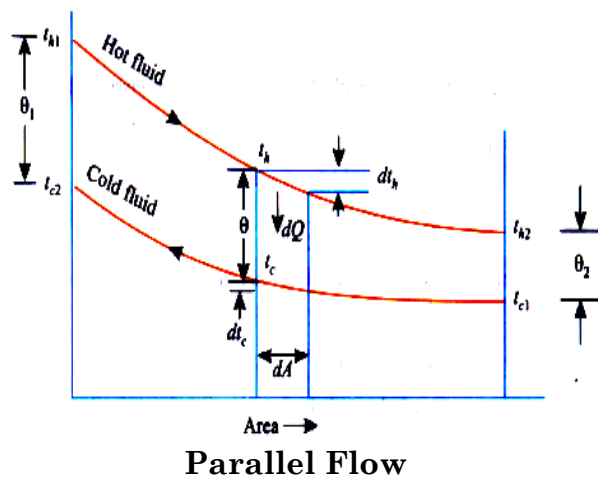
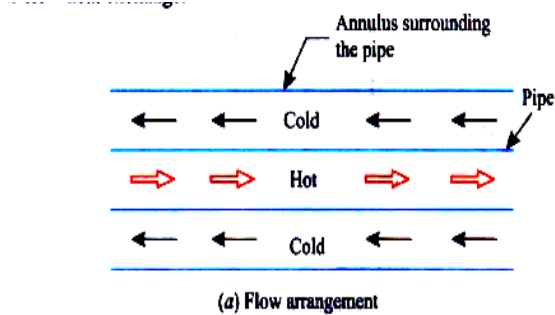

### For Counter flows NTU method

Similarly

$$\epsilon = \frac{1 - e^{-NTU(1-R)}}{1 - R e^{-NTU(1-R)}} \quad \text{(counter flow)}$$

**Case-I:** when  $R \approx 0$ , condenser and evaporator (boilers)

$$\epsilon = 1 - e^{-NTU} \quad \text{For parallel and counter flow.}$$

$$\epsilon = \frac{1 - e^{-NTU \left(1 + \frac{C_{\min}}{C_{\max}}\right)}}{1 + \frac{C_{\min}}{C_{\max}}} = 1 - e^{-NTU} \quad \text{For Parallel flow [As boiler and condenser } \frac{C_{\min}}{C_{\max}} \rightarrow 0]$$

$$= \frac{1 - e^{-NTU \left(1 + \frac{C_{\min}}{C_{\max}}\right)}}{1 + \frac{C_{\min}}{C_{\max}} e^{-NTU \left(1 + \frac{C_{\min}}{C_{\max}}\right)}} = 1 - e^{-NTU} \quad \text{For Counter flow}$$

Case-II:  $R = 1$

$$\epsilon = \frac{1 - e^{-2NTU}}{2} \quad \text{for gas turbine (parallel flow)}$$

$$= \frac{NTU}{1 + NTU} \quad \text{for gas turbine (counter flow)}$$

## Heat Pipe

Heat pipe is device used to obtain very high rates of heat flow. In practice, the thermal conductance of heat pipe may be several hundred (500) times then that best available metal conductor; hence they act as super conductor.

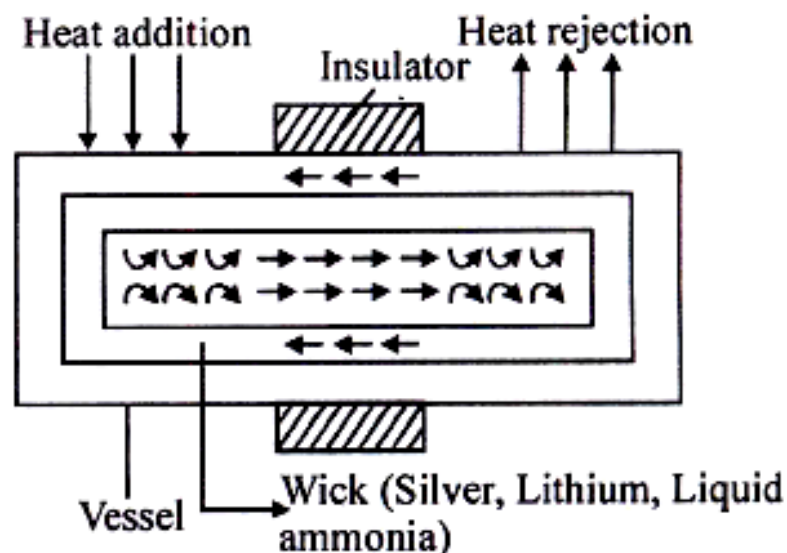

**HEAT EXCHANGER (Formula List)**

$$(i) \quad \text{LMTD} = \frac{\theta_1 - \theta_2}{\ln\left(\frac{\theta_1}{\theta_2}\right)}; \text{ if } \theta_1 = \theta_2, \text{ then LMTD} = \theta_1 = \theta_2$$

$$U_i = \frac{1}{\frac{1}{h_i} + \frac{1}{h_{si}} + \frac{r_i}{k} \ln(r_o/r_i) + \left(\frac{r_i}{r_o}\right) \frac{1}{h_{so}} + \frac{r_i}{r_o} \cdot \frac{1}{h_o}}$$

$$\text{where } \frac{1}{h_{si}} \Rightarrow R_{fi}, \frac{1}{h_{so}} \Rightarrow R_{fo}$$

$$U_o = \frac{1}{\frac{r_o}{r_i} \frac{1}{h_i} + \frac{r_o}{r_i} \frac{1}{h_{si}} + \frac{r_o}{k} \ln(r_o/r_i) + \frac{1}{h_{so}} + \frac{1}{h_o}}$$

$$(iii) \quad Q = UA(\text{LMTD})$$

$$(iv) \quad Q = \text{Heat transfer} = m_h C_{ph} (T_{h1} - T_{h2}) = m_c C_{pc} (T_{c2} - T_{c1})$$

$$(v) \quad mC_p = C$$

$$(vi) \quad \text{Effectiveness, } (\epsilon) = \frac{\text{Actual heat transfer}}{\text{maximum possible heat transfer}} = \frac{C_h (T_{h1} - T_{h2})}{C_{\min} (T_{h1} - T_{c1})} = \frac{C_c (T_{c2} - T_{c1})}{C_{\min} (T_{h1} - T_{c1})}$$

$$(vii) \quad \text{Number of transfer unit, (NTU)} = \frac{UA}{C_{\min}}; \text{ It is indicative of the size of the heat exchanger.}$$

$$(ix) \quad \epsilon = \frac{1 - e^{-NTU \left(1 + \frac{C_{\min}}{C_{\max}}\right)}}{1 + \frac{C_{\min}}{C_{\max}}} \quad \text{for parallel flow}$$

$$= \frac{1 - e^{-NTU \left(1 - \frac{C_{\min}}{C_{\max}}\right)}}{1 - \frac{C_{\min}}{C_{\max}} \cdot e^{-NTU \left(1 - \frac{C_{\min}}{C_{\max}}\right)}} \quad \text{for counter flow}$$

If NTU  $\uparrow$  then  $\epsilon \uparrow$

if  $\frac{C_{\min}}{C_{\max}} \uparrow$  then  $\epsilon \downarrow$

$$(x) \quad \epsilon = 1 - e^{-NTU} \text{ for Boiler and condenser parallel or counter flow as } C_{\min} / C_{\max} \rightarrow 0$$

$$\left. \begin{aligned} &= \frac{1}{2} (1 - e^{-2NTU}) \text{ parallel flow} \\ &= \frac{NTU}{1 + NTU} \text{ counter flow} \end{aligned} \right\} \text{ for gas turbine heat exchanger where } C_{\min} / C_{\max} = 1$$

(xi) Edwards air pump removes air along with vapour and also the condensed water from condenser.



$$(xii) \text{ Vacuum Efficiency} = \frac{\text{Actual vacuum at steam inlet to condenser}}{(\text{Barometric pressure} - \text{Absolute pressure})}$$

$$= \frac{\text{Actual vacuum in condenser with air present}}{\text{Theoretical vacuum in condenser with no air present}}$$

(xiii) For same inlet and outlet temperature of the hot is cold fluid LMTD is greater for counter flow heat exchanger than parallel flow heat exchanger.

Condenser efficiency is defined as =

$$\frac{\text{Temperature rise in the cooling water}}{\text{Saturation temperature correspond to condenser pressure} - \text{cooling water inlet temperature}}$$

## OBJECTIVE QUESTIONS (GATE, IES, IAS)

## Previous 20-Years GATE Questions

## Types of Heat Exchangers

**GATE-1.** In a counter flow heat exchanger, for the hot fluid the heat capacity = 2 kJ/kg K, mass flow rate = 5 kg/s, inlet temperature = 150°C, outlet temperature = 100°C. For the cold fluid, heat capacity = 4 kJ/kg K, mass flow rate = 10 kg/s, inlet temperature = 20°C. Neglecting heat transfer to the surroundings, the outlet temperature of the cold fluid in °C is:

[GATE-2003]

- (a) 7.5                      (b) 32.5                      (c) 45.5                      (d) 70.0

## Logarithmic Mean Temperature Difference (LMTD)

**GATE-2.** In a condenser, water enters at 30°C and flows at the rate 1500 kg/hr. The condensing steam is at a temperature of 120°C and cooling water leaves the condenser at 80°C. Specific heat of water is 4.187 kJ/kg K. If the overall heat transfer coefficient is 2000 W/m<sup>2</sup>K, then heat transfer area is:

[GATE-2004]

- (a) 0.707 m<sup>2</sup>              (b) 7.07 m<sup>2</sup>              (c) 70.7 m<sup>2</sup>              (d) 141.4 m<sup>2</sup>

**GATE-3.** The logarithmic mean temperature difference (LMTD) of a counterflow heat exchanger is 20°C. The cold fluid enters at 20°C and the hot fluid enters at 100°C. Mass flow rate of the cold fluid is twice that of the hot fluid. Specific heat at constant pressure of the hot fluid is twice that of the cold fluid. The exit temperature of the cold fluid

[GATE-2008]

- (a) is 40°C              (b) is 60°C              (c) is 80°C              (d) Cannot be determined

**GATE-4.** In a counter flow heat exchanger, hot fluid enters at 60°C and cold fluid leaves at 30°C. Mass flow rate of the hot fluid is 1 kg/s and that of the cold fluid is 2 kg/s. Specific heat of the hot fluid is 10 kJ/kgK and that of the cold fluid is 5 kJ/kgK. The Log Mean Temperature Difference (LMTD) for the heat exchanger in °C is:

[GATE-2007]

- (a) 15                      (b) 30                      (c) 35                      (d) 45

**GATE-5.** Hot oil is cooled from 80 to 50°C in an oil cooler which uses air as the coolant. The air temperature rises from 30 to 40°C. The designer uses a LMTD value of 26°C. The type of heat exchanger is:

[GATE-2005]

- (a) Parallel flow      (b) Double pipe      (c) Counter flow      (d) Cross flow

**GATE-6.** For the same inlet and outlet temperatures of hot and cold fluids, the Log Mean Temperature Difference (LMTD) is:

[GATE-2002]

- (a) Greater for parallel flow heat exchanger than for counter flow heat exchanger.

- (b) Greater for counter flow heat exchanger than for parallel flow heat exchanger.  
 (c) Same for both parallel and counter flow heat exchangers.  
 (d) Dependent on the properties of the fluids.

**GATE-7.** Air enters a counter flow heat exchanger at 70°C and leaves at 40°C. Water enters at 30°C and leaves at 50°C. The LMTD in degree C is:

[GATE-2000]

- (a) 5.65                      (b) 4.43                      (c) 19.52                      (d) 20.17

## Heat Exchanger Effectiveness and Number of Transfer Units (NTU)

**GATE-8.** In a certain heat exchanger, both the fluids have identical mass flow rate-specific heat product. The hot fluid enters at 76°C and leaves at 47°C and the cold fluid entering at 26°C leaves at 55°C. The effectiveness of the heat exchanger is: [GATE-1997]

**GATE-9.** In a parallel flow heat exchanger operating under steady state, the heat capacity rates (product of specific heat at constant pressure and mass flow rate) of the hot and cold fluid are equal. The hot fluid, flowing at 1 kg/s with  $C_p = 4 \text{ kJ/kgK}$ , enters the heat exchanger at 102°C while the cold fluid has an inlet temperature of 15°C. The overall heat transfer coefficient for the heat exchanger is estimated to be 1 kW/m<sup>2</sup>K and the corresponding heat transfer surface area is 5 m<sup>2</sup>. Neglect heat transfer between the heat exchanger and the ambient. The heat exchanger is characterized by the following relation:  $2\varepsilon = 1 - \exp(-2\text{NTU})$ . [GATE-2009]

The exit temperature (in °C) for - the cold fluid is:

- (a) 45                      (b) 55                      (c) 65                      (d) 75

## Previous 20-Years IES Questions

### Types of Heat Exchangers

- IES-1.** Air can be best heated by steam in a heat exchanger of [IES-2006]  
 (a) Plate type                      (b) Double pipe type with fins on steam side  
 (c) Double pipe type with fins on air side    (d) Shell and tube type
- IES-2.** Which one of the following heat exchangers gives parallel straight line pattern of temperature distribution for both cold and hot fluid? [IES-2001]  
 (a) Parallel-flow with unequal heat capacities  
 (b) Counter-flow with equal heat capacities  
 (c) Parallel-flow with equal heat capacities  
 (d) Counter-flow with unequal heat capacities
- IES-3.** For a balanced counter-flow heat exchanger, the temperature profiles of the two fluids are: [IES-2010]  
 (a) Parallel and non-linear                      (b) Parallel and linear  
 (c) Linear but non-parallel                      (d) Divergent from one another

IES-4. Match List-I (Heat exchanger process) with List-II (Temperature area diagram) and select the correct answer: [IES-2004]

List-I

- A. Counter flow sensible heating 1.
- B. Parallel flow sensible heating 2.
- C. Evaporating 3.
- D. Condensing 4.

List II

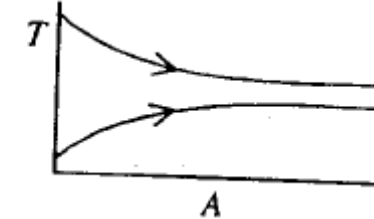
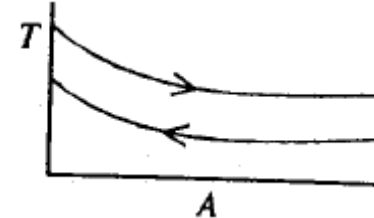
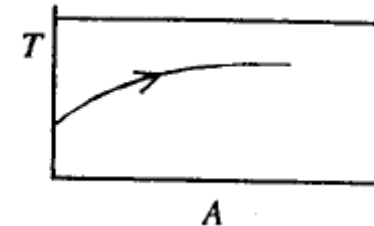
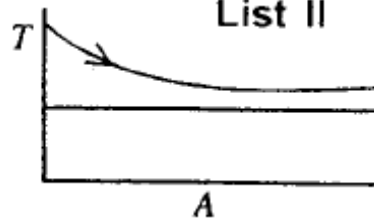

Codes:	A	B	C	D		A	B	C	D
(a)	3	4	1	2	(b)	3	2	5	1
(c)	4	3	2	5	(d)	4	2	1	5

IES-5. The temperature distribution curve for a heat exchanger as shown in the figure above (with usual notations) refers to which one of the following?

- (a) Tubular parallel flow heat exchanger
- (b) Tube in tube counter flow heat exchanger
- (c) Boiler
- (d) Condenser

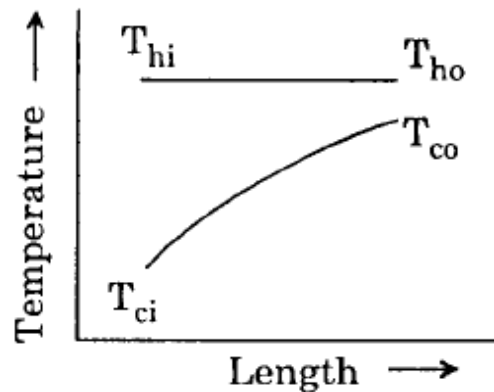

[IES-2008]

IES-6. Consider the following statements: [IES-1997]

The flow configuration in a heat exchanger, whether counterflow or otherwise, will NOT matter if:

- 1. A liquid is evaporating
- 2. A vapour is condensing
- 3. Mass flow rate of one of the fluids is far greater

Of these statements:

- (a) 1 and 2 are correct
- (b) 1 and 3 are correct

(c) 2 and 3 are correct

(d) 1, 2 and 3 are correct

IES-7. Which one of the following diagrams correctly shows the temperature distribution for a gas-to-gas counterflow heat exchanger?

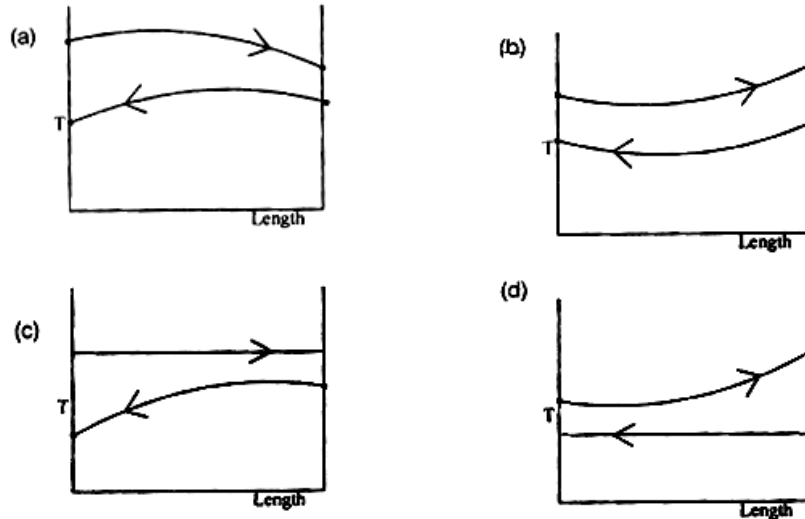

[IES-1994; 1997]

IES-8. Match List-I with List-II and select the correct answer using the codes given below the lists: [IES-1995]

List-I

- A. Regenerative heat exchanger
- B. Direct contact heat exchanger
- C. Conduction through a cylindrical wall
- D. Conduction through a spherical wall

Codes: A B C D

- (a) 1 4 2 3
- (c) 2 1 3 4

List-II

- 1. Water cooling tower
- 2. Lungstrom air heater
- 3. Hyperbolic curve
- 4. Logarithmic curve

A B C D

- (b) 3 1 4 2
- (d) 2 1 4 3

IES-9. Match List-I (Application) with List-II (Type of heat exchanger) and select the correct answer using the code given below the lists: [IES-2008]

List-I

- A. Gas to liquid
- B. Space vehicle
- C. Condenser
- D. Air pre-heater

Codes: A B C D

- (a) 2 4 3 1
- (c) 2 1 3 4

List-II

- 1. Compact
- 2. Shell and Tube
- 3. Finned tube
- 4. Regenerative

A B C D

- (b) 3 1 2 4
- (d) 3 4 2 1

IES-10. Match List-I with List-II and select the correct answer [IES-1994]

List-I

- A. Number of transfer units
- B. Periodic flow heat exchanger
- C. Chemical additive
- D. Deposition on heat exchanger surface

Codes: A B C D

- (a) 3 2 5 4

List-II

- 1. Recuperative type heat exchanger
- 2. Regenerator type heat exchanger
- 3. A measure of the heat exchanger size
- 4. Prolongs drop-wise condensation
- 5. Fouling factor

A B C D

- (b) 2 1 4 5

(c) 3 2 4 5 (d) 3 1 5 4

- IES-11. Consider the following statements: [IES-1994]  
 In a shell and tube heat exchanger, baffles are provided on the shell side to:
1. Prevent the stagnation of shell side fluid
  2. Improve heat transfer
  3. Provide support for tubes
- Select the correct answer using the codes given below:  
 (a) 1, 2, 3 and 4 (b) 1, 2 and 3 (c) 1 and 2 (d) 2 and 3
- IES-12. In a heat exchanger, the hot liquid enters with a temperature of 180°C and leaves at 160°C. The cooling fluid enters at 30°C and leaves at 110°C. The capacity ratio of the heat exchanger is: [IES-2010]  
 (a) 0.25 (b) 0.40 (c) 0.50 (d) 0.55

## Logarithmic Mean Temperature Difference (LMTD)

- IES-13. Assertion (A): It is not possible to determine LMTD in a counter flow heat exchanger with equal heat capacity rates of hot and cold fluids. Reason (R): Because the temperature difference is invariant along the length of the heat exchanger. [IES-2002]  
 (a) Both A and R are individually true and R is the correct explanation of A  
 (b) Both A and R are individually true but R is **not** the correct explanation of A  
 (c) A is true but R is false  
 (d) A is false but R is true
- IES-14. Assertion (A): A counter flow heat exchanger is thermodynamically more efficient than the parallel flow type. [IES-2003]  
 Reason (R): A counter flow heat exchanger has a lower LMTD for the same temperature conditions.  
 (a) Both A and R are individually true and R is the correct explanation of A  
 (b) Both A and R are individually true but R is **not** the correct explanation of A  
 (c) A is true but R is false  
 (d) A is false but R is true
- IES-15. In a counter-flow heat exchanger, the hot fluid is cooled from 110°C to 80°C by a cold fluid which gets heated from 30°C to 60°C. LMTD for the heat exchanger is: [IES-2001]  
 (a) 20°C (b) 30°C (c) 50°C (d) 80°C
- IES-16. Assertion (A): The LMTD for counter flow is larger than that of parallel flow for a given temperature of inlet and outlet. [IES-1998]  
 Reason (R): The definition of LMTD is the same for both counter flow and parallel flow.  
 (a) Both A and R are individually true and R is the correct explanation of A  
 (b) Both A and R are individually true but R is **not** the correct explanation of A  
 (c) A is true but R is false  
 (d) A is false but R is true
- IES-17. A counter flow heat exchanger is used to heat water from 20°C to 80°C by using hot exhaust gas entering at 140°C and leaving at 80°C. The log mean temperature difference for the heat exchanger is: [IES-1996]

- (a) 80°C (b) 60°C  
(c) 110°C (d) Not determinable as zero/zero is involved

- IES-18. For evaporators and condensers, for the given conditions, the logarithmic mean temperature difference (LMTD) for parallel flow is: [IES-1993]  
 (a) Equal to that for counter flow  
 (b) Greater than that for counter flow  
 (c) Smaller than that for counter flow  
 (d) Very much smaller than that for counter flow
- IES-19. In a counter flow heat exchanger, cold fluid enters at 30°C and leaves at 50°C, whereas the enters at 150°C and leaves at 130°C. The mean temperature difference for this case is: [IES-1994]  
 (a) Indeterminate (b) 20°C (c) 80°C (d) 100°C
- IES-20. A designer chooses the values of fluid flow ranges and specific heats in such a manner that the heat capacities of the two fluids are equal. A hot fluid enters the counter flow heat exchanger at 100°C and leaves at 60°C. The cold fluid enters the heat exchanger at 40°C. The mean temperature difference between the two fluids is: [IES-1993]  
 (a)  $(100 + 60 + 40)/3^\circ\text{C}$  (b) 60°C (c) 40°C (d) 20°C

## Overall Heat Transfer Co-efficient

- IES-21. Given the following data, [IES-1993]  
 Inside heat transfer coefficient = 25 W/m<sup>2</sup>K  
 Outside heat transfer coefficient = 25 W/m<sup>2</sup>K  
 Thermal conductivity of bricks (15 cm thick) = 0.15 W/mK,  
 The overall heat transfer coefficient (in W/m<sup>2</sup>K) will be closer to the  
 (a) Inverse of heat transfer coefficient  
 (b) Heat transfer coefficient  
 (c) Thermal conductivity of bricks  
 (d) Heat transfer coefficient based on the thermal conductivity of the bricks alone

## Heat Exchanger Effectiveness and Number of Transfer Units (NTU)

- IES-22. The 'NTU' (Number of Transfer Units) in a heat exchanger is given by which one of the following? [IES-2008]  
 (a)  $\frac{UA}{C_{\min}}$  (b)  $\frac{UA}{C_{\max}}$  (c)  $\frac{UA}{E}$  (d)  $\frac{C_{\max}}{C_{\min}}$

U = Overall heat transfer coefficient  
 E = Effectiveness

C = Heat capacity  
 A = Heat exchange area

- IES-23. When  $t_{c1}$  and  $t_{c2}$  are the temperatures of cold fluid at entry and exit respectively and  $t_{h1}$  and  $t_{h2}$  are the temperatures of hot fluid at entry and exit point, and cold fluid has lower heat capacity rate as compared to hot fluid, then effectiveness of the heat exchanger is given by:

[IES-1992]

$$(a) \frac{t_{c1} - t_{c2}}{t_{h1} - t_{c1}} \quad (b) \frac{t_{h2} - t_{h1}}{t_{c2} - t_{h1}} \quad (c) \frac{t_{h1} - t_{h2}}{t_{h2} - t_{c1}} \quad (d) \frac{t_{c2} - t_{c1}}{t_{h1} - t_{c1}}$$

IES-24. In a parallel flow gas turbine recuperator, the maximum effectiveness is: [IES-1992]

- (a) 100%                      (b) 75%                      (c) 50%                      (d) Between 25% and 45%

IES-25. In a heat exchanger with one fluid evaporating or condensing the surface area required is least in [IES-1992]

- (a) Parallel flow                      (b) Counter flow  
(c) Cross flow                      (d) Same in all above

IES-26. The equation of effectiveness  $\varepsilon = 1 - e^{-NTU}$  for a heat exchanger is valid in the case of: [IES-2006]

- (a) Boiler and condenser for parallel flow  
(b) Boiler and condenser for counter flow  
(c) Boiler and condenser for both parallel flow and counter flow  
(d) Gas turbine for both parallel flow and counter flow

IES-27. The equation of effectiveness  $\varepsilon = 1 - e^{-NTU}$  of a heat exchanger is valid (NTU is number of transfer units) in the case of: [IES-2000]

- (a) Boiler and condenser for parallel flow  
(b) Boiler and condenser for counter flow  
(c) Boiler and condenser for both parallel flow and counter flow  
(d) Gas turbine for both parallel flow and counter flow

IES-28. After expansion from a gas turbine, the hot exhaust gases are used to heat the compressed air from a compressor with the help of a cross flow compact heat exchanger of 0.8 effectiveness. What is the number of transfer units of the heat exchanger? [IES-2005]

- (a) 2                      (b) 4                      (c) 8                      (d) 16

IES-29. In a balanced counter flow heat exchanger with  $M_h C_h = M_c C_c$ , the NTU is equal to 1.0. What is the effectiveness of the heat exchanger? [IES-2009]

- (a) 0.5                      (b) 1.5                      (c) 0.33                      (d) 0.2

IES-30. In a counter flow heat exchanger, the product of specific heat and mass flow rate is same for the hot and cold fluids. If NTU is equal to 0.5, then the effectiveness of the heat exchanger is: [IES-2001]

- (a) 1.0                      (b) 0.5                      (c) 0.33                      (d) 0.2

IES-31. Match List-I with List-II and select the correct answer using the codes given below the Lists (Notations have their usual meanings): [IES-2000]

- | List-I            | List-II                           |
|-------------------|-----------------------------------|
| A. Fin            | 1. $\frac{UA}{C_{\min}}$          |
| B. Heat exchanger | 2. $\frac{x}{2\sqrt{\alpha\tau}}$ |



C. Transient conduction		3.	$\sqrt{\frac{hp}{kA}}$						
D. Heisler chart		4.	$hl/k$						
Codes:	<b>A</b>	<b>B</b>	<b>C</b>	<b>D</b>	<b>A</b>	<b>B</b>	<b>C</b>	<b>D</b>	
(a)	3	1	2	4	(b)	2	1	3	4
(c)	3	4	2	1	(d)	2	4	3	1

- IES-32. A cross-flow type air-heater has an area of 50 m<sup>2</sup>. The overall heat transfer coefficient is 100 W/m<sup>2</sup>K and heat capacity of both hot and cold stream is 1000 W/K. The value of NTU is: [IES-1999]  
 (a) 1000 (b) 500 (c) 5 (d) 0.2
- IES-33. A counter flow shell - and - tube exchanger is used to heat water with hot exhaust gases. The water ( $C_p = 4180 \text{ J/kg}^\circ\text{C}$ ) flows at a rate of 2 kg/s while the exhaust gas (1030 J/kg<sup>o</sup>C) flows at the rate of 5.25 kg/s. If the heat transfer surface area is 32.5 m<sup>2</sup> and the overall heat transfer coefficient is 200 W/m<sup>2</sup>oC, what is the NTU for the heat exchanger? [IES-1995]  
 (a) 1.2 (b) 2.4 (c) 4.5 (d) 8.6
- IES-34. A heat exchanger with heat transfer surface area  $A$  and overall heat transfer coefficient  $U$  handles two fluids of heat capacities  $C_1$ , and  $C_2$ , such that  $C_1 > C_2$ . The NTU of the heat exchanger is given by: [IES-1996]  
 (a)  $AU/C_2$  (b)  $e^{\{AU/C_2\}}$  (c)  $e^{\{AU/C_1\}}$  (d)  $AU/C_1$
- IES-35. A heat exchanger with heat transfer surface area  $A$  and overall heat transfer co-efficient  $U$  handles two fluids of heat capacities  $C_{\max}$  and  $C_{\min}$ . The parameter NTU (number of transfer units) used in the analysis of heat exchanger is specified as [IES-1993]  
 (a)  $\frac{AC_{\min}}{U}$  (b)  $\frac{U}{AC_{\min}}$  (c)  $UAC_{\min}$  (d)  $\frac{UA}{C_{\min}}$
- IES-36.  $\epsilon$ -NTU method is particularly useful in thermal design of heat exchangers when [IES-1993]  
 (a) The outlet temperature of the fluid streams is not known as a priori  
 (b) Outlet temperature of the fluid streams is known as a priori  
 (c) The outlet temperature of the hot fluid streams is known but that of the cold fluid streams is not known as a priori  
 (d) Inlet temperatures of the fluid streams are known as a priori

## Heat Pipe

- IES-37. Heat pipe is widely used now-a-days because [IES-1995]  
 (a) It acts as an insulator (b) It acts as conductor and insulator  
 (c) It acts as a superconductor (d) It acts as a fin
- IES-38. Assertion (A): Thermal conductance of heat pipe is several hundred times that of the best available metal conductor under identical conditions. [IES-2000]  
 Reason (R): The value of latent heat is far greater than that of specific heat.

- (a) Both A and R are individually true and R is the correct explanation of A
- (b) Both A and R are individually true but R is **not** the correct explanation of A
- (c) A is true but R is false
- (d) A is false but R is true

## Answers with Explanation (Objective)

## Previous 20-Years GATE Answers

**GATE-1. Ans. (b)** Let temperature  $t^\circ\text{C}$

Heat loss by hot water = heat gain by cold water

$$\dot{m}_h c_{ph} (t_{h1} - t_{h2}) = \dot{m}_c c_{pc} (t_{c2} - t_{c1})$$

$$\text{or } 5 \times 2 \times (150 - 100) = 10 \times 4 \times (t - 20)$$

$$\text{or } t = 32.5^\circ\text{C}$$

**GATE-2. Ans. (a)**  $\theta_i = 120 - 30 = 90$

$$\theta_o = 120 - 80 = 40$$

$$LMTD = \frac{\theta_i - \theta_o}{\ln\left(\frac{\theta_i}{\theta_o}\right)} = \frac{90 - 40}{\ln\left(\frac{90}{40}\right)} = 61.66^\circ\text{C}$$

$$\dot{Q} = \dot{m} c_p (t_{c2} - t_{c1}) = UA(LMTD)$$

$$\text{or } A = \frac{\left(\frac{1500}{3600}\right) \times 4.187 \times 10^3 \times (80 - 30)}{2000 \times 61.66} = 0.707 \text{ m}^2$$

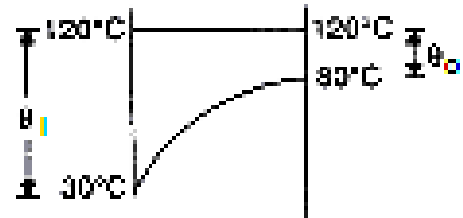

**GATE-3. Ans (c)** As  $m_h c_h = m_c c_c$ . Therefore exit temp. =  $100 - LMTD = 100 - 20 = 80^\circ\text{C}$ .

**GATE-4. Ans. (b)**

**GATE-5. Ans. (d)**

**GATE-6. Ans. (b)**

**GATE-7. Ans. (b)**  $\theta_i = 70 - 50 = 20$

$$\theta_o = 40 - 30 = 10$$

$$LMTD = \frac{\theta_i - \theta_o}{\ln\left(\frac{\theta_i}{\theta_o}\right)} = \frac{20 - 10}{\ln\left(\frac{20}{10}\right)} = 14.43^\circ$$

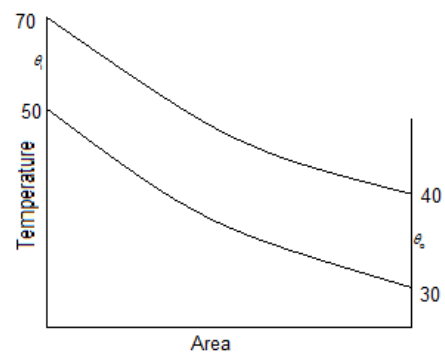

GATE-8. Ans. (b)

$$\text{Effectiveness } (\varepsilon) = \frac{Q}{Q_{\max}} = \frac{t_{c2} - t_{c1}}{t_{h1} - t_{c1}}$$

$$= \frac{55 - 26}{76 - 26} = 0.58$$

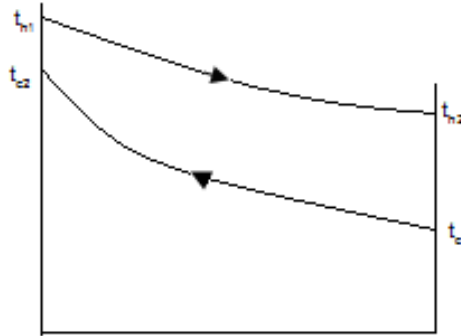

GATE-9. Ans. (b)  $\varepsilon = \frac{1 - e^{-NTU}}{2}$

and  $NTU = \frac{UA}{C_{\min}} = \frac{1000 \times 5}{4000 \times 1} = 1.25$

or  $\varepsilon = 0.459 = \frac{t_{h1} - t_{h2}}{t_{h1} - t_{c1}} = \frac{t_{c2} - t_{c1}}{t_{h1} - t_{c1}} = \frac{t_{c2} - 15}{102 - 15} \Rightarrow t_{c2} = 55$

Previous 20-Years IES Answers

IES-1. Ans. (c)

IES-2. Ans. (b)

IES-3. Ans. (a)

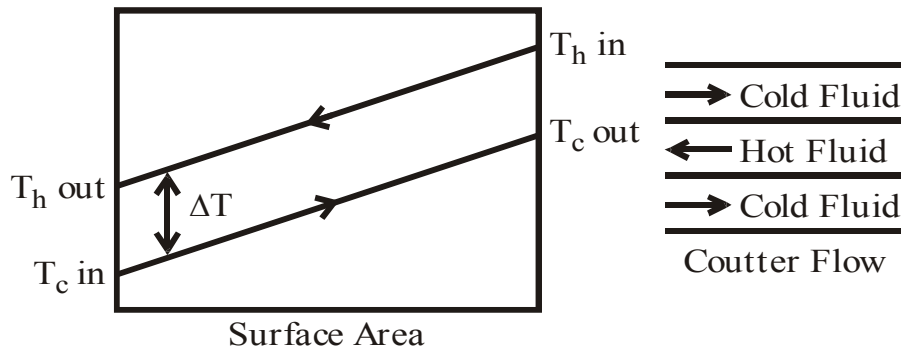

IES-4. Ans. (a)

IES-5. Ans. (d)

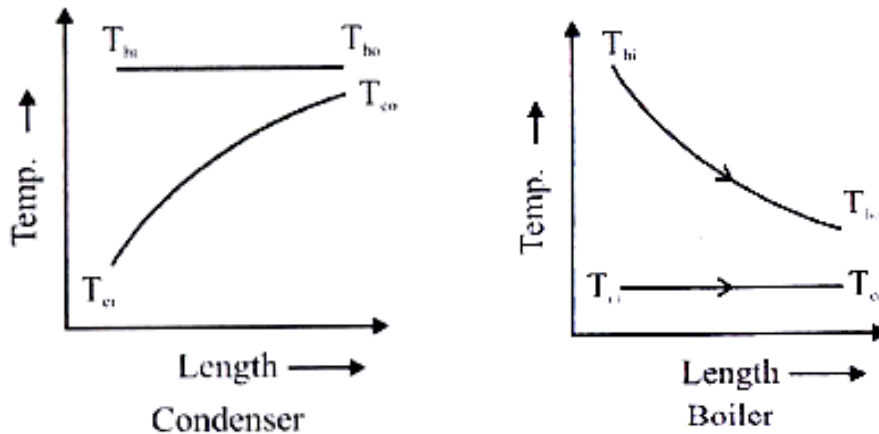

IES-6. Ans. (a) If liquid is evaporating or a vapour is condensing then whether heat exchanger is counter flow or otherwise is immaterial. Same matters for liquid/gas flows.

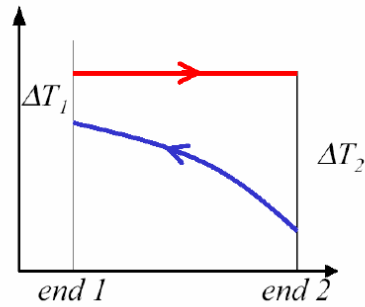

Condenser

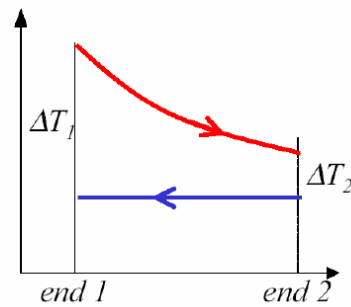

Evaporator

IES-7. Ans. (b)

IES-8. Ans. (d)

IES-9. Ans. (b)

IES-10. Ans. (c)

IES-11. Ans. (d) Baffles help in improving heat transfer and also provide support for tubes.

IES-12. Ans. (a) Capacity ratio of heat exchanger =  $\frac{t_{h1} - t_{h2}}{t_{c1} - t_{c2}} = \frac{180^\circ - 160^\circ}{110^\circ - 30^\circ} = 0.25$

IES-13. Ans. (d)

IES-14. Ans. (c)

IES-15. Ans. (c)  $\theta_1 = \theta_2 = 50^\circ$

$$\theta_1 = \theta_2 = 50^\circ \theta_1 = T_{hi} = T_\infty = 110 - 60 = 50^\circ\text{C}$$

$$\theta_2 = T_{ho} = T_{ci} = 80 - 30 = 50^\circ\text{C}$$

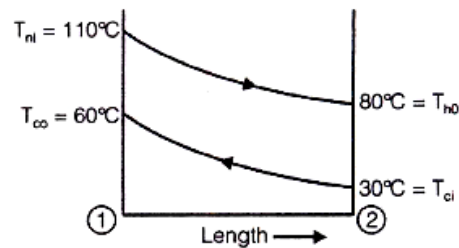

IES-16. Ans. (b) Both statements are correct but R is not exactly correct explanation for A.

IES-17. Ans. (b)

$$LMTD = \frac{\Delta t_o - \Delta t_i}{\log_e (\Delta t_o / \Delta t_i)}$$

will be applicable when  $\Delta t_i \neq \Delta t_o$  and if  $\Delta t_i = \Delta t_o$  then  $LMTD = \Delta t_i = \Delta t_o$

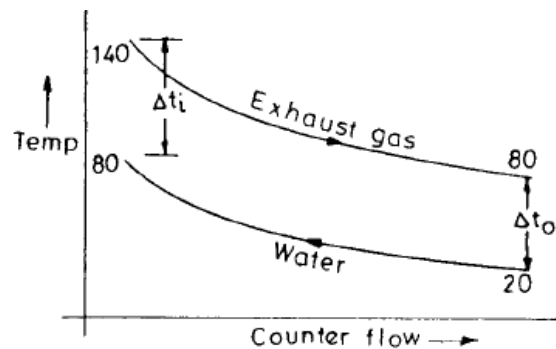

IES-18. Ans. (a)

IES-19. Ans. (d) Mean temperature difference =  
 $\Delta t_i = \Delta t_o = 100^\circ\text{C}$

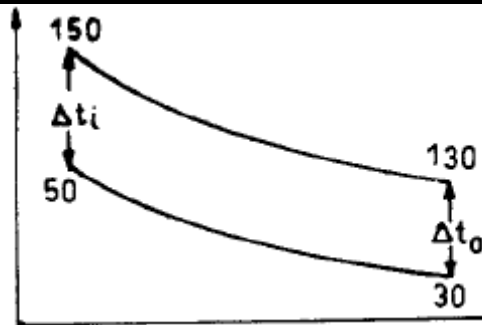

IES-20. Ans. (d) Mean temperature difference

$$= \text{Temperature of hot fluid at exit} - \text{Temperature of cold fluid at entry}$$

$$= 60^\circ - 40^\circ = 20^\circ\text{C}$$

IES-21. Ans. (d) Overall coefficient of heat transfer  $U$   $\text{W/m}^2\text{K}$  is expressed as  
 $\frac{1}{U} = \frac{1}{h_i} + \frac{\Delta x}{k} + \frac{1}{h_o} = \frac{1}{25} + \frac{0.15}{0.15} + \frac{1}{25} = \frac{27}{25}$ . So,  $U = \frac{25}{27}$  which is closer to the heat transfer coefficient based on the bricks alone.

IES-22. Ans. (a)

IES-23. Ans. (d)

IES-24. Ans. (c) For parallel flow configuration, effectiveness  $\epsilon = \frac{1 - \exp(-2NTU)}{2}$

$\therefore$  Limiting value of  $\epsilon$  is therefore  $\frac{1}{2}$  or 50%.

IES-25. Ans. (d)

IES-26. Ans. (c)  $\epsilon = \frac{1 - e^{-NTU\left(1 + \frac{C_{\min}}{C_{\max}}\right)}}{1 + \frac{C_{\min}}{C_{\max}}} = 1 - e^{-NTU}$

For Parallel flow [As boiler and condenser  $\frac{C_{\min}}{C_{\max}} \rightarrow 0$ ]

$$= \frac{1 - e^{-NTU\left(1 + \frac{C_{\min}}{C_{\max}}\right)}}{1 + \frac{C_{\min}}{C_{\max}} e^{-NTU\left(1 + \frac{C_{\min}}{C_{\max}}\right)}} = 1 - e^{-NTU} \text{ for Counter flow}$$

IES-27. Ans. (c)

IES-28. Ans. (b) Effectiveness,  $\epsilon = \frac{NTU}{1 + NTU} = 0.8$

IES-29. Ans. (a) In this case the effectiveness of the heat exchanger ( $\epsilon$ ) =  $\frac{NTU}{1 + NTU}$

IES-30. Ans. (c)

IES-31. Ans. (a)  $\text{Fin} - \sqrt{hp/kA} = m$

Heat exchanger -  $NTU = UA/C_{\min}$

Transient conduction -  $hl/k_{\text{solid}}$  (Biot No.)

Heisler chart -  $\frac{x}{2\sqrt{\alpha\tau}}$

IES-32. Ans. (c)  $NTU = \frac{AU}{C_{\min}}$ ,  $A = \text{Area} = 50\text{m}^2$

$U$  = Overall heat transfer coefficient =  $100 \text{ W/m}^2\text{K}$

$C_{\min}$  = Heat capacity =  $1000 \text{ W/K}$

$$\therefore NTU = \frac{50 \times 100}{1000} = 5$$

**IES-33. Ans. (a)**  $NTU = \frac{UA}{C_{\min}} = \frac{200 \times 32.2}{1030 \times 5.25} = 1.2$

**IES-34. Ans. (a)** NTU (number of transfer units) used in analysis of heat exchanger is specified as  $AU/C_{\min}$ .

**IES-35. Ans. (d)**

**IES-36. Ans. (a)**

**IES-37. Ans. (c)** Heat pipe can be used in different ways. Insulated portion may be made of flexible tubing to permit accommodation of different physical constraints. It can also be applied to micro-electronic circuits to maintain constant temperature. It consists of a closed pipe lined with a wicking material and containing a condensable gas. The centre portion of pipe is insulated and its two non-insulated ends respectively serve as evaporators and condensers.

Heat pipe is device used to obtain very high rates of heat flow. In practice, the thermal conductance of heat pipe may be several hundred (500) times then that best available metal conductor, hence they act as super conductor.

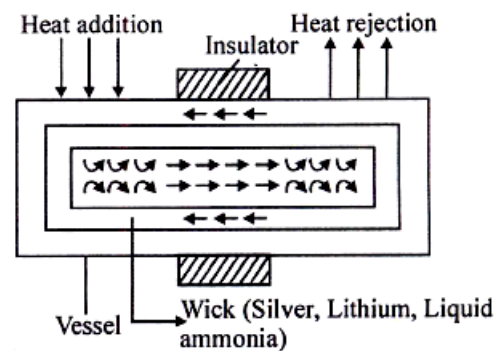

**IES-38. Ans. (a)**

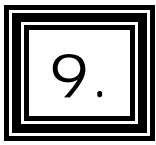

## Radiation

### Theory at a Glance (For IES, GATE, PSU)

#### Introduction

**Definition:** Radiation, energy transfer across a system boundary due to a  $\Delta T$ , by the mechanism of photon emission or electromagnetic wave emission.

Because the mechanism of transmission is photon emission, unlike conduction and convection, there need be no intermediate matter to enable transmission.

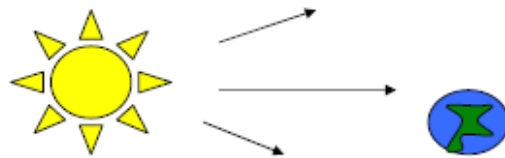

The significance of this is that radiation will be the only mechanism for heat transfer whenever a vacuum is present.

#### Electromagnetic Phenomena:

We are well acquainted with a wide range of electromagnetic phenomena in modern life. These phenomena are sometimes thought of as wave phenomena and are, consequently, often described in terms of electromagnetic wave length;  $\lambda$ . Examples are given in terms of the wave distribution shown below:

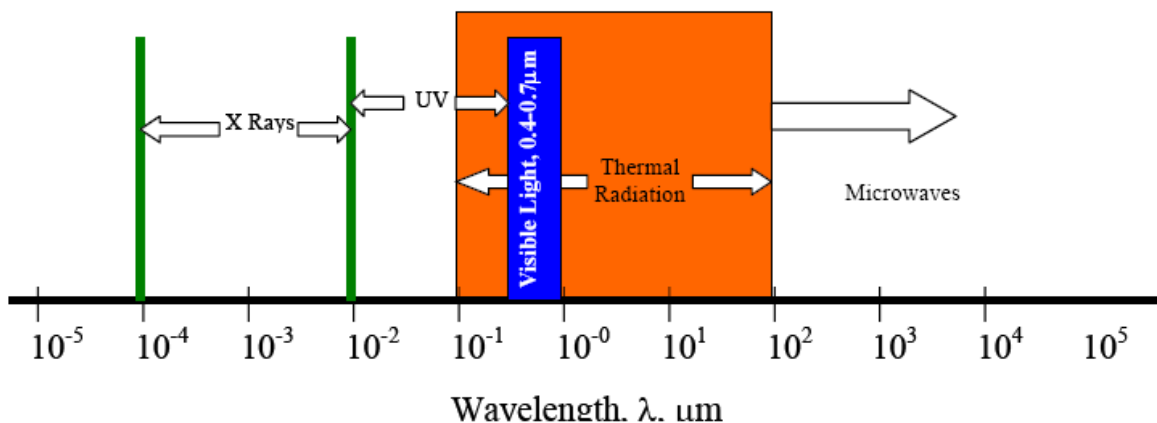

#### Solar Radiation

The magnitude of the energy leaving the Sun varies with time and is closely associated with such factors as solar flares and sunspots. Nevertheless, we often choose to work with an average value. The energy leaving the sun is emitted outward in all directions so that at any particular distance from the Sun we may imagine the energy being dispersed over an imaginary spherical area. Because this area increases with the distance squared, the solar flux also decreases with the distance squared. At the average distance between Earth



and Sun this heat flux is  $1353 \text{ W/m}^2$ , so that the average heat Flux on any object in Earth orbit is found as:

$$G_{s.o} = S_c \cdot f \cdot \cos\theta$$

Where ,

$S_c$  =Solar Constant,  $1353 \text{ W/m}^2$

$f$  = correction factor for eccentricity in Earth Orbit,  
( $0.97 < f < 1.03$ )

$\theta$  = Angle of surface from normal to Sun.

Because of reflection and absorption in the Earth's atmosphere, this number is significantly reduced at ground level. Nevertheless, this value gives us some opportunity to estimate the potential for using solar energy, such as in photovoltaic cells.

### Some Definitions

In the previous section we introduced the Stefan-Boltzman Equation to describe radiation from an ideal surface.

$$E_b = \sigma \cdot T_{abs}^4$$

This equation provides a method of determining the total energy leaving a surface, but gives no indication of the direction in which it travels. As we continue our study, we will want to be able to calculate how heat is distributed among various objects.

For this purpose, we will introduce the radiation intensity,  $I$ , defined as the energy emitted per unit area, per unit time, per unit solid angle. Before writing an equation for this new property, we will need to define some of the terms we will be using.

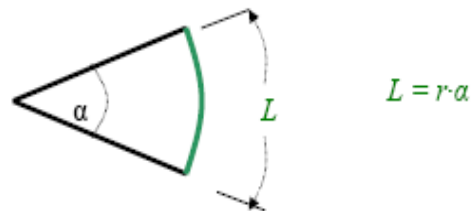

### Angles and Arc Length

We are well accustomed to thinking of an angle as a two dimensional object. It may be used to find an arc length:

### Solid Angle

We generalize the idea of an angle and an arc length to three dimensions and define a solid angle,  $\Omega$ , which like the standard angle has no dimensions. The solid angle, when multiplied by the radius squared will have dimensions of length squared, or area, and will have the magnitude of the encompassed area.

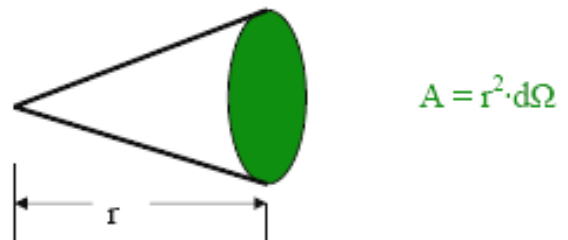

### Projected Area

The area,  $dA_1$  as seen from the prospective of a viewer, situated at an angle  $\theta$  from the normal to the surface, will appear somewhat smaller, as  $\cos \theta \cdot dA_1$ . This smaller area is termed the projected area.

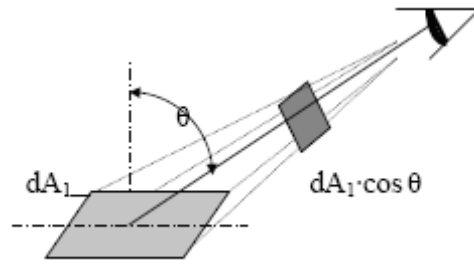

$$A_{\text{projected}} = \cos \theta \cdot A_{\text{normal}}$$

### Intensity

The ideal intensity,  $I_b$  May now is defined as the energy emitted from an ideal body, per unit projected area, per unit time, per unit solid angle.

$$I_b = \frac{dq}{\cos \theta \cdot dA_1 \cdot d\Omega}$$

### Spherical Geometry

Since any surface will emit radiation outward in all directions above the surface, the spherical coordinate system provides a convenient tool for analysis. The three basic coordinates shown are  $R$ ,  $\varphi$ , and  $\theta$ , representing the radial, azimuthally and zenith directions.

In general  $dA_1$  will correspond to the emitting surface or the source. The surface  $dA_2$  will correspond to the receiving surface or the target. Note that the area proscribed on the hemi-sphere,  $dA_2$  may be written as:

$$dA_2 = [(R \cdot \sin \theta) \cdot d\varphi] \cdot [R \cdot d\theta]$$

or, more simply as:

$$dA_2 = R^2 \cdot \sin \theta \cdot d\varphi \cdot d\theta$$

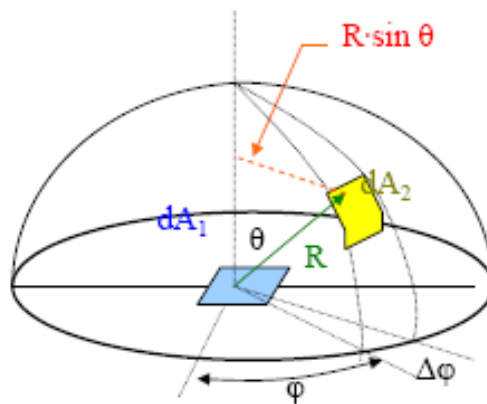

Recalling the definition of the solid angle,

$$dA = R^2 \cdot d\Omega$$

We find that:

$$d\Omega = R^2 \cdot \sin \theta \cdot d\theta \cdot d\varphi$$

### Real Surfaces

Thus far we have spoken of ideal surfaces, i.e. those that emit energy according to the Stefan-Boltzman law:

$$E_b = \sigma \cdot T_{\text{abs}}^4$$

Real surfaces have emissive powers,  $E$ , which are somewhat less than that obtained theoretically by Boltzman. To account for this reduction, we introduce the emissivity,  $(\epsilon)$ .

$$\varepsilon = \frac{E}{E_b}$$

So, that the emissive power from any real surface is given by:

$$E = \varepsilon \cdot \sigma \cdot T_{\text{abs}}^4$$

## Absorptivity, Reflectivity and Transmissivity

### Receiving Properties

Targets receive radiation in one of three ways; they absorption, reflection or transmission. To account for these characteristics, we introduce three additional properties:

- **Absorptivity**, ( $\alpha$ ), the fraction of incident radiation absorbed.
- **Reflectivity**, ( $\rho$ ), the fraction of incident radiation reflected.
- **Transmissivity**, ( $\tau$ ), the fraction of incident radiation transmitted.

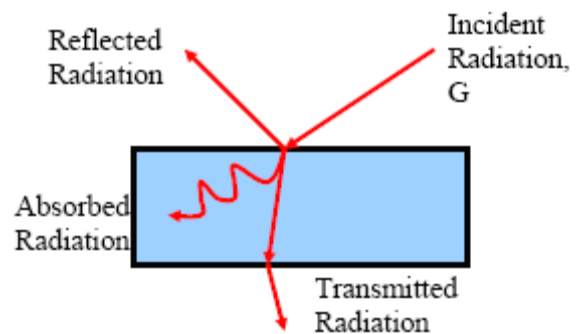

We see, from **Conservation of Energy**, that:

$$\alpha + \rho + \tau = 1$$

In this course, we will deal with only opaque surfaces,  $\tau = 0$  so that:

$$\alpha + \rho = 1 \quad \text{Opaque Surfaces}$$

**For diathermanous body,  $\alpha = 0$ ,  $\rho = 0$ ,  $\tau = 1$**

### Secular Body: Mirror Like Reflection

**For a black body,  $\mathcal{E} = 1$ , for a white body surface,  $\mathcal{E} = 0$  and**

**For gray bodies it lies between 0 and 1. It may vary with temperature or wavelength. A grey surface is one whose emissivity is independent of wavelength**

**A colored body** is one whose absorptivity of a surface varies with the wavelength of radiation  $\alpha \neq (\alpha)_\lambda$

### Black Body

**Black body:** For perfectly absorbing body,  $\alpha = 1, \rho = 0, \tau = 0$ . such a body is called a 'black body' (i.e., a black body is one which neither reflects nor transmits any part of the incident radiation but absorbs all of it). In practice, a perfect black body ( $\alpha = 1$ ) does not exist. However its concept is very important.

### A black body has the following properties:

- It absorbs all the incident radiation falling on it and does not transmit or reflect regardless of wavelength and direction.
- It emits maximum amount of thermal radiations at all wavelengths at any specified

Temperature.

- (iii) It is a *diffuse emitter* (i.e., the radiation emitted by a black body is independent of direction).

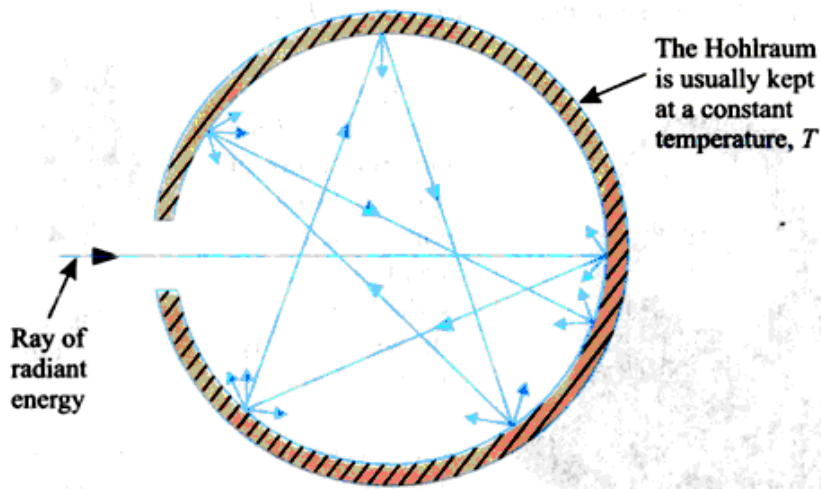

Concept of a black body

## The Stefan – Boltzmann Law

Both Stefan and Boltzman were physicists; any student taking a course in quantum physics will become well acquainted with Boltzman's work as He made a number of important contributions to the field. Both were Contemporaries of Einstein so we see that the subject is of fairly recent Vintage. (Recall that the basic equation for convection heat transfer is attributed to Newton.)

$$E_b = \sigma \cdot T_{abs}^4$$

Where:  $E_b$  = Emissive Power, the gross energy emitted from an  
Idea surface per unit area, time.

$\sigma$  = Stefan Boltzman constant,  $5.67 \times 10^{-8} \text{ W / m}^2 \cdot \text{K}^4$

$T_{abs}$  = Absolute temperature of the emitting surface, K.

Take particular note of the fact that absolute temperatures are used in Radiation. It is suggested, as a matter of good practice, to convert all temperatures to the absolute scale as an initial step in all radiation problems.

## Kirchoff's Law

Relationship between Absorptivity, ( $\alpha$ ), and Emissivity, ( $\epsilon$ ) consider two flat, infinite planes, surface A and surface B, both emitting radiation toward one another. Surface B is assumed to be an ideal emitter, i.e.  $\epsilon_B = 1.0$ . Surface A will emit radiation according to the Stefan-Boltzman law as:

$$E_A = \epsilon_A \cdot \sigma \cdot T_A^4$$

And will receive radiation as:

$$G_A = \alpha_A \cdot \sigma \cdot T_B^4$$

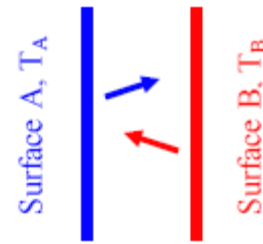

The net heat flow from surface A will be:

$$q'' = \epsilon_A \cdot \sigma \cdot T_A^4 - \alpha_A \cdot \sigma \cdot T_B^4$$

Now suppose that the two surfaces are at exactly the same temperature. The heat flow must be zero according to the 2<sup>nd</sup> law. It follows then that:

$$\alpha_A = \epsilon_A$$

Because of this close relation between emissivity, ( $\epsilon$ ), and absorptivity, ( $\alpha$ ), only one property is normally measured and this value may be used alternatively for either property.

The emissivity, ( $\epsilon$ ), of surface A will depend on the material of which surface A is composed, i.e. **aluminum, brass, steel**, etc. and on the temperature of surface A.

The absorptivity, ( $\alpha$ ), of surface A will depend on the material of which surface A is composed, i.e. aluminum, brass, steel, etc. and on the temperature of surface B.

In the design of solar collectors, engineers have long sought a material which would absorb all solar radiation, ( $\alpha = 1$ ,  $T_{\text{sun}} \sim 5600\text{K}$ ) but would not re-radiate energy as it came to temperature ( $\epsilon \ll 1$ ,  $T_{\text{collector}} \sim 400\text{K}$ ). **NASA** developed anodized chrome, commonly called “**black chrome**” as a result of this research.

## Planck's Law

While the Stefan-Boltzman law is useful for studying overall energy emissions, it does not allow us to treat those interactions, which deal specifically with wavelength, ( $\lambda$ ). This problem was overcome by another of the modern physicists, **Max Plank, who developed a relationship for wave based emissions.**

$$E_{b\lambda} = f(\lambda)$$

We haven't yet defined the Monochromatic Emissive Power,  $E_{b\lambda}$ . An implicit definition is provided by the following equation:

$$E_b = \int_0^{\infty} E_{b\lambda} \cdot d\lambda$$

We may view this equation graphically as follows:

We plot a suitable functional relationship below:

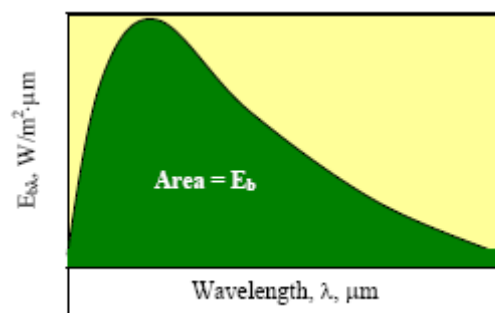
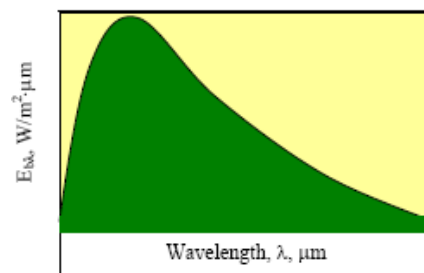

A definition of monochromatic Emissive Power would be obtained by differentiating the integral equation:

$$E_{b\lambda} \equiv \frac{dE_b}{d\lambda}$$

The actual form of Plank's law is:

$$E_{b\lambda} = \frac{C_1}{\lambda^5 \cdot \left[ e^{C_2/\lambda \cdot T} - 1 \right]}$$

where:  $C_1 = 2 \cdot \pi \cdot h \cdot c_o^2 = 3.742 \times 10^8 \text{ W} \cdot \mu\text{m}^4 / \text{m}^2$

$$C_2 = h \cdot c_o / k = 1.439 \times 10^4 \mu\text{m} \cdot \text{K}$$

where:  $h, c_o, k$  are all parameters from quantum physics. We need not worry about their precise definition here.

This equation may be solved at any  $T, \lambda$  to give the value of the monochromatic emissivity at that condition. Alternatively, the function may be substituted into the integral

$E_b = \int_0^\infty E_{b\lambda} \cdot d\lambda$  to find the Emissive power for any temperature. While performing this integral by hand is difficult, students may readily evaluate the integral through one of several computer programs, i.e. MathCAD, Maple, Mathematic, etc.

$$E_b = \int_0^\infty E_{b\lambda} \cdot d\lambda = \sigma \cdot T^4$$

### Emission over Specific Wave Length Bands

Consider the problem of designing a tanning machine. As a part of the machine, we will need to design a very powerful incandescent light source. We may wish to know how much energy is being emitted over the ultraviolet band ( $10^{-4}$  to  $0.4 \mu\text{m}$ ), known to be particularly dangerous.

$$E_b(0.0001 \rightarrow 0.4) = \int_{0.001 \cdot \mu\text{m}}^{0.4 \cdot \mu\text{m}} E_{b\lambda} \cdot d\lambda$$

With a computer available, evaluation of this integral is rather trivial. Alternatively, the text books provide a table of integrals. The format used is as follows:

$$\begin{aligned} \frac{E_b(0.001 \rightarrow 0.4)}{E_b} &= \frac{\int_{0.001 \cdot \mu\text{m}}^{0.4 \cdot \mu\text{m}} E_{b\lambda} \cdot d\lambda}{\int_0^\infty E_{b\lambda} \cdot d\lambda} = \frac{\int_0^{0.4 \cdot \mu\text{m}} E_{b\lambda} \cdot d\lambda}{\int_0^\infty E_{b\lambda} \cdot d\lambda} - \frac{\int_0^{0.0001 \cdot \mu\text{m}} E_{b\lambda} \cdot d\lambda}{\int_0^\infty E_{b\lambda} \cdot d\lambda} \\ &= F(0 \rightarrow 0.4) - F(0 \rightarrow 0.0001) \end{aligned}$$

Referring to such tables, we see the last two functions listed in the second column. In the first column is a parameter,  $\lambda \cdot T$ . This is found by taking the product of the absolute temperature of the emitting surface,  $T$ , and the upper limit wave length,  $\lambda$ . In our example, suppose that the incandescent bulb is designed to operate at a temperature of 2000K. Reading from the Table:

$\lambda, \mu\text{m}$	$T, \text{K}$	$\lambda \cdot T, \mu\text{m} \cdot \text{K}$	$F(0 \rightarrow \lambda)$
0.0001	2000	0.2	0
0.4	2000	600	0.000014
$F(0.4 \rightarrow 0.0001\mu\text{m}) = F(0 \rightarrow 0.4\mu\text{m}) - F(0 \rightarrow 0.0001\mu\text{m})$			0.000014

This is the fraction of the total energy emitted which falls within the IR band. To find the absolute energy emitted multiply this value times the total energy emitted:

$$E_{\text{bIR}} = F(0.4 \rightarrow 0.0001\mu\text{m}) \cdot \sigma \cdot T^4 = 0.000014 \times 5.67 \times 10^{-8} \times 2000^4 = 12.7\text{W/m}^2$$

## Wien Displacement Law

In 1893 Wien established a relationship between the temperature of a black body and the wavelength at which the maximum value of monochromatic emissive power occurs. A peak Monochromatic emissive power occurs at a particular wavelength. **Wien's displacement law states that the product of  $\lambda_{\text{max}}$  and  $T$  is constant, i.e.**

$$\lambda_{\text{max}} T = \text{constant}$$

$$(E_{\lambda})_b = \frac{C_1 \lambda^{-5}}{\exp\left(\frac{C_2}{\lambda T}\right) - 1}$$

$(E_{\lambda})_b$  Becomes maximum (if  $T$  remains constant) when

$$\frac{d(E_{\lambda})_b}{d\lambda} = 0$$

$$\text{i.e.} \quad \frac{d(E_{\lambda})_b}{d\lambda} = \frac{d}{d\lambda} \left[ \frac{C_1 \lambda^{-5}}{\exp\left(\frac{C_2}{\lambda T}\right) - 1} \right] = 0$$

$$\text{or,} \quad \frac{\left[ \exp\left(\frac{C_2}{\lambda T}\right) - 1 \right] (-5C_1 \lambda^{-6}) - C_1 \lambda^{-5} \left\{ \exp\left(\frac{C_2}{\lambda T}\right) \frac{C_2}{T} \left(-\frac{1}{\lambda^2}\right) \right\}}{\left[ \exp\left(\frac{C_2}{\lambda T}\right) - 1 \right]^2} = 0$$

$$\text{or,} \quad -5C_1 \lambda^{-6} \exp\left(\frac{C_2}{\lambda T}\right) + 5C_1 \lambda^{-6} + C_1 C_2 \lambda^{-5} \frac{1}{\lambda^2 T} \exp\left(\frac{C_2}{\lambda T}\right) = 0$$

Dividing both sides by  $5C_1 \lambda^{-6}$ , we get

$$-\exp\left(\frac{C_2}{\lambda T}\right) + 1 + \frac{1}{5} C_2 \frac{1}{\lambda T} \exp\left(\frac{C_2}{\lambda T}\right) = 0$$

Solving this equation by trial and error method, we get

$$\frac{C_2}{\lambda T} = \frac{C_2}{\lambda_{\max} T} = 4.965$$

$$\therefore \lambda_{\max} T = \frac{C_2}{4.965} = \frac{1.439 \times 10^4}{4.965} \mu\text{mk} = 2898 \mu\text{mk} (\approx 2900 \mu\text{mk})$$

$$\text{i.e. } \lambda_{\max} T = 2898 \mu\text{mk}$$

This law holds true for more *real substances*; there is however some deviation in the case of a metallic conductor where the product  $\lambda_{\max} T$  is found to vary with absolute temperature. It is used in *predicting a very high temperature through measurement of wavelength*.

*A combination of Planck's law and Wien's displacement law yields the condition for the maximum monochromatic emissive power for a blackbody.*

$$(E_{b\lambda})_{\max} = \frac{C_1 (\lambda_{\max})^{-5}}{\exp\left[\frac{C_2}{\lambda_{\max} T}\right] - 1} = \frac{0.374 \times 10^{-15} \left(\frac{2.898 \times 10^{-3}}{T}\right)^{-5}}{\exp\left[\frac{1.4388 \times 10^{-2}}{2.898 \times 10^{-3}}\right] - 1}$$

$$\text{or, } (E_{b\lambda})_{\max} = 1.285 \times 10^{-5} T^5 \text{ W/m}^2 \text{ per metre wavelength}$$

## Intensity of Radiation and Lambert's Cosine Law

### Relationship between Emissive Power and Intensity

By definition of the two terms, emissive power for an ideal surface, ( $E_b$ ), and intensity for an ideal surface, ( $I_b$ ).

$$E_b = \int_{\text{hemisphere}} I_b \cdot \cos \theta \cdot d\Omega$$

Replacing the solid angle by its equivalent in spherical angles:

$$E_b = \int_0^{2\pi} \int_0^{\pi/2} I_b \cdot \cos \theta \cdot \sin \theta \cdot d\theta \cdot d\phi$$

Integrate once, holding  $I_b$  constant:

$$E_b = 2\pi \cdot I_b \cdot \int_0^{\pi/2} \cos \theta \cdot \sin \theta \cdot d\theta$$

Integrate a second time (Note that the derivative of  $\sin \theta$  is  $\cos \theta \cdot d\theta$ .)

$$E_b = 2\pi \cdot I_b \cdot \left. \frac{\sin^2 \theta}{2} \right|_0^{\pi/2} = \pi \cdot I_b$$

$$\mathbf{E_b = \pi \cdot I_b}$$

## Radiation Exchange between Black Bodies Separates by a Non-absorbing Medium

### Radiation Exchange



During the previous lecture we introduced the intensity, (I), to describe radiation within a particular solid angle.

$$I = \frac{dq}{\cos \theta \cdot dA_1 \cdot d\Omega}$$

This will now be used to determine the fraction of radiation leaving a given surface and striking a second surface.

Rearranging the above equation to express the heat radiated:

$$dq = I \cdot \cos \theta \cdot dA_1 \cdot d\Omega$$

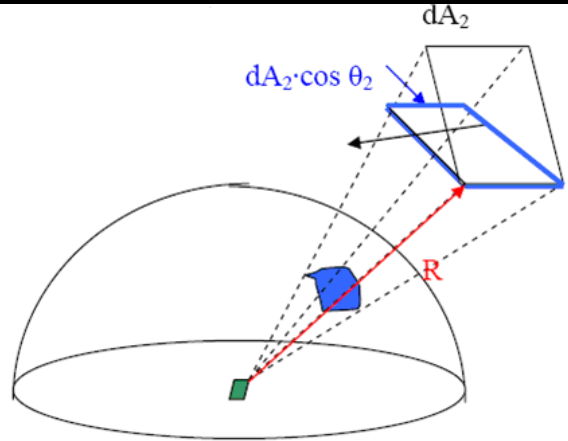

Next we will project the receiving surface onto the hemisphere surrounding the source. First find the projected area of surface,  $dA_2 \cos \theta_2$ . ( $\theta_2$  is the angle between the normal to surface 2 and the position vector, R.) Then find the solid angle,  $\Omega$ , which encompasses this area. Substituting into the heat flow equation above:

$$dq = \frac{I \cdot \cos \theta_1 \cdot dA_1 \cdot \cos \theta_2 \cdot dA_2}{R^2}$$

To obtain the entire heat transferred from a finite area,  $dA_1$ , to a finite area,  $dA_2$ , we integrate over both surfaces:

$$q_{1 \rightarrow 2} = \int_{A_2} \int_{A_1} \frac{I \cdot \cos \theta_1 \cdot dA_1 \cdot \cos \theta_2 \cdot dA_2}{R^2}$$

To express the total energy emitted from surface 1, we recall the relation between emissive power, E, and intensity, I.

$$q_{\text{emitted}} = E_1 \cdot A_1 = \pi \cdot I_1 \cdot A_1$$

### View Factors-Integral Method

Define the view factor,  $F_{1-2}$ , as the fraction of energy emitted from surface 1, which directly strikes surface 2.

$$F_{1 \rightarrow 2} = \frac{q_{1 \rightarrow 2}}{q_{\text{emitted}}} = \frac{\int_{A_2} \int_{A_1} \frac{I \cdot \cos \theta_1 \cdot dA_1 \cdot \cos \theta_2 \cdot dA_2}{R^2}}{\pi \cdot I \cdot A_1}$$

After algebraic simplification this becomes:

$$F_{1 \rightarrow 2} = \frac{1}{A_1} \cdot \int_{A_2} \int_{A_1} \frac{\cos \theta_1 \cdot \cos \theta_2 \cdot dA_1 \cdot dA_2}{\pi \cdot R^2}$$

**Example** Consider a diffuse circular disk of diameter D and area  $A_j$  and a plane diffuse surface of area  $A_i \ll A_j$ . The surfaces are parallel, and  $A_i$  is located at a distance L from the center of  $A_j$ . Obtain an expression for the view factor  $F_{ij}$ .

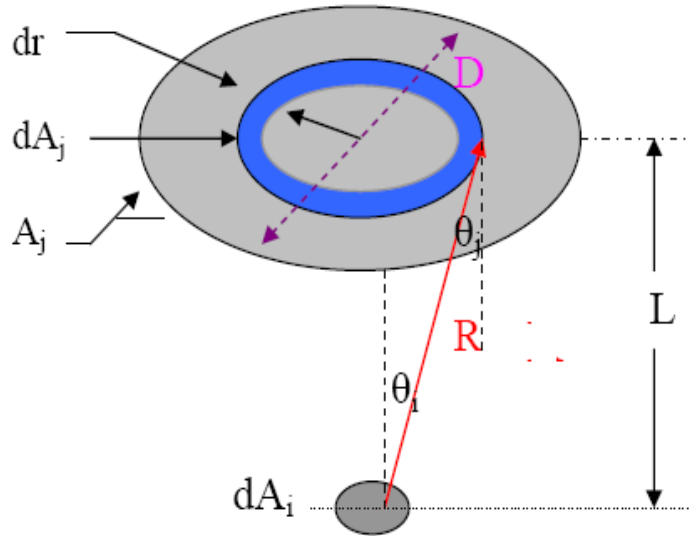

The view factor may be obtained from:

$$F_{1 \rightarrow 2} = \frac{1}{A_1} \cdot \int_{A_2} \int_{A_1} \frac{\cos \theta_1 \cdot \cos \theta_2 \cdot dA_1 \cdot dA_2}{\pi \cdot R^2}$$

Since  $dA_i$  is a differential area

$$F_{1 \rightarrow 2} = \int_{A_1} \frac{\cos \theta_1 \cdot \cos \theta_2 \cdot dA_1}{\pi \cdot R^2}$$

Substituting for the cosines and the differential area:

$$F_{1 \rightarrow 2} = \int_{A_1} \frac{\left(\frac{L}{R}\right)^2 \cdot 2\pi \cdot r \cdot dr}{\pi \cdot R^2}$$

After simplifying:

$$F_{1 \rightarrow 2} = \int_{A_1} \frac{L^2 \cdot 2\pi \cdot r \cdot dr}{R^4}$$

Let  $\rho^2 \equiv L^2 + r^2 = R^2$ . Then  $2 \cdot \rho \cdot d\rho = 2 \cdot r \cdot dr$ .

$$F_{1 \rightarrow 2} = \int_{A_1} \frac{L^2 \cdot 2\rho \cdot d\rho}{\rho^4}$$

After integrating,

$$F_{1 \rightarrow 2} = 2 \cdot L^2 \cdot \frac{\rho^2}{2} \Big|_{A_2} = -L^2 \cdot \left[ \frac{1}{L^2 + \rho^2} \right]_0^{D/2}$$

Substituting the upper & lower limits

$$F_{1 \rightarrow 2} = -L^2 \cdot \left[ \frac{4}{4 \cdot L^2 + D^2} - \frac{1}{L^2} \right]_0^{D/2} = \frac{D^2}{4 \cdot L^2 + D^2}$$

This is but one example of how the view factor may be evaluated using the integral method. The approach used here is conceptually quite straight forward; evaluating the integrals and algebraically simplifying the resulting equations can be quite lengthy.

# Shape Factor Algebra and Salient Features of the Shape Factor

1. The shape factor is purely a function of geometric parameters only.

## Enclosures

In order that we might apply conservation of energy to the radiation process, we must account for all energy leaving a surface. We imagine that the surrounding surfaces act as an enclosure about the heat source which receives all emitted energy. Should there be an opening in this enclosure through which energy might be lost, we place an imaginary surface across this opening to intercept this portion of the emitted energy. For an N surfaced enclosure, we can then see that:

$$\sum_{j=1}^N F_{i,j} = 1 \quad \text{This relationship is known as the " Conservation Rule"}$$

**Example:** Consider the previous problem of a small disk radiating to a larger disk placed directly above at a distance L. The view factor was shown to be given by the relationship:

$$F_{1 \rightarrow 2} = \frac{D^2}{4 \cdot L^2 + D^2}$$

Here, in order to provide an enclosure, we will define an imaginary surface 3, a truncated cone intersecting circles 1 and 2. From our conservation rule we have:

$$\sum_{j=1}^N F_{i,j} = F_{1,1} + F_{1,2} + F_{1,3}$$

Since surface 1 is not convex  $F_{1,1} = 0$ . Then:

$$F_{1 \rightarrow 3} = 1 - \frac{D^2}{4 \cdot L^2 + D^2}$$

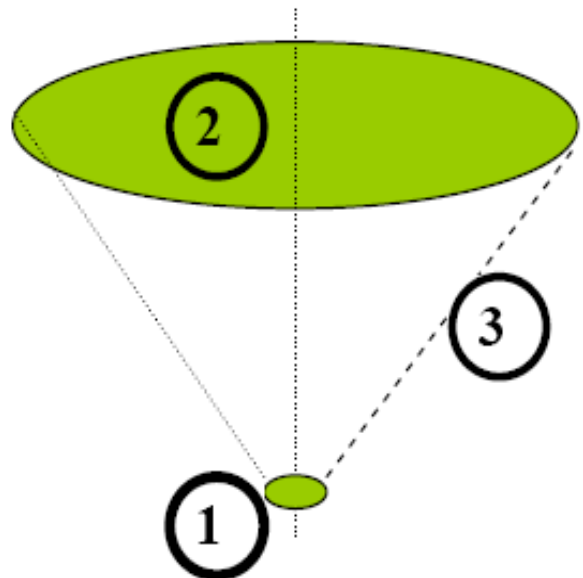

## Reciprocity

We may write the view factor from surface i to surface j as:

$$A_i \cdot F_{i \rightarrow j} = \int_{A_j} \int_{A_i} \frac{\cos \theta_i \cdot \cos \theta_j \cdot dA_i \cdot dA_j}{\pi \cdot R^2}$$

Similarly, between surfaces j and i:

$$A_j \cdot F_{j \rightarrow i} = \int_{A_i} \int_{A_j} \frac{\cos \theta_j \cdot \cos \theta_i \cdot dA_j \cdot dA_i}{\pi \cdot R^2}$$

Comparing the integrals we see that they are identical so that:

$$A_i \cdot F_{i \rightarrow j} = A_j \cdot F_{j \rightarrow i} \quad \text{This relation is known as " Reciprocity"}$$

**Example:** Consider two concentric spheres shown to the right. All radiation leaving the outside of surface 1 will strike surface 2. Part of the radiant energy leaving the inside surface of object 2 will strike surface 1, part will return to surface 2. To find the fraction of energy leaving surface 2 which strikes surface 1, we apply reciprocity:

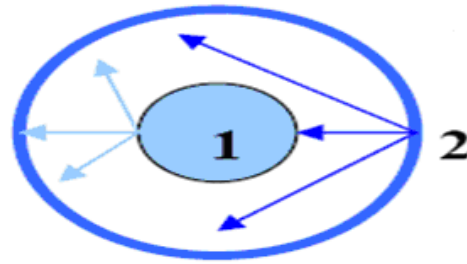

$$A_2 \cdot F_{2,1} = A_1 \cdot F_{1,2} \Rightarrow F_{2,1} = \frac{A_1}{A_2} \cdot F_{1,2} = \frac{A_1}{A_2} = \frac{D_1}{D_2}$$

### Associative Rule

Consider the set of surfaces shown to the right: Clearly, from conservation of energy, the fraction of energy leaving surface i and striking the combined surface j+k will equal the fraction of energy emitted from i and striking j plus the fraction leaving surface i and striking k.

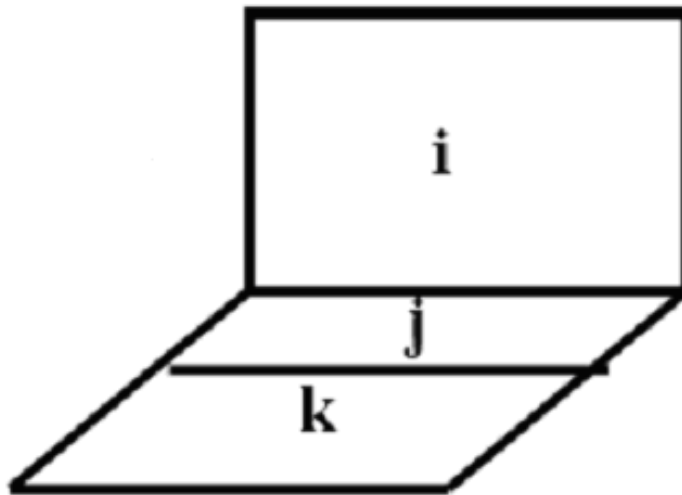

$$F_{i \rightarrow (j+k)} = F_{i \rightarrow j} + F_{i \rightarrow k}$$

This relationship is  
Known as the  
“Associative Rule”

When all the radiation emanating from a *convex surface* 1 is intercepted by the enclosing surface 2, the *shape factor of convex surface with respect to the enclosure*  $F_{1,2}$  is unity. Then in conformity with reciprocity theorem, the shape factor  $F_{2,1}$  is merely the ratio of areas. A *concave surface* has a shape factor with itself because the radiant energy coming out from one part of the surface is intercepted by the part of the same surface. *The shape factor of a surface with respect to itself is*  $F_{1-r}$ .

**(i) A black body inside a black enclosure:**



A black body inside a black enclosure

$$F_{2-1} = 1$$

...Because all radiation emanating From the black surface is intercepted By the enclosing surface 1.

$$F_{1-1} + F_{1-2} = 1$$

... By summation rule for radiation from surface 1

$$A_1 F_{1-2} = A_2 F_{2-1}$$

$$F_{1-2} = \frac{A_2}{A_1} F_{2-1}$$

... By reciprocity theorem

$$\therefore F_{1-1} = 1 - F_{1-2} = 1 - \frac{A_2}{A_1} F_{2-1} = 1 - \frac{A_2}{A_1} (\because F_{2-1} = 1)$$

Hence,  $F_{1-1} = 1 - \frac{A_2}{A_1}$  (Ans.)

**(ii) A tube with cross-section of an equilateral triangle**

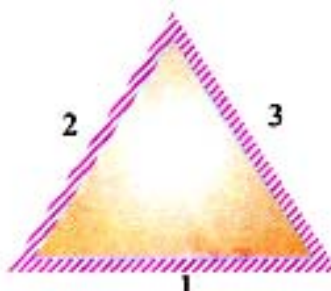

A tube with cross-section of an equilateral triangle:

$$F_{1-1} + F_{1-2} + F_{1-3} = 1$$

... By summation rule

$$F_{1-1} = 0$$

... Because the flat surface 1 cannot See itself.

$$\therefore F_{1-2} + F_{1-3} = 1$$

$$F_{1-2} = F_{1-3} = 0.5(\text{Ans.})$$

... By symmetry

Similarly, considering radiation from surface 2:

$$F_{2-1} + F_{2-2} + F_{2-3} = 1$$

or,  $F_{2-1} + F_{2-3} = 1$

( $\because F_{2-2} = 0$ )

or,  $F_{2-3} = 1 - F_{2-1}$

$$A_1 F_{1-2} = A_2 F_{2-1}$$

... By reciprocity theorem

or,  $F_{2-1} = \frac{A_1}{A_2} F_{1-2} = F_{1-2}$  ( $\because A_1 = A_2$ )

$\therefore F_{2-3} = 1 - F_{1-2} = 1 - 0.5 = 0.5$  (Ans.)

**(iii) Hemispherical surface and a plane surface**

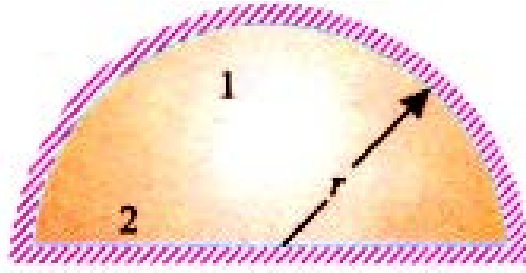

*Hemispherical surface and a plane surface:*

$F_{1-1} + F_{1-2} = 1$  ... By summation rule  
 $A_1 F_{1-2} = A_2 F_{2-1}$  ... By reciprocity theorem

or,  $F_{1-2} = \frac{A_2}{A_1} F_{2-1}$

But,  $F_{2-1} = 1$  ... Because all radiation emanating from the black surface 2 are intercepted by the enclosing Surface 1.

$\therefore F_{1-2} = \frac{A_2}{A_1} = \frac{\pi r^2}{2\pi r^2} = 0.5$  (Ans.)

Thus in case of a hemispherical surface half the radiation falls on surface 2 and the other half is intercepted by the hemisphere itself.

**(iv) Cylindrical cavity**

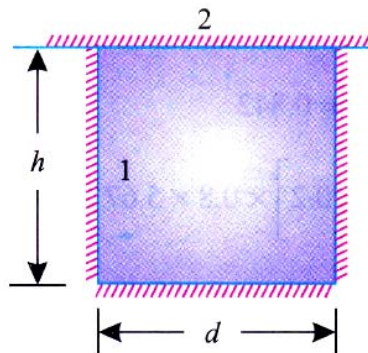

$F_{1-1} + F_{1-2} = 1$  ... By summation rule  
 or,  $F_{1-1} = 1 - F_{1-2}$   
 Also,  $F_{2-1} + F_{2-2} = 1$  ... By summation rule  
 $F_{2-2} = 0$  ... Being a flat surface (flat surface cannot see itself).  
 $F_{2-1} = 1$  ... Because all radiation emitted by the

Black surface 2 is intercepted by the Enclosing surface 1.  
... By reciprocity theorem

$$A_1 F_{1-2} = A_2 F_{2-1}$$

or, 
$$F_{1-2} = \frac{A_2}{A_1} F_{2-1} = \frac{A_2}{A_1}$$

or, 
$$F_{1-1} = 1 - F_{1-2} = 1 - \frac{A_2}{A_1}$$

or, 
$$F_{1-1} = 1 - \frac{\frac{\pi d^2}{4}}{\frac{\pi d^2}{4} + \pi d h} = 1 - \frac{d}{d + 4h} = \frac{d + 4h - d}{4h + d} = \frac{4h}{4h + d}$$

**(v) Conical cavity**

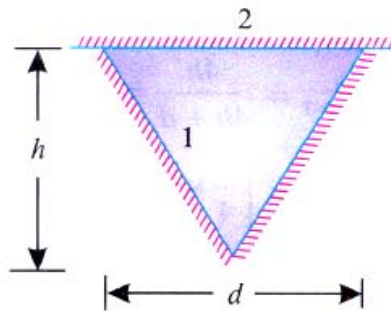

$$F_{1-1} = 1 - \frac{A_2}{A_1}$$

... This relation (calculated above) is applicable

In this case (and all such cases) also.

$$= 1 - \frac{\frac{\pi d^2}{4}}{\left[ \frac{\pi d \times \text{slant height}}{2} \right]} = 1 - \frac{\frac{\pi d^2}{4}}{\frac{\pi d}{2} \times \left[ \sqrt{h^2 + \left(\frac{d}{2}\right)^2} \right]}$$

or, 
$$F_{1-1} = 1 - \frac{d}{\sqrt{4h^2 + d^2}}$$

**(vi) Sphere within a cube**

$$F_{11} + F_{12} = 1$$

∴  $F_{11} = 0$

$$0 + F_{12} = 1 \Rightarrow F_{12} = 1$$

$$A_1 F_{12} = A_2 F_{21}$$

$$\Rightarrow F_{21} = \frac{A_1}{A_2} = \frac{4\pi \left(\frac{D}{2}\right)^2}{6D^2} = \frac{\pi}{6}$$

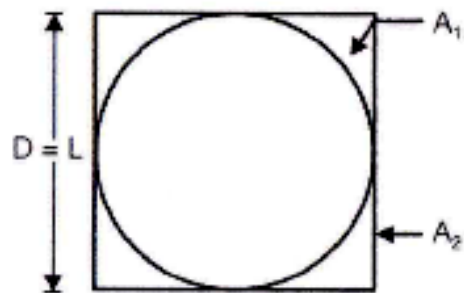

Shape Factor of Two Dimensional Elements

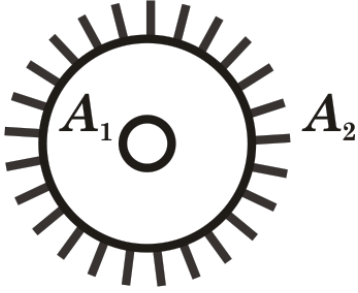
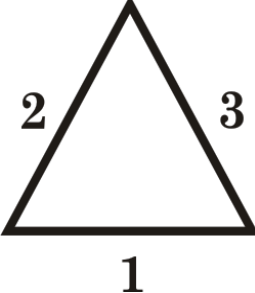
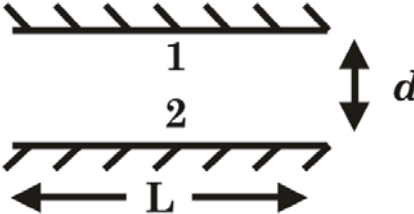
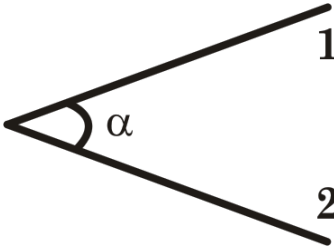
<p>1. Concentric cylinder</p>		$F_{1-2} = 1; \quad F_{2-1} = \frac{A_1}{A_2}$ $[\because A_1 F_{1-2} = A_2 F_{2-1}]$ $\therefore F_{2-2} = 1 - \frac{A_1}{A_2}$
<p>2. Long duct with equilateral triangular cross-section</p>		$F_{12} = F_{13} = \frac{1}{2}$
<p>3. Long parallel plates of equal width</p>		$F_{12} = F_{21} = \left[ 1 + \left( \frac{d}{L} \right)^2 \right]^{\frac{1}{2}} - \frac{d}{L}$
<p>4. Long symmetrical wedge</p>		$F_{12} = F_{21} = 1 - \sin \frac{\alpha}{2}$ <p style="text-align: right;">[GATE-2002]</p>

Shape Factor of Three Dimensional Elements

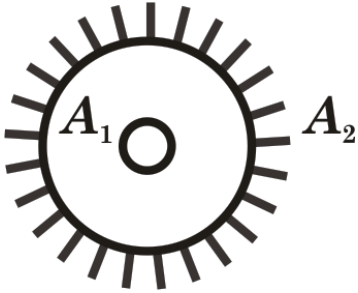
<p>5. Concentric Spheres:</p>		$F_{12} = 1, \quad F_{21} = \frac{A_1}{A_2}$ $F_{22} = 1 - F_{21} = 1 - \frac{A_1}{A_2}$
-------------------------------	---	--

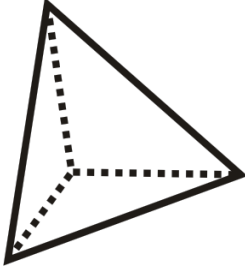
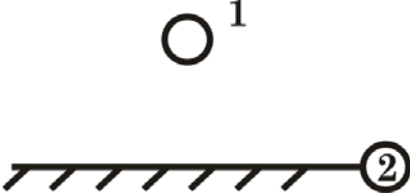
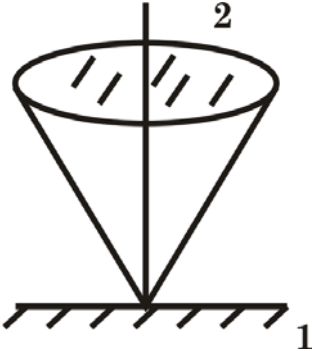
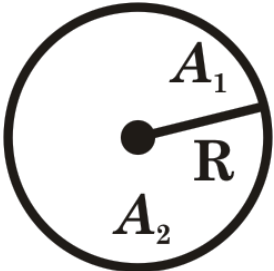

Radiation		Chapter 9
S K Mondal's		
6. Rectangular tetrahedron		$F_{12} = F_{13} = F_{14} = \frac{1}{3}$
7. Sphere near a plane area		$F_{12} = \frac{1}{2}$
8. Small area perpendicular to the axis of a surface of revolution		$F_{12} = \sin^2 \theta$
9. Area on the inside of a sphere		$F_{12} = \frac{A_2}{4\pi R^2}$

## Heat Exchange between Non-black Bodies

### Irradiation (G)

It is defined as the total radiation incident upon a surface per unit time per unit area. It is expressed in  $w/m^2$

### Radiosity (J)

This term is used to indicate the total radiation leaving a surface per unit time per unit area. It is also expressed in  $w/m^2$ .

$$J = E + \rho G$$

$$J = \epsilon E_b + \rho G$$

$E_b$  = Emissive power of a perfect black body at the same temperature.

Also,  $\alpha + \rho + \tau = 1$

or  $\alpha + \rho = 1$

( $\because \tau = 0$ , the surface being opaque)

$$\rho = 1 - \alpha$$

$$J = \epsilon E_b + (1 - \alpha) G$$

$$\alpha = \epsilon, \text{ by Kirchoff's law}$$

$$J = \epsilon E_b + (1 - \epsilon) G$$

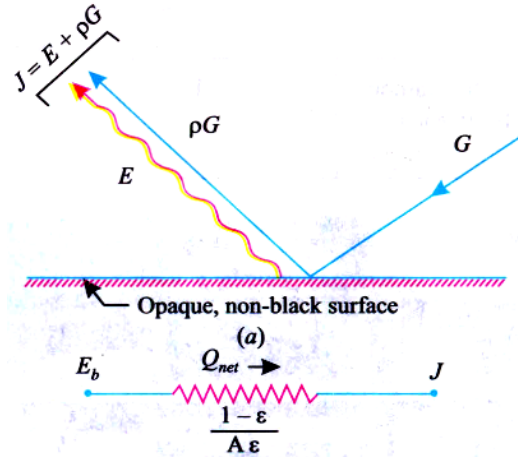

**Irradiation and Radiosity (J)**

or  $G = \frac{J - \epsilon E_b}{1 - \epsilon}$

or  $\frac{Q_{net}}{A} = J - G = J - \frac{J - \epsilon E_b}{1 - \epsilon} = \frac{E_b - J}{\frac{1 - \epsilon}{A \epsilon}}$

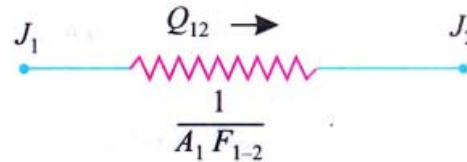

**Space resistance**

Of the total radiation which leaves surface 1, the amount that reaches 2 is  $J_1 A_1 F_{1-2}$ . Similarly the heat radiated by surface 2 and received by surface 1 is  $J_2 A_2 F_{2-1}$ .

$$Q_{12} = J_1 A_1 F_{1-2} - J_2 A_2 F_{2-1}$$

But  $A_1 F_{1-2} = A_2 F_{2-1}$

$$Q_{12} = A_1 F_{12} (J_1 - J_2) = \frac{J_1 - J_2}{\frac{1}{A_1 F_{1-2}}}$$

If the surface resistance of the two bodies and space resistance between them is considered then the net heat flow can be represented by an electric circuit.

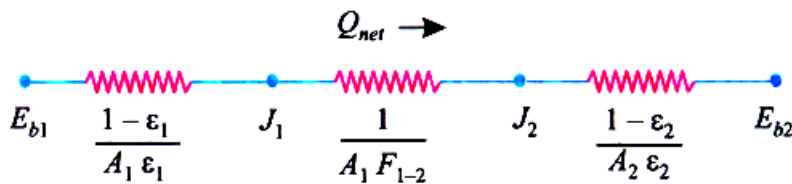

**Heat flow can be represented by an electric circuit**

$$(Q_{12})_{net} = \frac{E_{b1} - E_{b2}}{\frac{1 - \epsilon_1}{A_1 \epsilon_1} + \frac{1}{A_1 F_{1-2}} + \frac{1 - \epsilon_2}{A_2 \epsilon_2}} = \frac{A_1 \sigma (T_1^4 - T_2^4)}{\frac{1 - \epsilon_1}{\epsilon_1} + \frac{1}{F_{1-2}} + \frac{1 - \epsilon_2}{\epsilon_2} \frac{A_1}{A_2}}$$

$$\text{Heat Exchange } (Q_{12})_{net} = \sigma_b A_1 f_{12} (T_1^4 - T_2^4)$$

$$\text{Interchange factor } (f_{12}) = \frac{1}{\left(\frac{1}{\epsilon_1} - 1\right) + \frac{1}{F_{12}} + \frac{A_1}{A_2} \left(\frac{1}{\epsilon_2} - 1\right)}$$

S.No.	Cofiguraton	Geomatic factor ( $F_{1-2}$ )	Inter change factor ( $f_{1-2}$ )
1.	Infinite parallel plates	1	$f_{1-2} = \frac{1}{\frac{1}{\epsilon_1} + \frac{1}{\epsilon_2} - 1}$
2.	Infinite long concentric cylinder or Concentric spheres	1	$\frac{1}{\frac{1}{\epsilon_1} + \frac{A_1}{A_2} \left(\frac{1}{\epsilon_2} - 1\right)}$
3.	Body 1 (small) enclosed by body 2	1	$\epsilon_1$
4.	Body 1 (large) enclosed by body 2	1	$\frac{1}{\frac{1}{\epsilon_1} + \frac{A_1}{A_2} \left(\frac{1}{\epsilon_2} - 1\right)}$
5.	Two rectangles with common side at right angles to each other	1	$\epsilon_1 \epsilon_2$

**For Infinite parallel plates for black surface**

$$Q_{net} = f_{12} A \sigma (T_1^4 - T_2^4)$$

**i) Infinite parallel plates**

$$f_{12} = \frac{1}{\frac{1}{\epsilon_1} + \frac{1}{\epsilon_2} - 1}$$

$$F_{1-2} = 1 \text{ and } A_1 = A_2$$

**ii) Bodies are concentric cylinder and spheres**

$$f_{12} = 1 = \frac{1}{\frac{1 - \epsilon_1}{\epsilon_1} + 1 + \frac{1 - \epsilon_2}{\epsilon_2} \frac{A_1}{A_2}}$$

$$F_{1-2} = 1$$

**iii) A small body lies inside a large enclosure**

$$f_{1-2} = \frac{1}{\frac{1-\epsilon_1}{\epsilon_1} + 1} = \epsilon_1$$

## Electrical Network Analogy for Thermal Radiation Systems

We may develop an electrical analogy for radiation, similar to that produced for conduction. The two analogies should not be mixed: they have different dimensions on the potential differences, resistance and current flows.

	Equivalent Current	Equivalent Resistance	Potential Difference
Ohms Law	I	R	$\Delta V$
Net Energy Leaving Surface	$q_1 \rightarrow$	$\left[ \frac{1-\epsilon}{\epsilon \cdot A} \right]$	$E_b - J$
Net Exchange Between Surfaces	$q_{i \rightarrow j}$	$\frac{1}{A_1 \cdot F_{1 \rightarrow 2}}$	$J_1 - J_2$

### Solution of Analogous Electrical Circuits

- Large Enclosures

Consider the case of an object, 1, placed inside a large enclosure, 2. The system will consist of two objects, so we proceed to construct a circuit with two radiosity nodes.

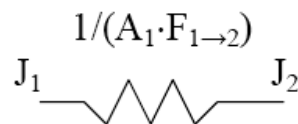

Now we ground both Radiosity nodes through a surface resistance.

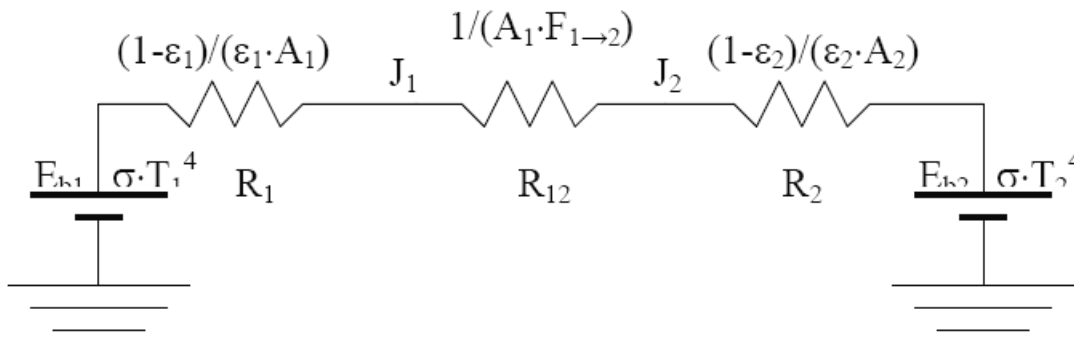

Since  $A_2$  is large,  $R_2=0$ . The view factor,  $F_{1 \rightarrow 2}=1$

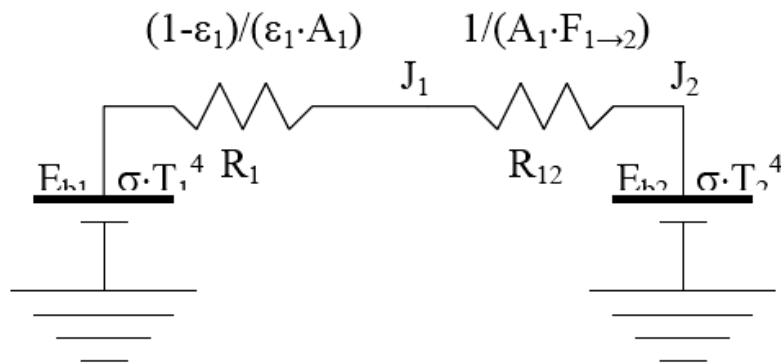

Sum the series resistances

$$R_{Series} = (1 - \epsilon) / (\epsilon_1 \cdot A_1) + 1 / A_1 = 1 / (\epsilon_1 \cdot A_1)$$

Ohm's law:

$$i = \Delta V / R$$

Or by analogy:

$$q = \Delta E_b / R_{Series} = \epsilon_1 \cdot A_1 \cdot \sigma \cdot (T_1^4 - T_2^4)$$

You may recall this result from Thermo I, where it was introduced to solve this type of radiation problem.

• **Networks with Multiple Potentials**

Systems with 3 or more grounded potentials will require a slightly different solution, but one which students have previously encountered in the Circuits course. The procedure will be to apply Kirchoff's law to each of the Radiosity junctions.

$$\sum_{i=1}^3 q_i = 0$$

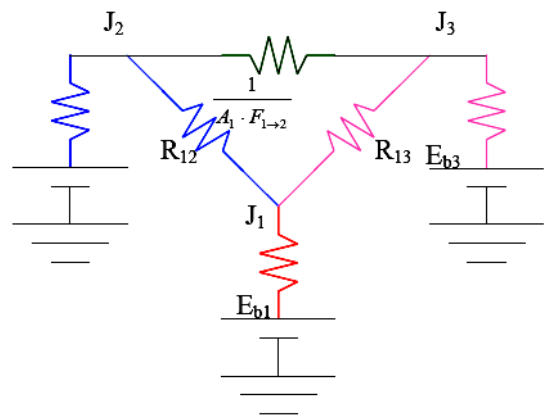

In this example there are three junctions, so we will obtain three equations. This will allow us to solve for three unknowns.

Radiation problems will generally be presented on one of two ways:

- The surface net heat flow is given and the surface temperature is to be found.
- The surface temperature is given and the net heat flow is to be found.

Returning for a moment to the coal grate furnace, let us assume that we know (a) the total heat being produced by the coal bed, (b) the temperatures of the water walls and (c) the temperature of the super heater sections.

**Apply Kirchoff's law about node 1, for the coal bed:**

$$q_1 + q_{2 \to 1} + q_{3 \to 1} = q_1 + \frac{J_2 - J_1}{R_{12}} + \frac{J_3 - J_1}{R_{13}} = 0$$

**Similarly, for node 2:**

$$q_2 + q_{1 \rightarrow 2} + q_{3 \rightarrow 2} = \frac{E_{b2} - J_2}{R_2} + \frac{J_1 - J_2}{R_{12}} + \frac{J_3 - J_2}{R_{23}} = 0$$

Note how node 1, with a specified heat input, is handled differently than node 2, with a specified temperature.

**And for node 3:**

$$q_3 + q_{1 \rightarrow 3} + q_{2 \rightarrow 3} = \frac{E_{b3} - J_3}{R_3} + \frac{J_1 - J_3}{R_{13}} + \frac{J_2 - J_3}{R_{23}} = 0$$

The three equations must be solved simultaneously. Since they are each linear in J, matrix methods may be used:

$$\begin{bmatrix} -\frac{1}{R_{12}} - \frac{1}{R_{13}} & \frac{1}{R_{12}} & \frac{1}{R_{13}} \\ \frac{1}{R_{12}} & -\frac{1}{R_2} - \frac{1}{R_{12}} - \frac{1}{R_{13}} & \frac{1}{R_{23}} \\ \frac{1}{R_{13}} & \frac{1}{R_{23}} & -\frac{1}{R_3} - \frac{1}{R_{13}} - \frac{1}{R_{23}} \end{bmatrix} \cdot \begin{bmatrix} J_1 \\ J_2 \\ J_3 \end{bmatrix} = \begin{bmatrix} -q_1 \\ -\frac{E_{b2}}{R_2} \\ \frac{E_{b3}}{R_3} \end{bmatrix}$$

The matrix may be solved for the individual Radiosity. Once these are known, we return to the electrical analogy to find the temperature of surface 1, and the heat flows to surfaces 2 and 3.

**Surface 1:** Find the coal bed temperature, given the heat flow:

$$q_1 = \frac{E_{b1} - J_1}{R_1} = \frac{\sigma \cdot T_1^4 - J_1}{R_1} \Rightarrow T_1 = \left[ \frac{q_1 \cdot R_1 + J_1}{\sigma} \right]^{0.25}$$

**Surface 2:** Find the water wall heat input, given the water wall temperature:

$$q_2 = \frac{E_{b2} - J_2}{R_2} = \frac{\sigma \cdot T_2^4 - J_2}{R_2}$$

**Surface 3:** (Similar to surface 2) Find the water wall heat input, given the water wall temperature:

$$q_3 = \frac{E_{b3} - J_3}{R_3} = \frac{\sigma \cdot T_3^4 - J_3}{R_3}$$

## Radiation Heat Exchange for Three Gray Surfaces

The network for three gray surfaces is shown in Figure below. In this case each of the body exchanges heat with the other two. The heat expressions are as follows:

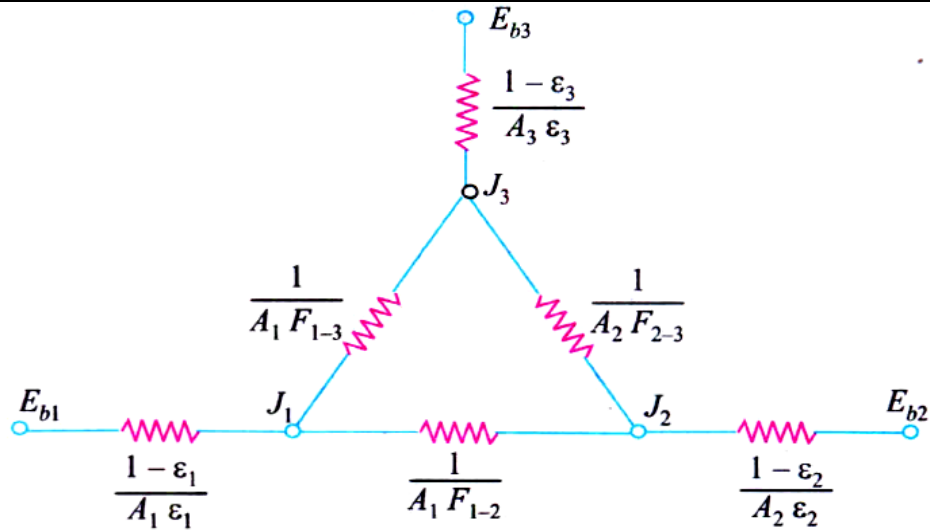

Radiation network for three gray surfaces

$$Q_{12} = \frac{J_1 - J_2}{1 / A_1 F_{1-2}}; \quad Q_{13} = \frac{J_1 - J_3}{1 / A_1 F_{1-3}}; \quad Q_{23} = \frac{J_2 - J_3}{1 / A_2 F_{2-3}}$$

The values of  $Q_{12}$ ,  $Q_{13}$  etc. are determined from the value of the radiosities which must be calculated first. The most-convenient method is the Krichhoff's law which states that the sum of the currents entering a node is zero.

### Radiation Heat Exchange for Two Black Surfaces Connected by a Single Refractory Surface

The network for two black surfaces connected by a single refractory surface is shown in the Figure below. Here the surfaces 1 and 2 are black and  $R$  is the refractory surface. The surface  $R$  is not connected to any potential as the net radiation transfer from this surface is zero.

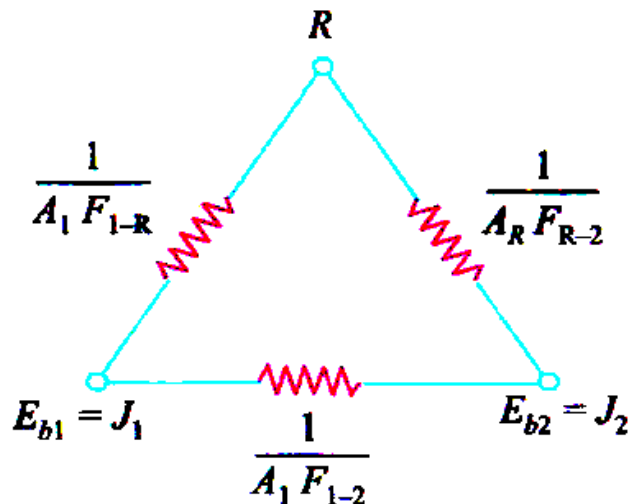

Radiation network for two black surfaces Connected by a single refractory surface

The total resistance between  $E_{b1}$  and  $E_{b2}$

$$\frac{1}{R_t} = \frac{1}{1/A_1 F_{1-2}} + \left[ \frac{1}{\frac{1}{A_1 F_{1-R}} + \frac{1}{A_R F_{R-2}}} \right]$$

or, 
$$\frac{1}{R_t} = A_1 F_{1-2} + \left[ \frac{1}{\frac{1}{A_1 F_{1-R}} + \frac{1}{A_R F_{R-2}}} \right]$$

Also 
$$F_{1-R} + F_{1-2} = 1$$
  

$$\therefore F_{1-R} = 1 - F_{1-2}$$
  

$$F_{2-R} + F_{2-1} = 1$$
  

$$\therefore F_{2-R} = 1 - F_{2-1}$$
  

$$A_R F_{R-2} = A_2 F_{2-R}$$

$$\therefore \frac{1}{R_t} = A_1 F_{1-2} + \left[ \frac{1}{\frac{1}{A_1 (1 - F_{1-2})} + \frac{1}{A_2 (1 - F_{2-1})}} \right]$$

$$\therefore (Q_{12})_{net} = (E_{b1} - E_{b2}) \left[ A_1 F_{1-2} + \left\{ \frac{1}{\frac{1}{A_1 (1 - F_{1-2})} + \frac{1}{A_2 (1 - F_{2-1})}} \right\} \right]$$

or, 
$$(Q_{12})_{net} = A_1 \bar{F}_{1-2} (E_{b1} - E_{b2}) = A_1 \bar{F}_{1-2} \sigma (T_1^4 - T_2^4)$$

$$\therefore \bar{F}_{1-2} = F_{1-2} + \left[ \frac{1}{\frac{1}{(1 - F_{1-2})} + \frac{A_1}{A_2} \left\{ \frac{1}{(1 - F_{2-1})} \right\}} \right]$$

Using reciprocity relation  $A_1 F_{1-2} = A_2 F_{2-1}$  and simplifying, we get

$$\bar{F}_{1-2} = \frac{A_2 - A_1 F_{1-2}^2}{A_1 + A_2 - 2A_1 F_{1-2}}$$

## Radiation Heat Exchange for Two Gray Surfaces Connected by Single Refractory Surface

The network for radiation heat exchange for two gray surfaces connected by single refractory surface is shown in Figure below. The third surface influences the heat transfer process because it absorbs and re-radiates energy to the other two surfaces which exchange heat. It may be noted that, in this case, the node 3 is not connected to a radiation surface resistance because surface 3 does not exchange energy.



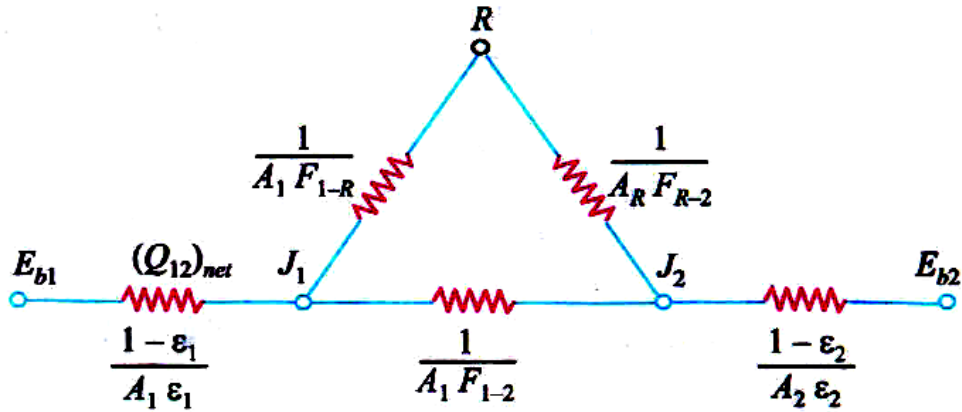

Network for two gray surfaces connected by a refractory surface

The total resistance between  $E_{b1}$  and  $E_{b2}$  is given by

$$R_t = \frac{1 - \epsilon_1}{A_1 \epsilon_1} + \frac{1 - \epsilon_2}{A_2 \epsilon_2} + \left[ \frac{1}{A_1 F_{1-2} + \frac{1}{\frac{1}{A_1 F_{1-R}} + \frac{1}{A_2 F_{R-2}}}} \right]$$

But  $F_{1-R} = 1 - F_{1-2}$  and  $F_{2-R} = 1 - F_{2-1}$

$$\therefore R_t = \frac{1 - \epsilon_1}{A_1 \epsilon_1} + \frac{1 - \epsilon_2}{A_2 \epsilon_2} + \left[ \frac{1}{A_1 F_{1-2} + \frac{1}{\frac{1}{A_1 (1 - F_{1-2})} + \frac{1}{A_2 (1 - F_{2-1})}}} \right]$$

We have

$$A_1 \bar{F}_{1-2} = A_1 F_{1-R} + \left[ \frac{1}{\frac{1}{A_1 (1 - F_{1-2})} + \frac{1}{A_2 (1 - F_{2-1})}} \right]$$

or, 
$$R_t = \frac{1 - \epsilon_1}{A_1 \epsilon_1} + \frac{1 - \epsilon_2}{A_2 \epsilon_2} + \frac{1}{A_1 \bar{F}_{1-2}}$$

$$\therefore (Q_{12})_{net} = (E_{b1} - E_{b2}) \left[ \frac{1}{\frac{1 - \epsilon_1}{A_1 \epsilon_1} + \frac{1 - \epsilon_2}{A_2 \epsilon_2} + \frac{1}{A_1 \bar{F}_{1-2}}} \right]$$

or, 
$$(Q_{12})_{net} = A_1 (E_{b1} - E_{b2}) \left[ \frac{1}{\left( \frac{1}{\epsilon_1} - 1 \right) + \frac{A_1}{A_2} \left( \frac{1}{\epsilon_2} - 1 \right) + \frac{1}{\bar{F}_{1-2}}} \right]$$

Also, 
$$(Q_{12})_{net} = A_1(F_g)_{1-2} (E_{b1} - E_{b2}) = A_1(F_g)_{1-2} \sigma(T_1^4 - T_2^4)$$

$$\therefore (F_g)_{1-2} = \left[ \frac{1}{\left(\frac{1}{\epsilon_1} - 1\right) + \frac{A_1}{A_2} \left(\frac{1}{\epsilon_2} - 1\right) + \frac{1}{F_{1-2}}} \right]$$

Where, 
$$\overline{F}_{1-2} = \frac{A_2 - A_1 F_{1-2}^2}{A_1 + A_2 - 2A_1 F_{1-2}}$$

### Radiation Heat Exchange for Four Black Surfaces

The network for radiation heat exchange for four black surfaces is shown in figure the net rate of flow from surface 1 is given by

$$(Q_1)_{net} = A_1 F_{1-2} (E_{b1} - E_{b2}) + A_1 F_{1-3} (E_{b1} - E_{b3}) + A_1 F_{1-4} (E_{b1} - E_{b4})$$

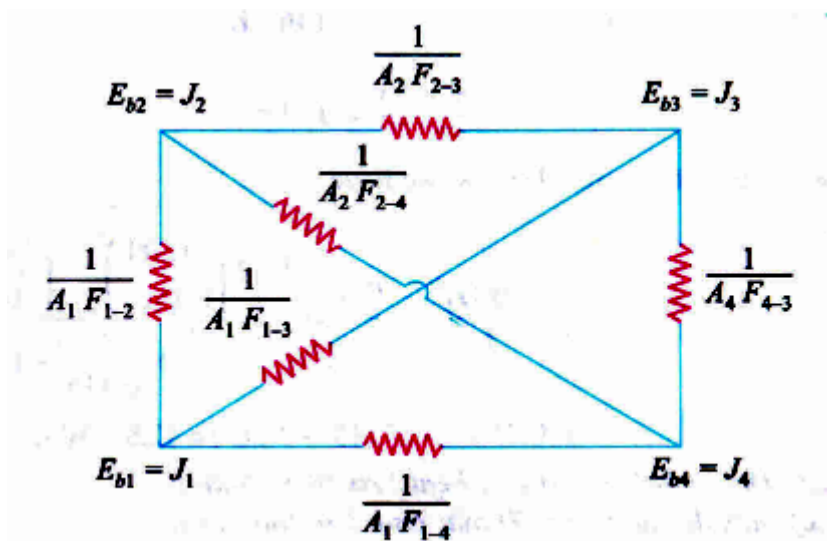

Network for four black surfaces

### Radiation Heat Exchange for Four Gray Surfaces

The network for radiation heat exchange for four gray surfaces is shown in figure below:

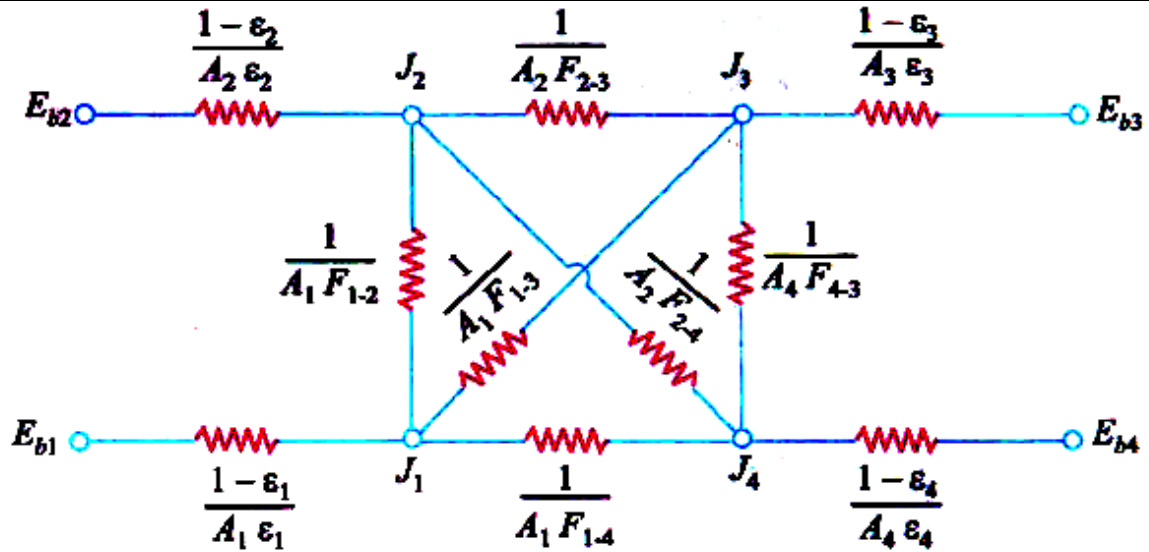

Network for four gray surfaces

The net rate of heat flow the four gray surfaces are given by:

$$(Q_1)_{net} = \frac{E_{b1} - J_1}{\frac{1 - \epsilon_1}{A_1 \epsilon_1}} = A_1 F_{1-2} (J_1 - J_2) + A_1 F_{1-3} (J_1 - J_3) + A_1 F_{1-4} (J_1 - J_4)$$

$$(Q_2)_{net} = \frac{E_{b2} - J_2}{\frac{1 - \epsilon_2}{A_2 \epsilon_2}} = A_2 F_{2-1} (J_2 - J_1) + A_2 F_{2-3} (J_2 - J_3) + A_2 F_{2-4} (J_2 - J_4)$$

$$(Q_3)_{net} = \frac{E_{b3} - J_3}{\frac{1 - \epsilon_3}{A_3 \epsilon_3}} = A_3 F_{3-1} (J_3 - J_1) + A_3 F_{3-2} (J_3 - J_2) + A_3 F_{3-4} (J_3 - J_4)$$

$$(Q_4)_{net} = \frac{E_{b4} - J_4}{\frac{1 - \epsilon_4}{A_4 \epsilon_4}} = A_4 F_{4-1} (J_4 - J_1) + A_4 F_{4-2} (J_4 - J_2) + A_4 F_{4-3} (J_4 - J_3)$$

## Radiation Shields

In certain situations it is required to reduce the overall heat transfer between two radiating surfaces. This is done by either *using materials which are highly reflective* or by *using radiation shields between the heat exchanging surfaces*. The radiation shields reduce the radiation heat transfer by effectively increasing the surface resistances without actually removing any heat from the overall system. Thin sheets of plastic coated with highly reflecting metallic films on both sides serve as very effective radiation shields. These are used for the insulation of cryogenic storage tanks. A familiar application of radiation shields is *in the measurement of the temperature of a fluid by a thermometer or a thermocouple which is shielded to reduce the effects of radiation*.

Refer Figure shown in below. Let us consider two parallel plates, 1 and 2, each of area A ( $A_1 = A_2 = A$ ) at Temperatures  $T_1$  and  $T_2$  respectively with a radiation shield placed between them as shown in figure below:

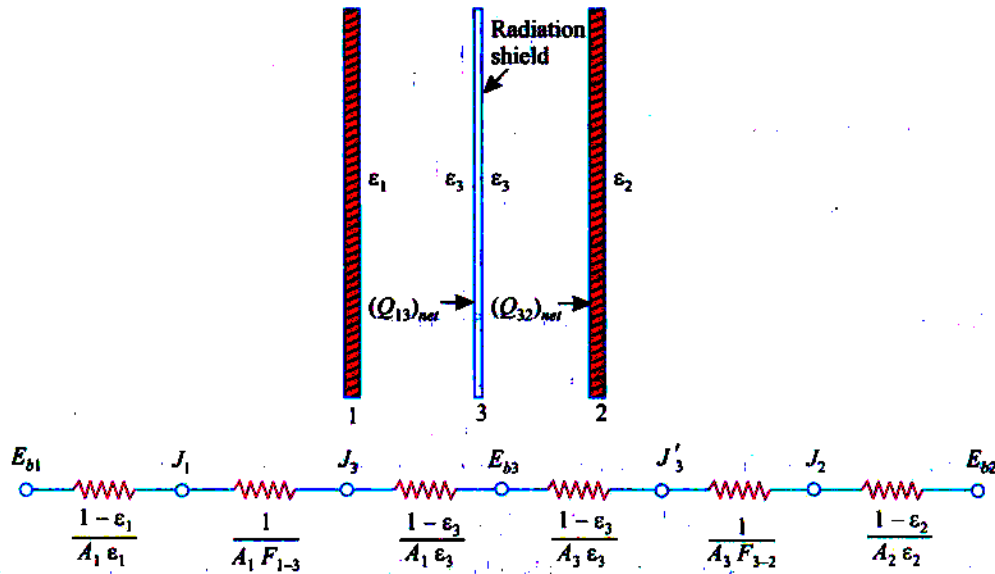

Radiation network for two parallel infinite planes separated by one shield

$$(Q_{12})_{net} = \frac{A\sigma(T_1^4 - T_2^4)}{\frac{1}{\epsilon_1} + \frac{1}{\epsilon_2} - 1}$$

$$(Q_{13})_{net} = \frac{A\sigma(T_1^4 - T_3^4)}{\frac{1}{\epsilon_1} + \frac{1}{\epsilon_3} - 1} = \frac{A\sigma(T_3^4 - T_2^4)}{\frac{1}{\epsilon_3} + \frac{1}{\epsilon_2} - 1}$$

$$(Q_{13})_{net} = (Q_{32})_{net}$$

Gives

$$T_3^4 = \frac{T_1^4 \left( \frac{1}{\epsilon_3} + \frac{1}{\epsilon_2} - 1 \right) + T_2^4 \left( \frac{1}{\epsilon_1} + \frac{1}{\epsilon_3} - 1 \right)}{\left( \frac{1}{\epsilon_3} + \frac{1}{\epsilon_2} - 1 \right) + \left( \frac{1}{\epsilon_1} + \frac{1}{\epsilon_3} - 1 \right)}$$

$$(Q_{12})_{net} = \frac{A\sigma(T_1^4 - T_2^4)}{\left( \frac{1}{\epsilon_1} + \frac{1}{\epsilon_3} - 1 \right) + \left( \frac{1}{\epsilon_3} + \frac{1}{\epsilon_2} - 1 \right)}$$

$$\frac{[(Q_{12})_{net}]_{with\ shield}}{[(Q_{12})_{net}]_{without\ shield}} = \frac{\frac{1}{\epsilon_1} + \frac{1}{\epsilon_2} - 1}{\left( \frac{1}{\epsilon_1} + \frac{1}{\epsilon_3} - 1 \right) + \left( \frac{1}{\epsilon_3} + \frac{1}{\epsilon_2} - 1 \right)} = \frac{1/f_{12}}{1/f_{13} + 1/f_{23}}$$

**n-Shield****Total resistance**

$$R_{n\text{-shield}} = \left[ (2n+2) \left( \frac{1-\varepsilon}{\varepsilon} \right) + (n+1)(1) \right] / A \quad Q_{n\text{-shield}} = \frac{1}{(n+1) \left( \frac{2}{\varepsilon} - 1 \right)} \cdot A \cdot \sigma (T_1^4 - T_2^4)$$

$$R_{\text{without shield}} = \frac{\frac{2}{\varepsilon} - 1}{A} \quad Q_{\text{without shield}} = \frac{A \sigma (T_1^4 - T_2^4)}{\frac{2}{\varepsilon} - 1}$$

$$\frac{Q_{n\text{-shields}}}{Q_{\text{without shield}}} = \frac{1}{n+1}$$

## OBJECTIVE QUESTIONS (GATE, IES, IAS)

## Previous 20-Years GATE Questions

**Absorptivity, Reflectivity and Transmissivity**

GATE-1. In radiative heat transfer, a gray surface is one [GATE-1997]

- (a) Which appears gray to the eye
- (b) Whose emissivity is independent of wavelength
- (c) Which has reflectivity equal to zero
- (d) Which appears equally bright from all directions.

**The Stefan-Boltzmann Law****Common Data for Questions Q2 and Q3:**

Radiative heat transfer is intended between the inner surfaces of two very large isothermal parallel metal plates. While the upper plate (designated as plate 1) is a black surface and is the warmer one being maintained at  $727^\circ\text{C}$ , the lower plate (plate 2) is a diffuse and gray surface with an emissivity of 0.7 and is kept at  $227^\circ\text{C}$ .

Assume that the surfaces are sufficiently large to form a two-surface enclosure and steady-state conditions to exist. Stefan-Boltzmann constant is given as  $5.67 \times 10^{-8} \text{ W/m}^2\text{K}^4$ .

GATE-2. The irradiation (in  $\text{kW/m}^2$ ) for the upper plate (plate 1) is: [GATE-2009]  
 (a) 2.5 (b) 3.6 (c) 17.0 (d) 19.5

GATE-3. If plate 1 is also a diffuse and gray surface with an emissivity value of 0.8, the net radiation heat exchange (in  $\text{kW/m}^2$ ) between plate 1 and plate 2 is: [GATE-2009]  
 (a) 17.0 (b) 19.5 (c) 23.0 (d) 31.7

GATE-4. The following figure was generated from experimental data relating spectral black body emissive power to wavelength at three temperatures  $T_1$ ,  $T_2$  and  $T_3$  ( $T_1 > T_2 > T_3$ ). [GATE-2005]

The conclusion is that the measurements are:

- (a) Correct because the maxima in  $E_{b\lambda}$  show the correct trend
- (b) Correct because Planck's law is satisfied
- (c) Wrong because the Stefan Boltzmann law is not satisfied
- (d) Wrong because Wien's displacement law is not satisfied

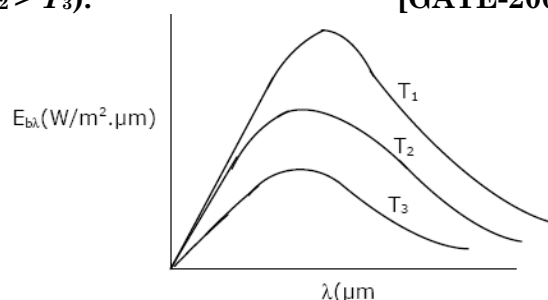

## Shape Factor Algebra and Salient Features of the Shape Factor

**GATE-5.** A hollow enclosure is formed between two infinitely long concentric cylinders of radii 1 m and 2 m, respectively. Radiative heat exchange takes place between the inner surface of the larger cylinder (surface-2) and the outer surface of the smaller cylinder (surface-1). The radiating surfaces are diffuse and the medium in the enclosure is non-participating. The fraction of the thermal radiation leaving the larger surface and striking itself is:

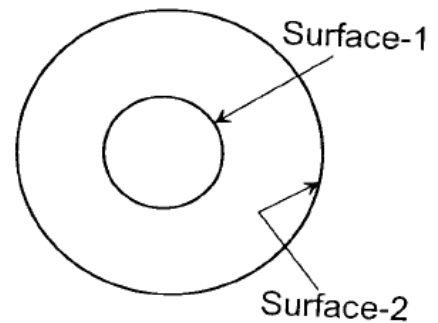

- (a) 0.25                      (b) 0.5                      (c) 0.75                      (d) 1                      [GATE-2008]

**GATE-6.** The shape factors with themselves of two infinity long black body concentric cylinders with a diameter ratio of 3 are..... for the inner and..... for the outer.                      [GATE-1994]

- (a) 0, 2/3                      (b) 0, 1/3                      (c) 1, 1/9                      (d) 1, 1/3

**GATE-7.** For the circular tube of equal length and diameter shown below, the view factor  $F_{13}$  is 0.17.

The view factor  $F_{12}$  in this case will be:

- (a) 0.17                      (b) 0.21  
(c) 0.79                      (d) 0.83

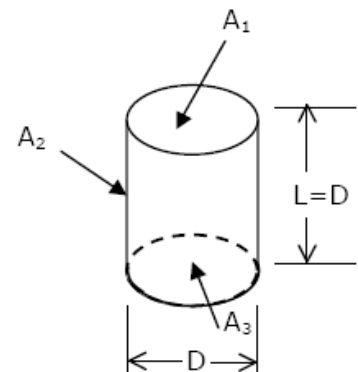

[GATE-2001]

**GATE-8.** What is the value of the view factor for two inclined flat plates having common edge of equal width, and with an angle of 20 degrees?

- (a) 0.83                      (b) 1.17                      (c) 0.66                      (d) 1.34                      [GATE-2002]

**GATE-9.** A solid cylinder (surface 2) is located at the centre of a hollow sphere (surface 1). The diameter of the sphere is 1 m, while the cylinder has a diameter and length of 0.5 m each. The radiation configuration factor  $F_{11}$  is:

- (a) 0.375                      (b) 0.625                      (c) 0.75                      (d) 1                      [GATE-2005]

## Heat Exchange between Non-black Bodies

**GATE-10.** The radiative heat transfer rate per unit area ( $\text{W/m}^2$ ) between two plane parallel grey surfaces (emissivity = 0.9) maintained at 400 K and 300 K is: [GATE-1993]

- (a) 992                      (b) 812                      (c) 464                      (d) 567  
(Stefan Boltzman constant.  $\sigma = 5.67 \times 10^{-8} \text{ W/m}^2 \text{ K}^4$ )

**GATE-11.** A plate having  $10 \text{ cm}^2$  area each side is hanging in the middle of a room of  $100 \text{ m}^2$  total surface area. The plate temperature and emissivity are respectively 800 K and 0.6. The temperature and emissivity values for the surfaces of the room are 300 K and 0.3 respectively. Boltzmann's constant  $\sigma = 5.67 \times 10^{-8} \text{ W/m}^2 \text{ K}^4$ . The total heat loss from the two surfaces of the plate is: [GATE-2003]

- (a) 13.66 W                      (b) 27.32 W                      (c) 27.87 W                      (d) 13.66 MW

## Previous 20-Years IES Questions

### Introduction

**IES-1.** Fraction of radiative energy leaving one surface that strikes the other surface is called [IES-2003]

- (a) Radiative flux                      (b) Emissive power of the first surface  
(c) View factor                      (d) Re-radiation flux

**IES-2.** Assertion (A): Heat transfer at high temperature is dominated by radiation rather than convection. [IES-2002]

Reason (R): Radiation depends on fourth power of temperature while convection depends on unit power relationship.

- (a) Both A and R are individually true and R is the correct explanation of A  
(b) Both A and R are individually true but R is **not** the of A  
(c) A is true but R is false  
(d) A is false but R is true

**IES-3.** Assertion (A): In a furnace, radiation from the walls has the same wavelength as the incident radiation from the heat source. [IES-1998]

Reason (R): Surfaces at the same temperature radiate at the same wavelength.

- (a) Both A and R are individually true and R is the correct explanation of A  
(b) Both A and R are individually true but R is **not** the correct explanation of A  
(c) A is true but R is false  
(d) A is false but R is true

**IES-4.** Consider following parameters: [IES-1995]

1. Temperature of the surface
2. Emissivity of the surface
3. Temperature of the air in the room
4. Length and diameter of the pipe

The parameter(s) responsible for loss of heat from a hot pipe surface in a room without fans would include

- (a) 1 alone                      (b) 1 and 2                      (c) 1, 2 and 3                      (d) 1, 2, 3 and 4



- IES-5. Which one of the following modes of heat transfer would take place predominantly, from boiler furnace to water wall? [IES-1993]  
 (a) Convection (b) Conduction  
 (c) Radiation (d) Conduction and convection

- IES-6. A solar engine uses a parabolic collector supplying the working fluid at  $500^{\circ}\text{C}$ . A second engine employs a flat plate collector, supplying the working fluid at  $80^{\circ}\text{C}$ . The ambient temperature is  $27^{\circ}\text{C}$ . The ratio maximum work obtainable in the two cases is: [IES-1992]  
 (a) 1 (b) 2 (c) 4 (d) 16

### Absorptivity, Reflectivity and Transmissivity

- IES-7. Consider the following statements: [IES-1998]  
 1. For metals, the value of absorptivity is high.  
 2. For non-conducting materials, reflectivity is low.  
 3. For polished surfaces, reflectivity is high.  
 4. For gases, reflectivity is very low.  
 Of these statements:  
 (a) 2, 3 and 4 are correct (b) 3 and 4 are correct  
 (c) 1, 2 and 4 are correct (d) 1 and 2 are correct

- IES-8. When  $\alpha$  is absorptivity,  $\rho$  is reflectivity and  $\tau$  is transmissivity, then for diathermanous body, which of the following relation is valid? [IES-1992]  
 (a)  $\alpha = 1, \rho = 0, \tau = 0$  (b)  $\alpha = 0, \rho = 1, \tau = 0$   
 (c)  $\alpha = 0, \rho = 0, \tau = 1$  (d)  $\alpha + \rho = 1, \tau = 0$

- IES-9. Match List-I with List-II and select the correct answer [IES-1996]
- | List-I            | List-II  |
|-------------------|--|
| A. Window glass   | 1. Emissivity independent of wavelength                            |
| B. Gray surface   | 2. Emission and absorption limited to certain bands of wavelengths |
| C. Carbon dioxide | 3. Rate at which radiation leaves a surface                        |
| D. Radiosity      | 4. Transparency to short wave radiation                            |
- | Codes: | A | B | C | D | A   | B | C | D |   |
|--------|---|---|---|---|-----|---|---|---|---|
| (a)    | 1 | 4 | 2 | 3 | (b) | 4 | 1 | 3 | 2 |
| (c)    | 4 | 1 | 2 | 3 | (d) | 1 | 4 | 3 | 2 |

- IES-10. Assertion (A): Solar Radiation is mainly scattered or transmitted but not absorbed by the atmosphere. [IES-1992]  
 Reason (R): Absorptivity of atmosphere is low.  
 (a) Both A and R are individually true and R is the correct explanation of A  
 (b) Both A and R are individually true but R is **not** the correct explanation of A  
 (c) A is true but R is false  
 (d) A is false but R is true

**Black Body**

**IES-11. Match List-I (Type of radiation) with List-II (Characteristic) and select the correct answer:** [IES-2002]

**List-I**

- A. Black body
- B. Grey body
- C. Specular
- D. Diffuse

**Codes:**

	<b>A</b>	<b>B</b>	<b>C</b>
(a)	2	1	3
(c)	2	4	3

**List-II**

- 1. Emissivity does not depend on wavelength
- 2. Mirror like reflection
- 3. Zero reflectivity
- 4. Intensity same in all directions

	<b>A</b>	<b>B</b>	<b>C</b>	<b>D</b>
(b)	3	4	2	1
(d)	3	1	2	4

**IES-12. Consider the diagram given above. Which one of the following is correct?**

- (a) Curve A is for gray body, Curve B is for black body, and Curve C is for selective emitter.
- (b) Curve A is for selective emitter, Curve B is for black body, and Curve C is for grey body.

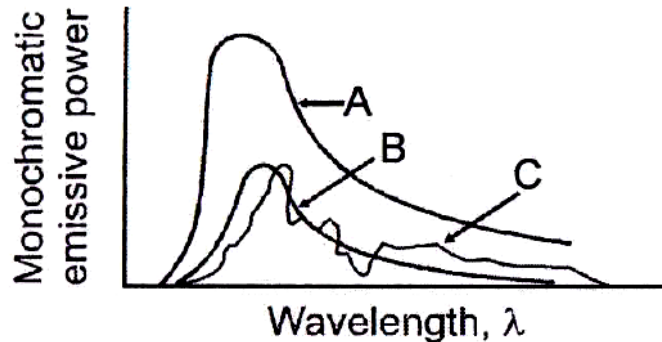

- (c) Curve A is for selective emitter, Curve B is for grey body, and Curve C is for black body.
- (d) Curve A is for black body, Curve B is for grey body, and Curve C is for selective emitter.

[IES-2007]

**IES-13. Assertion (A): The nose of aeroplane is painted black.** [IES-1996]

**Reason (R) Black body absorbs maximum heat which is generated by aerodynamic heating when the plane is flying.**

- (a) Both A and R are individually true and R is the correct explanation of A
- (b) Both A and R are individually true but R is **not** the correct explanation of A
- (c) A is true but R is false
- (d) A is false but R is true

**The Stefan-Boltzmann Law**

**IES-14. Two spheres A and B of same material have radii 1 m and 4 m and temperature 4000 K and 2000 K respectively** [IES-2004]

**Which one of the following statements is correct?**

**The energy radiated by sphere A is:**

- (a) Greater than that of sphere B
- (b) Less than that of sphere B
- (c) Equal to that of sphere B
- (d) Equal to double that of sphere B

**IES-15. A body at 500 K cools by radiating heat to ambient atmosphere maintained at 300 K. When the body has cooled to 400 K, the cooling rate as a percentage of original cooling rate is about.** [IES-2003]

- (a) 31.1
- (b) 41.5
- (c) 50.3
- (d) 80.4

**IES-16. If the temperature of a solid state changes from 27°C to 627°C, then emissive power changes which rate** [IES-1999; 2006]

- (a) 6 : 1
- (b) 9 : 1
- (c) 27 : 1
- (d) 81 : 1

- IES-17. A spherical aluminium shell of inside diameter 2 m is evacuated and used as a radiation test chamber. If the inner surface is coated with carbon black and maintained at 600 K, the irradiation on a small test surface placed inside the chamber is: [IES-1999]  
(Stefan-Boltzmann constant  $\sigma = 5.67 \times 10^{-8} \text{ W/m}^2\text{K}^4$ )  
(a) 1000 W/m<sup>2</sup>      (b) 3400 W/m<sup>2</sup>      (c) 5680 W/m<sup>2</sup>      (d) 7348 W/m<sup>2</sup>
- IES-18. A large spherical enclosure has a small opening. The rate of emission of radiative flux through this opening is 7.35 kW/m<sup>2</sup>. The temperature at the inner surface of the sphere will be about (assume Stefan Boltzmann constants  $\sigma = 5.67 \times 10^{-8} \text{ W/m}^2\text{K}^4$ ) [IES-1998]  
(a) 600 K      (b) 330 K      (c) 373 K      (d) 1000 K

### Kirchoff's Law

- IES-19. What is the ratio of thermal conductivity to electrical conductivity equal to? [IES-2006]  
(a) Prandtl number      (b) Schmidt number  
(c) Lorenz number      (d) Lewis number

- IES-20. Match List-I with List-II and select the correct answer using the code given below the lists: [IES-2008]

List-I					List-II				
A.	Heat transfer through solid	1.	Radiation heat transfer						
B.	Heat transfer from fluid	2.	Fourier's law of heat conduction						
C.	Heat transfer in boiling liquid	3.	Convection heat transfer						
D.	Heat transfer from one body to another body separated in space	4.	Newton's law of cooling						
<b>Codes:</b>	<b>A</b>	<b>B</b>	<b>C</b>	<b>D</b>	<b>A</b>	<b>B</b>	<b>C</b>	<b>D</b>	
(a)	3	1	2	4	(b)	2	4	3	1
(c)	2	1	3	4	(d)	3	4	2	1

- IES-21. Match List-I with List-II and select the correct answer using the codes given below the lists: [IES-1999]

List-I					List-II				
A.	Stefan-Boltzmann law	1.	$q = hA(T_1 - T_2)$						
B.	Newton's law of cooling	2.	$E = \alpha E_b$						
C.	Fourier's law	3.	$q = \frac{kL}{A}(T_1 - T_2)$						
D.	Kirchoff's law	4.	$q = \sigma A(T_1^4 - T_2^4)$						
		5.	$q = kA(T_1 - T_2)$						
<b>Codes:</b>	<b>A</b>	<b>B</b>	<b>C</b>	<b>D</b>	<b>A</b>	<b>B</b>	<b>C</b>	<b>D</b>	
(a)	4	1	3	2	(b)	4	5	1	2
(c)	2	1	3	4	(d)	2	5	1	4

- IES-22. Match List-I (Law) with List-II (Effect) and select the correct answer using the code given below the lists: [IES-2008]

List-I		List-II	
A.	Fourier's Law	1.	Mass transfer

- |  |  |
|--|--|
| <p>B. Stefan Boltzmann Law<br/>C. Newton's Law of Cooling<br/>D. Ficks Law</p> | <p>2. Conduction<br/>3. Convection<br/>4. Radiation</p>                    |
| <p><b>Codes:</b>    <b>A</b>      <b>B</b>      <b>C</b>      <b>D</b></p>     | <p>                 <b>A</b>      <b>B</b>      <b>C</b>      <b>D</b></p> |
| <p>(a)    3      1      2      4</p>   | <p>(b)    2      4      3      1</p>                                       |
| <p>(c)    3      4      2      1</p>   | <p>(d)    2      1      3      4</p>                                       |

### Planck's Law

- IES-23. What is the basic equation of thermal radiation from which all other equations of radiation can be derived? [IES-2007]**  
 (a) Stefan-Boltzmann equation                      (b) Planck's equation  
 (c) Wien's equation                                      (d) Rayleigh-Jeans formula
- IES-24. The spectral emissive power  $E_\lambda$  for a diffusely emitting surface is: [IES-1998]**  
 $E_\lambda = 0$     for  $\lambda < 3 \mu\text{m}$   
 $E_\lambda = 150 \text{ W/m}^2\mu\text{m}$                                       for  $3 < \lambda < 12 \mu\text{m}$   
 $E_\lambda = 300 \text{ W/m}^2\mu\text{m}$                                       for  $12 < \lambda < 25 \mu\text{m}$   
 $E_\lambda = 0$     for  $\lambda > 25 \mu\text{m}$   
**The total emissive power of the surface over the entire spectrum is:**  
 (a)  $1250 \text{ W/m}^2$       (b)  $2500 \text{ W/m}^2$       (c)  $4000 \text{ W/m}^2$       (d)  $5250 \text{ W/m}^2$
- IES-25. The wavelength of the radiation emitted by a body depends upon [IES-1992]**  
 (a) The nature of its surface                              (b) The area of its surface  
 (c) The temperature of its surface                      (d) All the above factors.

### Wien Displacement Law

- IES-26. Match List-I with List-II and select the correct answer using the code given below the lists: [IES-2005]**
- |  |  |
|--|--|
| <p><b>List-I</b></p> <p>A. Radiation heat transfer<br/>B. Conduction heat transfer<br/>C. Forced convection<br/>D. Transient heat flow</p> | <p><b>List-II</b></p> <p>1. Fourier number<br/>2. Wien displacement law<br/>3. Fourier law<br/>4. Stanton number</p> |
| <p><b>Codes:</b>    <b>A</b>      <b>B</b>      <b>C</b>      <b>D</b></p>   | <p>                 <b>A</b>      <b>B</b>      <b>C</b>      <b>D</b></p>   |
| <p>(a)    2      1      4      3</p>   | <p>(b)    4      3      2      1</p>   |
| <p>(c)    2      3      4      1</p>   | <p>(d)    4      1      2      3</p>   |
- IES-27. Sun's surface at 5800 K emits radiation at a wave-length of  $0.5 \mu\text{m}$ . A furnace at  $300^\circ\text{C}$  will emit through a small opening, radiation at a wavelength of nearly [IES-1997]**  
 (a)  $10 \mu$                       (b)  $5 \mu$                       (c)  $0.25 \mu$                       (d)  $0.025 \mu$

### Intensity of Radiation and Lambert's Cosine Law

- IES-28. Which one of the following statements is correct? [IES-2007]**  
**For a hemisphere, the solid angle is measured**  
 (a) In radian and its maximum value is  $\pi$   
 (b) In degree and its maximum value is  $180^\circ$   
 (c) In steradian and its maximum value is  $2\pi$   
 (d) In steradian and its maximum value is  $\pi$

- IES-29. Intensity of radiation at a surface in perpendicular direction is equal to: [IES-2005; 2007]
- (a) Product of emissivity of surface and  $1/\pi$   
 (b) Product of emissivity of surface and  $\pi$   
 (c) Product of emissive power of surface and  $1/\pi$   
 (d) Product of emissive power of surface and  $\pi$
- IES-30. The earth receives at its surface radiation from the sun at the rate of  $1400 \text{ W/m}^2$ . The distance of centre of sun from the surface of earth is  $1.5 \times 10^8 \text{ m}$  and the radius of sun is  $7.0 \times 10^8 \text{ m}$ . What is approximately the surface temperature of the sun treating the sun as a black body? [IES-2004]
- (a) 3650 K      (b) 4500 K      (c) 5800 K      (d) 6150 K

## Shape Factor Algebra and Salient Features of the Shape Factor

- IES-31. What is the value of the shape factor for two infinite parallel surface separated by a distance  $d$ ? [IES-2006]
- (a) 0      (b)  $\infty$       (c) 1      (d)  $d$
- IES-32. Two radiating surfaces  $A_1 = 6 \text{ m}^2$  and  $A_2 = 4 \text{ m}^2$  have the shape factor  $F_{1-2} = 0.1$ ; the shape factor  $F_{2-1}$  will be: [IES-2010]
- (a) 0.18      (b) 0.15      (c) 0.12      (d) 0.10
- IES-33. What is the shape factor of a hemispherical body placed on a flat surface with respect to itself? [IES-2005]
- (a) Zero      (b) 0.25      (c) 0.5      (d) 1.0
- IES-34. A hemispherical surface 1 lies over a horizontal plane surface 2 such that convex portion of the hemisphere is facing sky. What is the value of the geometrical shape factor  $F_{12}$ ? [IES-2004]
- (a)  $\frac{1}{4}$       (b)  $\frac{1}{2}$   
 (c)  $\frac{3}{4}$       (d)  $\frac{1}{8}$

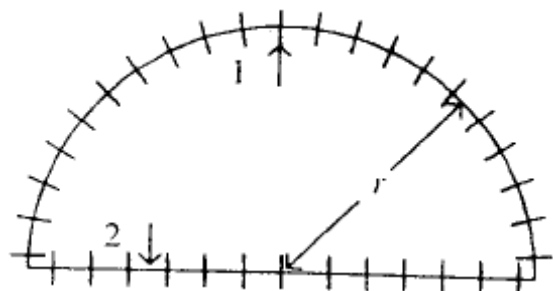

[IES-2004]

- IES-35. What will be the view factor  $F_{21}$  for the geometry as shown in the figure above (sphere within a cube)?
- (a)  $\frac{\pi}{2}$       (b)  $\frac{\pi}{4}$

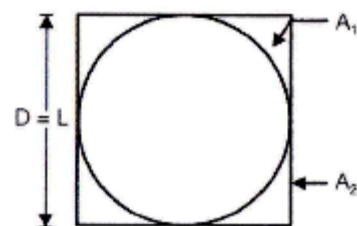

- (c)  $\frac{\pi}{3}$                       (d)  $\frac{\pi}{4}$

[IES-2009]

- IES-36.** The shape factor of a hemispherical body placed on a flat surface with respect to itself is: [IES-2001]  
 (a) Zero                      (b) 0.25                      (c) 0.5                      (d) 1.0

- IES-37.** A small sphere of outer area  $0.6 \text{ m}^2$  is totally enclosed by a large cubical hall. The shape factor of hall with respect to sphere is 0.004. What is the measure of the internal side of the cubical hall? [IES-2004]  
 (a) 4 m                      (b) 5 m                      (c) 6 m                      (d) 10 m

- IES-38.** A long semi-circular dud is shown in the given figure. What is the shape factor  $F_{22}$  for this case?  
 (a) 1.36                      (b) 0.73  
 (c) 0.56                      (d) 0.36

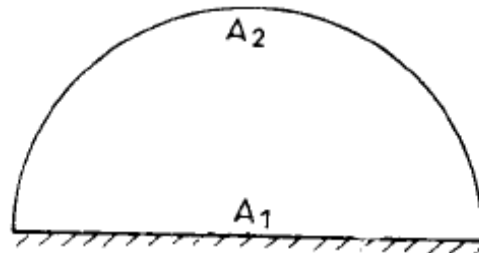

[IES-1994]

- IES-39.** Consider two infinitely long blackbody concentric cylinders with a diameter ratio  $D_2/D_1 = 3$ . The shape factor for the outer cylinder with itself will be:  
 (a) 0                      (b) 1/3  
 (c) 2/3                      (d) 1

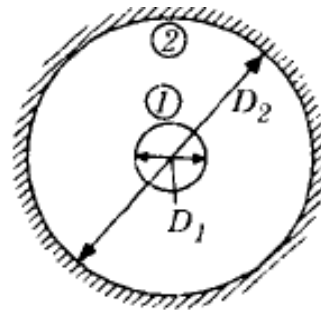

[IES-1997]

- IES-40.** Match List-I with List-II and select the correct answer using the code given below the Lists: [IES-2007]

List-I					List-II				
A. Heat Exchangers					1. View factor				
B. Turbulent flow					2. Effectiveness				
C. Free convection					3. Nusselt number				
D. Radiation heat transfer					4. Eddy diffusivity				
<b>Codes:</b>	<b>A</b>	<b>B</b>	<b>C</b>	<b>D</b>	<b>A</b>	<b>B</b>	<b>C</b>	<b>D</b>	
(a)	3	1	2	4	(b)	2	4	3	1
(c)	3	4	2	1	(d)	2	1	3	4

- IES-41.** Match List-I with List-II and select the correct answer using the code given below the lists: [IES-2006]

List-I			List-II
A. Radiation heat transfer			1. Biot's number
B. Conduction heat transfer			2. View factor

C. Forced convection					3. Fourier's law				
D. Transient heat flow					4. Stanton number				
<b>Codes:</b>	<b>A</b>	<b>B</b>	<b>C</b>	<b>D</b>	<b>A</b>	<b>B</b>	<b>C</b>	<b>D</b>	
(a)	4	3	2	1	(b)	2	1	4	3
(c)	4	1	2	3	(d)	2	3	4	1

IES-42. What is the value of the shape factor  $F_{12}$  in a cylindrical cavity of diameter  $d$  and height  $h$  between bottom face known as surface 1 and top flat surface known as surface 2?

- (a)  $\frac{2h}{2h+d}$                       (b)  $\frac{2d}{d+4h}$   
 (c)  $\frac{4d}{4d+h}$                       (d)  $\frac{2d}{2d+h}$

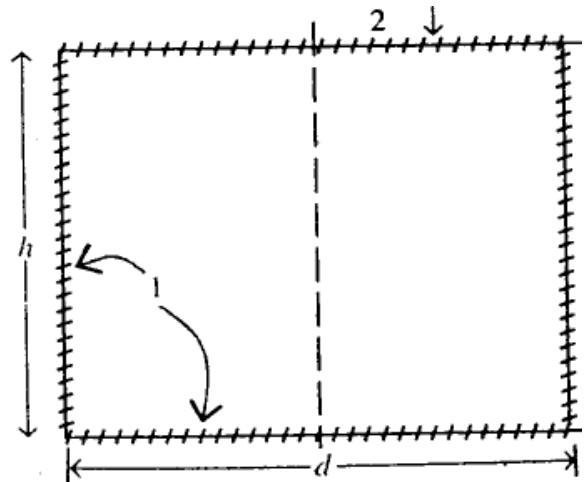

[IES-2004]

IES-43. An enclosure consists of the four surfaces 1, 2, 3 and 4. The view factors for radiation heat transfer (where the subscripts 1, 2, 3, 4 refer to the respective surfaces) are  $F_{11} = 0.1$ ,  $F_{12} = 0.4$  and  $F_{13} = 0.25$ . The surface areas  $A_1$  and  $A_4$  are  $4 \text{ m}^2$  and  $2 \text{ m}^2$  respectively. The view factor  $F_{41}$  is:

- (a) 0.75                      (b) 0.50                      (c) 0.25                      (d) 0.10

[IES-2001]

IES-44. With reference to the above figure, the shape factor between 1 and 2 is:

- (a) 0.272  
 (b) 0.34  
 (c) 0.66  
 (d) Data insufficient

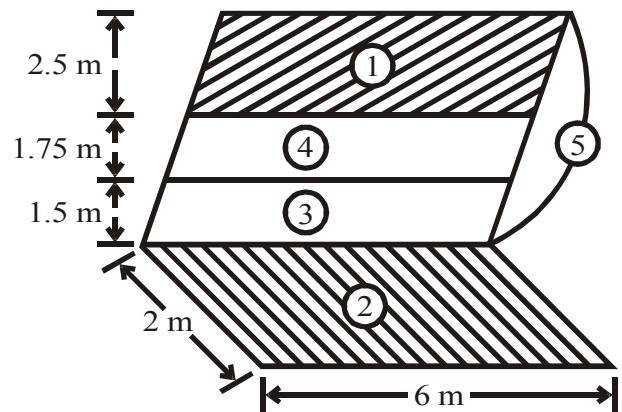

[IES-2010]

### Heat Exchange between Non-black Bodies

IES-45. Match List-I (Surface with orientations) with List-II (Equivalent emissivity) and select the correct answer: [IES-1995; 2004]

<b>List-I</b>	<b>List-II</b>
A. Infinite parallel planes	1. $\epsilon_1$

- B. Body 1 completely enclosed by body 2 but body 1 is very small      2.  $\frac{1}{\frac{1}{\epsilon_1} + \frac{1}{\epsilon_2} - 1}$
- C. Radiation exchange Between two small grey bodies      3.  $\frac{1}{\frac{1}{\epsilon_1} + \left(\frac{A_1}{A_2}\right)\left(\frac{1}{\epsilon_2} - 1\right)}$
- D. Two concentric cylinders with large lengths      4.  $\epsilon_1 \epsilon_2$

Codes:	A	B	C	D	A	B	C	D	
(a)	3	1	4	2	(b)	2	4	1	3
(c)	2	1	4	3	(d)	3	4	1	2

- IES-46.** What is the equivalent emissivity for radiant heat exchange between a small body (emissivity = 0.4) in a very large enclosure (emissivity = 0.5)? [IES-2008]
- (a) 0.5                      (b) 0.4                      (c) 0.2                      (d) 0.1
- IES-47.** The heat exchange between a small body having emissivity  $\epsilon_1$  and area  $A_1$ ; and a large enclosure having emissivity  $\epsilon_2$  and area  $A_2$  is given by  $q_{1-2} = A_1 \epsilon_1 \sigma (T_1^4 - T_2^4)$ . What is 'the assumption for this equation'? [IES-2008]
- (a)  $\epsilon_2 = 1$                       (b)  $\epsilon_2 = 0$   
 (c)  $A_1$  is very small as compared to  $A_2$   
 (d) Small body is at centre of enclosure
- IES-48.** Two large parallel grey plates with a small gap, exchange radiation at the rate of 1000 W/m<sup>2</sup> when their emissivities are 0.5 each. By coating one plate, its emissivity is reduced to 0.25. Temperature remains unchanged. The new rate of heat exchange shall become: [IES-2002]
- (a) 500 W/m<sup>2</sup>                      (b) 600 W/m<sup>2</sup>                      (c) 700 W/m<sup>2</sup>                      (d) 800 W/m<sup>2</sup>
- IES-49.** For the radiation between two infinite parallel planes of emissivity  $\epsilon_1$  and  $\epsilon_2$  respectively, which one of the following is the expression for emissivity factor? [IES-1993; 2007]
- (a)  $\epsilon_1 \epsilon_2$                       (b)  $\frac{1}{\epsilon_1} + \frac{1}{\epsilon_2}$   
 (c)  $\frac{1}{\frac{1}{\epsilon_1} + \frac{1}{\epsilon_2}}$                       (d)  $\frac{1}{\frac{1}{\epsilon_1} + \frac{1}{\epsilon_2} - 1}$
- IES-50.** The radiative heat transfer rate per unit area (W/m<sup>2</sup>) between two plane parallel grey surfaces whose emissivity is 0.9 and maintained at 400 K and 300 K is: [IES-2010]
- (a) 992                      (b) 812                      (c) 567                      (d) 464

Rate of Heat Transfer

$$q = f_{12} \cdot \sigma \cdot (T_1^4 - T_2^4) = 0.8182 \times 5.67 \times 10^{-8} (400^4 - 300^4) \text{ W/m}^2 = 812 \text{ W/m}^2$$



- IES-51. What is the net radiant interchange per square meter for two very large plates at temperatures 800 K and 500 K respectively? (The emissivity of the hot and cold plates are 0.8 and 0.6 respectively. Stefan Boltzmann constant is  $5.67 \times 10^{-8} \text{ W/m}^2 \text{ K}^4$ ). [IES-1994]  
 (a) 1.026 kW/m<sup>2</sup> (b) 10.26 kW/m<sup>2</sup> (c) 102.6 kW/m<sup>2</sup> (d) 1026 kW/m<sup>2</sup>

## Electrical Network Analogy for Thermal Radiation Systems

- IES-52. Using thermal-electrical analogy in heat transfer, match List-I (Electrical quantities) with List-II (Thermal quantities) and select the correct answer: [IES-2002]

List-I					List-II				
A. Voltage					1. Thermal resistance				
B. Current					2. Thermal capacity				
C. Resistance					3. Heat flow				
D. Capacitance					4. Temperature				
<b>Codes:</b>	<b>A</b>	<b>B</b>	<b>C</b>	<b>D</b>	<b>A</b>	<b>B</b>	<b>C</b>	<b>D</b>	<b>D</b>
(a)	2	3	1	4	(b)	4	1	3	2
(c)	2	1	3	4	(d)	4	3	1	2

- IES-53. For an opaque plane surface the irradiation, radiosity and emissive power are respectively 20, 12 and 10 W/m<sup>2</sup>. What is the emissivity of the surface? [IES-2004]  
 (a) 0.2 (b) 0.4 (c) 0.8 (d) 1.0

- IES-54. Heat transfer by radiation between two grey bodies of emissivity  $\epsilon$  is proportional to (notations have their usual meanings) [IES-2000]  
 (a)  $\frac{(E_b - J)}{(1 - \epsilon)}$  (b)  $\frac{(E_b - J)}{(1 - \epsilon) / \epsilon}$  (c)  $\frac{(E_b - J)}{(1 - \epsilon)^2}$  (d)  $\frac{(E_b - J)}{(1 - \epsilon^2)}$

- IES-55. Solar radiation of 1200 W/m<sup>2</sup> falls perpendicularly on a grey opaque surface of emissivity 0.5. If the surface temperature is 50°C and surface emissive power 600 W/m<sup>2</sup>, the radiosity of that surface will be: [IES-2000]  
 (a) 600 W/m<sup>2</sup> (b) 1000 W/m<sup>2</sup> (c) 1200 W/m<sup>2</sup> (d) 1800 W/m<sup>2</sup>

- IES-56. A pipe carrying saturated steam is covered with a layer of insulation and exposed to ambient air. [IES-1996]

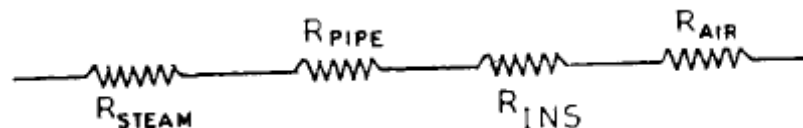

The thermal resistances are as shown in the figure. Which one of the following statements is correct in this regard?

- (a)  $R_{\text{steam}}$  and  $R_{\text{pipe}}$  are negligible as compared to  $R_{\text{ins}}$  and  $R_{\text{air}}$   
 (b)  $R_{\text{pipe}}$  and  $R_{\text{air}}$  are negligible as compared to  $R_{\text{ins}}$  and  $R_{\text{steam}}$   
 (c)  $R_{\text{steam}}$  and  $R_{\text{air}}$  are negligible as compared to  $R_{\text{pipe}}$  and  $R_{\text{ins}}$   
 (d) No quantitative data is provided, therefore no comparison is possible.

IES-57. Solar energy is absorbed by the wall of a building as shown in the above figure. Assuming that the ambient temperature inside and outside are equal and considering steady-state, the equivalent circuit will be as shown in (Symbols:  $R_{co} = R_{\text{convection, outside}}$   $R_{ci} = R_{\text{convection, inside}}$  and  $R_w = R_{\text{Wall}}$ )

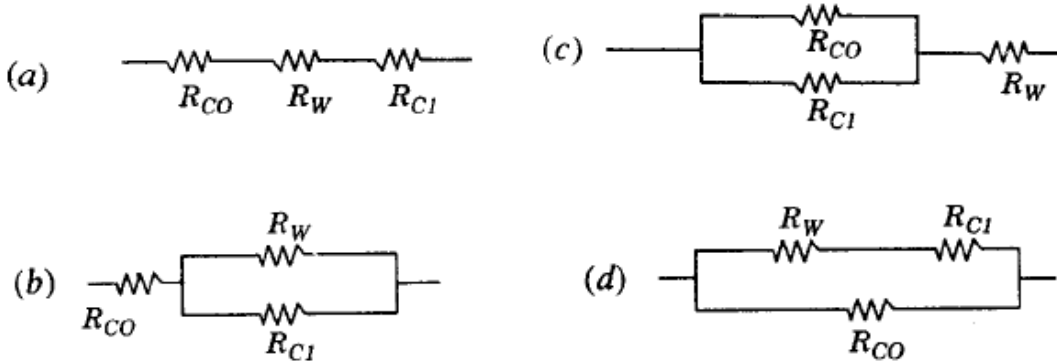
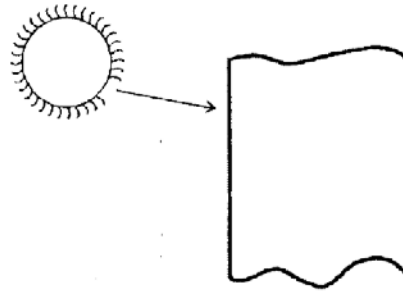

[IES-1998]

- IES-58. Which of the following would lead to a reduction in thermal resistance?
1. In conduction; reduction in the thickness of the material and an increase in the thermal conductivity. [IES-1994]
  2. In convection, stirring of the fluid and cleaning the heating surface.
  3. In radiation, increasing the temperature and reducing the emissivity.

Codes: (a) 1, 2 and 3      (b) 1 and 2      (c) 1 and 3      (d) 2 and 3

### Radiation Shields

IES-59. Two long parallel surfaces, each of emissivity 0.7 are maintained at different temperatures and accordingly have radiation exchange between them. It is desired to reduce 75% of this radiant heat transfer by inserting thin parallel shields of equal emissivity (0.7) on both sides. What would be the number of shields? [IES-1992; 2004]

- (a) 1                      (b) 2                      (c) 3                      (d) 4

IES-60. Two long parallel plates of same emissivity 0.5 are maintained at different temperatures and have radiation heat exchange between them. The radiation shield of emissivity 0.25 placed in the middle will reduce radiation heat exchange to: [IES-2002]

- (a)  $\frac{1}{2}$                       (b)  $\frac{1}{4}$                       (c)  $\frac{3}{10}$                       (d)  $\frac{3}{5}$

## Answers with Explanation (Objective)

## Previous 20-Years GATE Answers

GATE-1. Ans. (b)

GATE-2. Ans. (a)

GATE-3. Ans. (d)

GATE-4. Ans. (d)

GATE-5. Ans. (b) It is shape factor  $= 1 - \frac{A_1}{A_2} = 1 - \frac{\pi D_1 L}{\pi D_2 L} = 1 - \frac{1}{2} = 0.5$

GATE-6. Ans. (a)

GATE-7. Ans. (d) Principal of conservation gives

$$F_{1-1} + F_{1-2} + F_{1-3} = 1$$

$$F_{1-1} = 0, \text{ flat surface cannot see itself}$$

$$\therefore 0 + F_{1-2} + 0.17 = 1 \quad \text{or } F_{1-2} = 0.83$$

GATE-8. Ans. (a)  $F_{12} = F_{21} = 1 - \sin\left(\frac{\alpha}{2}\right) = 1 - \sin 10 = 0.83$

GATE-9. Ans. (c)  $F_{2-2} = 0$ ;  $F_{2-1} = 1$  and

$$A_1 F_{1-2} = A_2 F_{2-1} \quad \text{or } F_{1-2} = \frac{A_2}{A_1}$$

and  $F_{1-1} + F_{1-2} = 1$  gives

$$F_{1-1} = 1 - F_{1-2} = 1 - \frac{A_2}{A_1}$$

$$= 1 - \frac{(\pi DL + 2 \times \pi D^2 / 4)}{4\pi r^2}$$

[and given  $D = L$ ]

$$F_{1-1} = 1 - \frac{1.5 \times 0.5^2}{4 \times 0.5^2} = 0.625$$

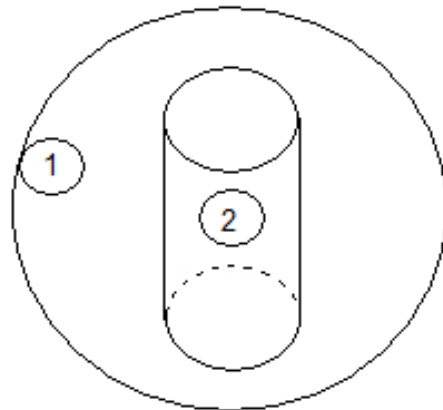

GATE-10. Ans. (b)  $f_{12} = \frac{1}{\frac{1}{\epsilon_1} + \frac{1}{\epsilon_2} - 1} = \frac{1}{\frac{1}{0.9} + \frac{1}{0.9} - 1} = 0.818$

$$Q = f_{12} \sigma (T_1^4 - T_2^4) = 0.818 \times 5.67 \times 10^{-8} (400^4 - 300^4) = 812 \text{ W}$$

GATE-11. Ans. (b) Given:  $A_1 = 2 \times 10 \text{ cm}^2 = 2 \times 10^{-3} \text{ m}^2$  and  $A_2 = 100 \text{ m}^2$

$$T_1 = 800 \text{ K}$$

$$T_2 = 300 \text{ K}$$

$$\epsilon_1 = 0.6$$

$$\epsilon_2 = 0.3$$

$$\text{Interchange factor } (f_{1-2}) = \frac{1}{\frac{1}{\epsilon_1} + \frac{A_1}{A_2} \left( \frac{1}{\epsilon_2} - 1 \right)} = \frac{1}{\frac{1}{0.6} + \frac{2 \times 10^{-3}}{100} \left( \frac{1}{0.3} - 1 \right)} = 0.6$$

$$Q_{net} = f_{1-2} \sigma A_1 (T_1^4 - T_2^4) = 0.6 \times 5.67 \times 10^{-8} \times 2 \times 10^{-3} (800^4 - 300^4) \text{ W} = 27.32 \text{ W}$$

## Previous 20-Years IES Answers

IES-1. Ans. (c)

IES-2. Ans. (a)

IES-3. Ans. (d) Wall and furnace has different temperature.

IES-4. Ans. (d) All parameters are responsible for loss of heat from a hot pipe surface.

IES-5. Ans. (c) In boiler, the energy from flame is transmitted mainly by radiation to water wall and radiant super heater.

IES-6. Ans. (c) Maximum efficiency of solar engine =  $\frac{T_1 - T_2}{T_1}$

$$= \frac{(500 + 273) - (27 + 273)}{500 + 273} = \frac{473}{773} \left( = \frac{W_1}{Q_1} \right) \text{ say,}$$

where,  $W$  is the work output for  $Q_1$  heat input.

Maximum efficiency of second engine =  $\frac{(273 + 80) - (273 + 27)}{273 + 80} = \frac{53}{353} \left( = \frac{W_2}{Q_2} \right) \text{ say,}$

where,  $W_2$  is the work output of second engine for  $Q_2$  heat output.

Assuming same heat input for the two engines, we have

$$\therefore \frac{W_1}{W_2} = \frac{473/77333}{53/353} = 4$$

IES-7. Ans. (c)

IES-8. Ans. (c)

IES-9. Ans. (c)

IES-10. Ans. (a)

IES-11. Ans. (d)

IES-12. Ans. (d)

IES-13. Ans. (b)

IES-14. Ans. (c)  $E = \sigma AT^4$ ;  $\therefore \frac{E_A}{E_B} = \frac{4\pi r_A^2 T_A^4}{4\pi r_B^2 T_B^4} = \frac{1^2 \times 4000^4}{4^2 \times (2000)^4} = 1$

IES-15. Ans. (a)

IES-16. Ans. (d) Emissive power ( $E$ ) =  $\varepsilon\sigma T^4$  or  $\frac{E_1}{E_2} = \left(\frac{T_1}{T_2}\right)^4 = \left(\frac{300}{900}\right)^4 = \frac{1}{81}$

IES-17. Ans. (d) Irradiation on a small test surface placed inside a hollow black spherical chamber =  $\sigma T^4 = 5.67 \times 10^{-8} \times 600^4 = 7348 \text{ W/m}^2$

IES-18. Ans. (a) Rate of emission of radiative flux =  $\sigma T^4$

or  $7.35 \times 10^3 = 5.67 \times 10^{-8} \times T^4$  or  $T = 600 \text{ K}$

IES-19. Ans. (c)

IES-20. Ans. (b)

Heat transfer through solid	→	Fourier's law of heat conduction
Heat transfer from hot surface to surrounding fluid	→	Newton's law of cooling
Heat transfer in boiling liquid	→	Convection heat transfer
Heat transfer from one body to	→	Radiation heat

another transfer separated in space

IES-21. Ans. (a)

IES-22. Ans. (b)

IES-23. Ans. (b)

IES-24. Ans. (d) Total emissive power is defined as the total amount of radiation emitted by a body per unit time

$$\begin{aligned} \text{i.e. } E &= \int E_{\lambda} \lambda d\lambda = 0 \times 3 + 150 \times (12 - 3) + 300 \times (25 - 12) + 0[\alpha] \\ &= 150 \times 9 + 300 \times 13 = 1350 + 3900 = 5250 \text{ W/m}^2 \end{aligned}$$

IES-25. Ans. (c)

IES-26. Ans. (c)

IES-27. Ans. (b) As per Wien's law,  $\lambda_1 T_1 = \lambda_2 T_2$  or  $5800 \times 0.5 = \lambda_2 \times 573$

IES-28. Ans. (c)

IES-29. Ans. (c) We know that,  $I = \frac{E}{\pi}$

IES-30. Ans. (c)

IES-31. Ans. (c) All the emission from one plate will cross another plate. So Shape Factor in one.

IES-32. Ans. (b)  $A_1 F_{1-2} = A_2 F_{2-1}$

$$\text{or } F_{2-1} = \frac{A_1}{A_2} F_{1-2} = \frac{6}{4} \times 0.1 = 0.15$$

IES-33. Ans. (c)

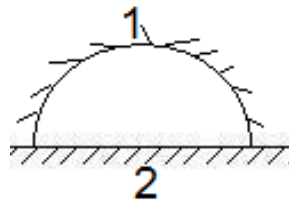

$$F_{2-1} + F_{2-2} = 1, \quad \because F_{2-2} = 0 \quad \text{or } F_{2-1} = 1$$

$$A_1 F_{1-2} = A F_{2-1}$$

$$\text{or } F_{1-2} = \frac{A_2}{A_1} F_{2-1} = \frac{\pi r^2 \times 1}{2\pi r^2} = \frac{1}{2}$$

$$F_{1-1} + F_{1-2} = 1 \quad \text{or } F_{1-1} = \frac{1}{2} = 0.5$$

IES-34. Ans. (b)  $F_{22} = 0; \therefore F_{21} = 1$

$$A_1 F_{12} = A_2 F_{21} \quad \text{or } F_{12} = \frac{A_2}{A_1} = \frac{\pi r^2}{2\pi r^2} = \frac{1}{2}$$

IES-35. Ans. (d)  $F_{11} + F_{12} = 1; \quad \because F_{11} = 0$

$$0 + F_{12} = 1 \quad \Rightarrow F_{12} = 1$$

$$A_1 F_{12} = A_2 F_{21} \quad \Rightarrow F_{21} = \frac{A_1}{A_2} = \frac{4\pi \left(\frac{D}{2}\right)^2}{6D^2} = \frac{\pi}{6}$$

IES-36. Ans. (c)

IES-37. Ans. (b)

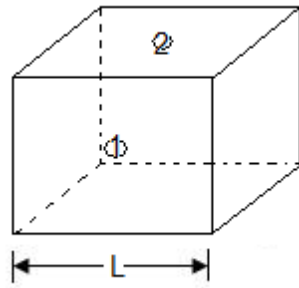

Shape factor  $F_{12}$  means part of radiation body 1 radiating and body 2 absorbing

$$F_{11} + F_{12} = 1$$

$$\text{or } 0 + F_{12} = 1$$

$$\text{then } A_1 F_{12} = A_2 F_{21} \text{ or } A_2 F_{21}$$

$$\text{or } F_{21} = \frac{A_1}{A_2} \times F_{12} = \frac{0.6}{6L^2} \times 1 = 0.004$$

$$\text{or } L = \sqrt{\frac{0.6}{6 \times 0.004}} = 5 \text{ m}$$

IES-38. Ans. (d) Shape factor  $F_{22} = 1 - \frac{A_1}{A_2} = 1 - \frac{2rl}{\pi r l} = 0.36$

IES-39. Ans. (c)  $F_{11} + F_{12} = 1$  as  $F_{11} = 0$  or  $F_{12} = 1$

$$A_1 F_{12} = A_2 F_{21} \text{ or } F_{21} = \frac{A_1 F_{12}}{A_2} = \frac{1}{3} \text{ or } F_{22} = \frac{2}{3}$$

IES-40. Ans. (b)

IES-41. Ans. (d)

IES-42. Ans. (b)  $F_{2-2} = 0, \therefore F_{2-1} = 1$

$$A_1 F_{1-2} = A_2 F_{2-1} \text{ or } F_{12} = \frac{A_2}{A_1} = \frac{\pi d^2 / 4}{\frac{\pi d^2}{4} + \pi D h} = \frac{d}{d + 4h}$$

IES-43. Ans. (b)  $F_{14} = 1 - 0.1 - 0.4 - 0.25 = 0.25$

$$A_1 F_{14} = A_4 F_{41} \text{ or } F_{41} = \frac{A_1 F_{14}}{A_4} = \frac{4}{2} \times 0.25 = 0.5$$

IES-44. Ans. (d)

IES-45. Ans. (c)

IES-46. Ans. (b)

IES-47. Ans. (c) When body 1 is completely enclosed by body 2, body 1 is large.

$$\therefore \epsilon \text{ is given by } \frac{1}{\frac{1}{\epsilon_1} + \frac{A_1}{A_2} \left( \frac{1}{\epsilon_2} - 1 \right)}$$

$$\epsilon = \epsilon_1$$

$$\therefore q_{1-2} = A_1 \epsilon_1 \sigma (T_1^4 - T_2^4)$$

IES-48. Ans. (b)

IES-49. Ans. (d)

IES-50. Ans. (b) Interchange factor ( $f_{12}$ )

$$= \frac{1}{\frac{1}{\epsilon_1} + \frac{1}{\epsilon_2} - 1} = \frac{1}{\frac{2}{0.9} - 1} = 0.8182$$

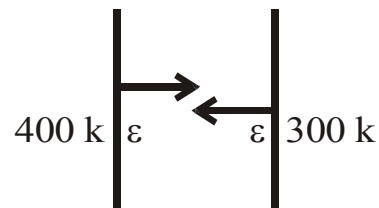

IES-51. Ans. (b) Heat transfer  $Q = \sigma F_e F_A (T_1^4 - T_2^4) W / m^2; \sigma = 5.67 \times 10^{-8} W/m^2 K^4$

$$F_e = \text{effective emissivity coefficient} = \frac{1}{\frac{1}{\varepsilon_1} + \frac{1}{\varepsilon_2} - 1} = \frac{1}{\frac{1}{0.8} + \frac{1}{0.6} - 1} = \frac{12}{23}$$

Shape factor  $F_A = 1$

$$Q = 5.67 \times 10^{-8} \times 1 \times \frac{12}{23} (800^4 - 500^4) = 1026 \text{ W/m}^2 = 10.26 \text{ kW/m}^2$$

**IES-52. Ans. (d)**

**IES-53. Ans. (c)**  $J = \varepsilon E_b + (1 - \varepsilon)G$

$$12 = \varepsilon \times 10 + (1 - \varepsilon) \times 20 \quad \text{or} \quad \varepsilon = 0.8$$

**IES-54. Ans. (b)**

**IES-55. Ans. (c)**

**IES-56. Ans. (a)** The resistance due to steam film and pipe material are negligible in comparison to resistance of insulation material and resistance due to air film.

**IES-57. Ans. (a)** All resistances are in series.

**IES-58. Ans. (b)** 1. In conduction, heat resistance =  $\Delta x/kA$

Thus reduction in thickness and increase in area result in reduction of thermal resistance.

2. Stirring of fluid and cleaning the heating surface increases value of  $h$ , and thus reduces thermal resistance.

3. In radiation, heat flow increases with increase in temperature and reduces with reduction in emissivity. Thus thermal resistance does not decrease.

Thus 1 and 2 are correct.

$$\text{IES-59. Ans. (c)} \quad \frac{Q_{\text{with shield}}}{Q_{\text{without shield}}} = \frac{1}{n+1} \quad \text{or} \quad 0.25 = \frac{1}{n+1} \quad \text{or} \quad n = 3$$

**IES-60. Ans. (c)**

10.

Mass Transfer

Theory at a Glance (For IES, GATE, PSU)

**What is Mass Transfer?**

“Mass transfer specifically refers to the relative motion of species in a mixture due to concentration gradients.”

**Analogy between Heat and Mass Transfer**

Since the principles of mass transfer are very similar to those of heat transfer, the analogy between heat and mass transfer will be used throughout this module.

**Mass transfer through Diffusion**

**Conduction**

$$q'' = -k \frac{dT}{dy} \left[ \frac{J}{m^2s} \right]$$

(Fourier's law)

**Mass Diffusion**

$$j_A'' = -\rho D_{AB} \frac{d\xi_A}{dy} \left[ \frac{kg}{m^2s} \right]$$

(Fick's law)

$\rho$  Is the density of the gas mixture and  $D_{AB}$  is the diffusion coefficient

$\xi_A = \rho_A / \rho$  Is the mass concentration of component A.

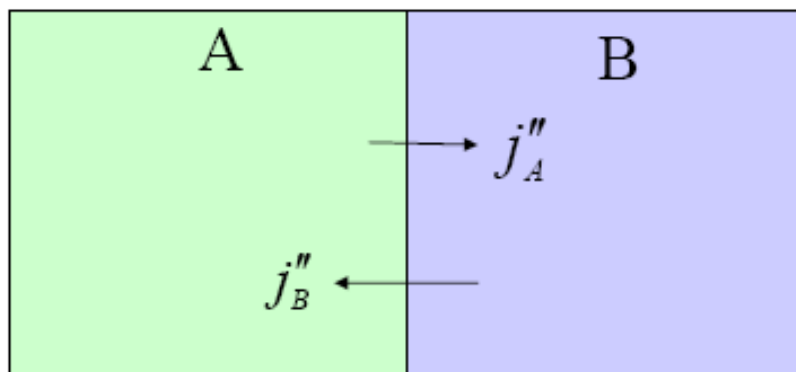

The sum of all diffusion fluxes must be zero:  $\sum j_i'' = 0$

$$\begin{aligned} \xi_A + \xi_B &= 1 \\ \frac{d}{dy} \xi_A &= -\frac{d}{dy} \xi_B \\ D_{BA} &= D_{AB} = D \end{aligned}$$

**Heat and Mass Diffusion: Analogy**

- Consider unsteady diffusive transfer through a layer



Heat conduction, unsteady, semi-infinite plate

$$\rho c \frac{\partial T}{\partial t} = \frac{\partial}{\partial x} \left( k \frac{\partial T}{\partial x} \right)$$

$$\frac{\partial T}{\partial t} = \frac{k}{\rho c} \frac{\partial^2 T}{\partial x^2} = \alpha \frac{\partial^2 T}{\partial x^2}$$

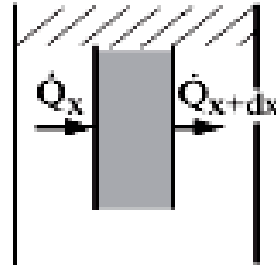

Similarity transformation: PDE → ODE

$$\frac{d^2 T}{dy^2} + 2\eta \frac{dT}{d\eta} = 0, \quad \eta = \frac{x}{\sqrt{4\alpha t}}$$

Solution: 
$$\frac{T - T_0}{T_u - T} = 1 - \operatorname{erf} \left( \frac{x}{\sqrt{4\alpha t}} \right)$$

Temperature field

Heat flux  $q''|_{x=0} = k \frac{dT}{dx} \Big|_{x=0} = \frac{k}{\sqrt{\pi\alpha t}} (T_u - T_0) = \sqrt{\frac{k c \rho}{\pi t}} (T_u - T)$

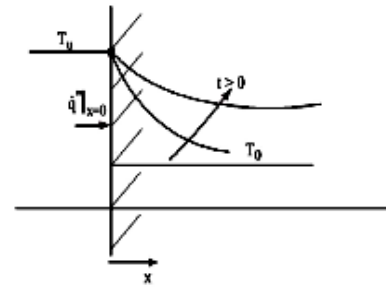

Diffusion of a gas component, which is brought in contact with another gas layer at time  $t=0$  differential equation:

$$\frac{\partial \rho_i}{\partial t} = \rho D \frac{\partial^2 \xi_i}{\partial x^2}$$

$$\frac{\partial \xi_i}{\partial t} = D \frac{\partial^2 \xi_i}{\partial x^2}$$

Initial and boundary conditions:

$$\xi_i(t=0, x) = \xi_{i.o}$$

$$\xi_i(t > 0, x=0) = \xi_{i.u}$$

$$\xi_i(t > 0, x=\infty) = \xi_{i.o}$$

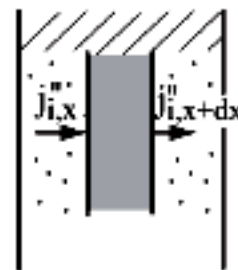

Transient diffusion

Solution: 
$$\frac{\xi_i - \xi_{i.o}}{\xi_{i.u} - \xi_{i.o}} = 1 - \operatorname{erf} \left( \frac{x}{\sqrt{4Dt}} \right)$$

Concentration field

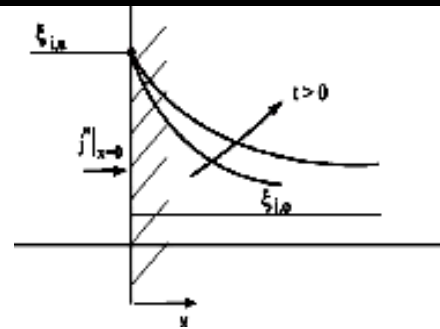

Diffusive mass flux  $j''_i \Big|_{x=0} = \frac{\rho D}{\sqrt{\pi D t}} (\xi_{i.Ph} - \xi_{i.o})$

### Diffusive Mass Transfer on a Surface (Mass convection)

Fick's Law, diffusive mass flow rate:

$$j''_A = -\rho D \frac{\partial \xi}{\partial y} \Big|_{y=0} = -\rho D \frac{\xi_\infty - \xi_w}{L} \frac{\partial \xi^*}{\partial y^*} \Big|_{y^*=0}$$

Mass transfer coefficient  $h_{mass} \left[ \frac{kg}{m^2 s} \right]$

$$j''_A = h_{mass} (\xi_w - \xi_\infty)$$

Dimensionless mass transfer number, the Sherwood number Sh

$$\frac{h_{mass} L}{\rho D} Sh = \frac{\partial \xi^*}{\partial y^*} \Big|_{y^*=0} = f(Re, Sc)$$

$$Sh = C Re^m Sc^n$$

**Note:** Compare with energy equation And Nusselt Number: The constants *C* and the exponents' *m* and *n* of both relationships must be equal for comparable boundary conditions.

Dimensionless number to represent the relative magnitudes of heat and mass diffusion in the thermal and concentration boundary layers

Lewis Number:  $Le = \frac{Sc}{Pr} = \frac{\alpha}{D} = \frac{\text{Thermal diffusivity}}{\text{Mass diffusivity}}$

### Analogy between heat and mass transfer

Comparing the correlation for the heat and mass transfer

$$\frac{Sh}{Nu} = \left( \frac{Sc}{Pr} \right)^n$$

Hence,  $\frac{h_{mass}}{h / c_p} = \left( \frac{Sc}{Pr} \right)^{n-1}$

For gases,  $Pr \approx Sc$ , hence:  $\frac{h_{mass}}{h / c_p} = 1$  **Lewis relation**

### NUMBERS (Mechanical Engineering)

1. **Boiling Number**,  $(B_0) = \frac{h \Delta T}{G h_{fg}}$  ;  $G = \text{mass velocity} = \rho v$

2. **Condensation Number**,  $(C_0) = h_0 \left[ \frac{\mu_f^2}{K_f^3 \rho_f (\rho_f - \rho_g) g} \right]^{\frac{1}{3}}$

3. **Nusselt Number**  $(N_u) = \frac{hL}{K} = \frac{\text{convective heat transfer rate}}{\text{heat conducted under temperature gradient } \frac{\Delta T}{L}}$

4. **Reynolds Number**  $(R_e) = \frac{\rho V D}{\mu} = \frac{\text{Inertia force}}{\text{viscous force}}$

5. **Prandtl Number**  $(P_r) = \frac{C_p \mu}{K} = \frac{\text{Kinematic viscosity}(\nu)}{\text{Thermal diffusivity}(\alpha)}$

6. **Grashof Number**  $(G_r) = \frac{\rho^2 \beta g \Delta T L^3}{\mu^2} = \frac{\text{Inertia force} \times \text{Boyancy force}}{(\text{viscous force})^2}$

7. **Lewis Number**  $(L_e) = \frac{f_g}{C_p K_w} = \frac{k}{\rho C_p D} = \left( \frac{\alpha}{D} \right)^{1-C}$   
 $= \left( \frac{\alpha}{D} \right)^{2/3}$  For forced convection of air.  
 $= \left( \frac{\alpha}{D} \right)^{0.48}$  For natural convection of air.

8. **Schmidt Number**  $(S_c) = \frac{\mu}{\rho D} = \frac{\text{Dynamic viscosity}}{\text{mass diffusivity}}$

9. **Stanton Number**  $(S_t) = \frac{h}{\rho V C_p} = \frac{N_u}{R_e P_r} = \frac{\text{friction factor}}{2} = \frac{\text{Wall heat transfer rate}}{\text{Mass heat flow rate}}$

10. **Sherwood Number**  $(Sh) = \frac{K_w L}{\rho D} = \frac{h_m x}{D}$  [ $h_m = \text{mass transfer co-efficient}$ ]

11. **Peclet Number**  $(P_e) = \frac{L v}{\alpha} = \frac{\text{mass heat flow rate} (\rho v C_p)}{\text{Heat flow rate by conduction under a unit temp. gradiet and through a thickness L.}}$

$$P_e = R_e \times P_r$$

12. **Graetz Number**  $(G_r) = \frac{m c_p}{L_k} = \frac{\text{heat capacity of the fluid flowing through the pipe per unit length of the pipe}}{\text{Conductivity of the pipe}}$   
 $= P_e \left( \frac{\pi d}{4} \right)$

13. **Cetane Number** = the cetane number of a fuel is the percentage by volume of cetane in a mixture of cetane and  $\alpha$  - methylnaphthalene ( $C_{10}H_7CH_3$ ) that has the same performance in the standard test engine as that of the fuel.

$$\text{Cetane Number} = \frac{104 - \text{Octane Number}}{2.75}$$

14. **Octane Number:** The octane number of a fuel is the percentage by volume iso-octane in a mixture of iso-octane and n-heptanes that has the same detonation under the same conditions as the fuel under test.

$$\text{Octane Number} = 100 + \frac{\text{PN}-100}{3} \text{ for using additives.}$$

15. **Performance Number (PN):**

$$\begin{aligned} &= \frac{\text{Knock limited indicated mean effective pressure of the test fuel}}{\text{Knock limited indicated mean effective pressure of the iso - octane}} \\ &= \frac{\text{KLIMEP of test fule}}{\text{KLIMEP of iso - octane}} \end{aligned}$$

16. **Research octane Number (RON)**  $\Rightarrow$  when test under mild operating condition i.e. low engine speed and low mixture temperature.

17. **Motor Octane Number (MON)**  $\Rightarrow$  when test carried out under more severe operating conditions (High engine speed and higher mixture temperature)  
 $\rightarrow \text{ROM} > \text{MON}$

18. **Froude Number** ( $F_e$ ) =  $\frac{V}{\sqrt{Lg}} = \sqrt{\frac{F_i}{F_g}}$ ;  $F_g$  = gravity force ( $\rho ALg$ )

19. **Euler Number** ( $E_u$ ) =  $\frac{V}{\sqrt{P/\rho}} = \sqrt{\frac{F_i}{F_p}}$ ;  $F_p$  = pressure force = PA

20. **Weber Number** ( $W_e$ ) =  $\frac{V}{\sigma/\rho L} = \frac{F_i}{F_s}$ ;  $F_s$  = surface tension force =  $\sigma L$

21. **Mach Number** (M) =  $\frac{V}{\sqrt{K/\rho}} = \sqrt{\frac{F_i}{F_e}}$ ;  $F_e$  = Elastic force =  $KL^2$

22. **Bearing characteristic Number** =  $\frac{\mu N}{P}$

23. **Summer feld Number** =  $\frac{\mu N_s}{p} \left(\frac{r}{c}\right)^2$

24. **Biot Number** ( $B_i$ ) =  $\frac{h\delta}{K} = \frac{\text{Internal ressistance of the fin material} \left(\frac{\delta}{K}\right)}{\text{External resistance of the fluid on fin surface} \left(\frac{1}{h}\right)}$

It is dimensionless and is similar to Nusselt number. However, there is an important difference, the thermal conductivity in Biot number refers to the conduction body where in Nusselt Number, and it is the conductivity of convecting fluid.

25. **Fourier Number** =  $\frac{\alpha t}{\delta^2}$

26. **Lorenz Number** =  $\sqrt{\frac{K}{K_e T_\omega}}$

K = Thermal conductivity

$K_e$  = electrical conductivity

$T_\omega$  = wire wall temperature.

<b>Number</b>	<b>Application</b>
1. Grashof Number	Natural convection of ideal fluid.
2. Stanton Number	Forced convection.
3. Peclet Number	Forced convection for small prandtl number.
4. Schmidt Number, Sherwood	Mass transfer.
5. Biot Number and Fourier Number	Transient conduction.

## OBJECTIVE QUESTIONS (GATE, IES, IAS)

## Previous 20-Years IES Questions

**Modes of Mass Transfer**

**IES-1. Consider the following statements: [IES-2010]**

1. Mass transfer refers to mass in transit due to a species concentration gradient in a mixture.
2. Must have a mixture of two or more species for mass transfer to occur.
3. The species concentration gradient is the driving potential for mass transfer.
4. Mass transfer by diffusion is analogous to heat transfer by conduction.

**Which of the above statements are correct ?**

- |                     |                     |
|---------------------|---------------------|
| (a) 1, 2 and 3 only | (b) 1, 2 and 4 only |
| (c) 2, 3 and 4 only | (d) 1, 2, 3 and 4   |

**IES-2. If heat and mass transfer take place simultaneously, the ratio of heat transfer coefficient to the mass transfer coefficient is a function of the ratio of: [IES-2000]**

- |                                  |                                 |
|----------------------------------|---------------------------------|
| (a) Schmidt and Reynolds numbers | (b) Schmidt and Prandtl numbers |
| (c) Nusselt and Lewis numbers    | (d) Reynolds and Lewis numbers  |

**IES-3. In case of liquids, what is the binary diffusion coefficient proportional to? [IES-2006]**

- |                   |                      |
|-------------------|----------------------|
| (a) Pressure only | (b) Temperature only |
| (c) Volume only   | (d) All the above    |

**IES-4. In a mass transfer process of diffusion of hot smoke in cold air in a power plant, the temperature profile and the concentration profile will become identical when: [IES-2005]**

- |                     |                     |
|---------------------|---------------------|
| (a) Prandtl No. = 1 | (b) Nusselt No. = 1 |
| (c) Lewis No. = 1   | (d) Schmidt No. = 1 |

IES-5. Given that: [IES-1997]

$N_u$  = Nusselt number

$Re$  = Reynolds number

$Pr$  = Prandtl number

$Sh$  = Sherwood number

$Sc$  = Schmidt number

$Gr$  = Grashoff number

The functional relationship for free convective mass transfer is given as:

$$(a) N_u = f(G_r, Pr) \quad (b) S_h = f(S_c, Gr) \quad (c) N_u = f(Re, Pr) \quad (d) S_h = f(Re, Sc)$$

IES-6. Schmidt number is ratio of which of the following? [IES-2008]

- (a) Product of mass transfer coefficient and diameter to diffusivity of fluid
- (b) Kinematic viscosity to thermal diffusivity of fluid
- (c) Kinematic viscosity to diffusion coefficient of fluid
- (d) Thermal diffusivity to diffusion coefficient of fluid

## Answers with Explanation (Objective)

## Previous 20-Years IES Answers

IES-1. Ans. (d)

IES-2. Ans. (b)  $Nu_x = (const.)_1 \times (Re)^{0.8} \times (Pr)^{1/3}$

$$Sh_x = (const.)_2 \times (Re)^{0.8} \times (Se)^{1/3}$$

$$\therefore \frac{h_x}{h_{xm}} = (const.)_3 \left( \frac{Pr}{Se} \right)^{1/3}$$

IES-3. Ans. (b)

IES-4. Ans. (c)

IES-5. Ans. (b)

IES-6. Ans. (c) Schmidt number

$$Sc = \frac{\mu}{\rho D} = \frac{\nu}{D} = \frac{\text{Momentum diffusivity}}{\text{Mass diffusivity}}$$